

CM Series 633 wide range trolley

Simple, rugged, built for trouble-free service and ease of operation across a wide range of beam applications. Series 633 features:

- Rugged steel side plates formed to include bumpers and trolley guards
- Frames connected by steel equalizer pin, secured by two nuts on each side
- Universal tread flanged trackwheels equipped with shielded ball bearings
- Easy rolling on American standard shapes, wide flange shapes or patented rail
- Hardened wheels and axles for added strength and durability
- Spacer washers can be shifted inside or outside for easy adjustment to wide range of beams
- To be used with hook suspended hoist
- Suspension plate for easy attachment is standard
- Bearings prepacked with lifetime lubricant
- One-year warranty
- Imported

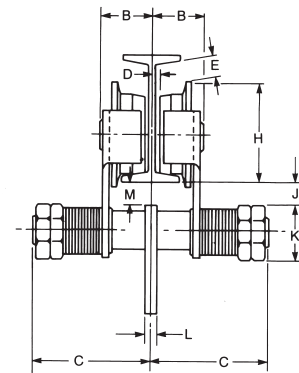
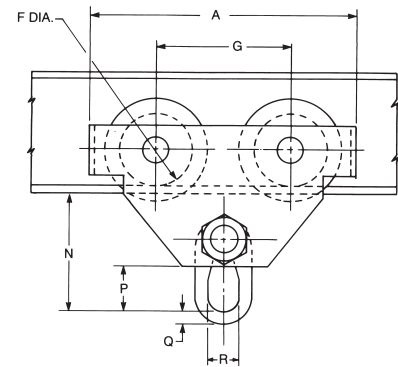

Clearance dimensions (in.)

Dimension	Rated capacity* (tons)				
	1/2	1	2	3	5
Min. radius curve (in.)	35	35	59	71	94
A	8 1/2	10 13/16	12 7/32	14 13/16	18 1/8
B**	2 5/32	2 13/32	2 11/16	3 1/16	3 21/32
C	5 1/16	6 9/16	6 25/32	7 13/32	8
D**	1/16	7/16	13/32	1/2	9/16
E**	-1/4	11/32	25/32	17/16	23/16
F	2 9/32	3 15/32	3 15/16	5 1/8	6 1/8
G	4	4 7/8	5 1/2	6 9/16	7 7/8
H**	3	4 11/32	4 29/32	6 1/8	7 9/32
J**	1 1/32	1 1/32	25/32	13/16	2 1/8
K	1 3/4	2 3/32	2 1/2	3 13/32	3 13/32
L	1/2	1/2	5/8	5/8	13/16
M**	15/16	3 1/32	5/16	15/16	1 7/16
N**	4 3/32	5 1/16	5 13/16	7 7/16	9 15/16
P	1 7/32	1 3/4	2 5/32	2 9/16	3 23/32
Q	1 9/32	1 9/32	1 3/16	1 3/8	1 25/32
R	3 1/32	1 5/32	1 5/8	1 31/32	2 9/16

**Dimensions given are for minimum S-beam and will vary with larger beams.

Specifications

Rated capacity* (tons)	Product code	Adj. for standard S-beams			Net weight (lbs.)	Shipping weight (lbs.)
		Depth of beam (in.)	Flange width (in.)	Tread diameter (in.)		
1/2	3302	3-15	2 1/2-5 5/8	2 9/32	15	17
1	3304	5-24	3-8	3 15/32	34	36
2	3306	6-24	3 5/8-8	3 15/16	50	53
3	3307	8-24	4-8	5 1/8	95	100
5	3309	10-24	4 5/8-8	6 1/8	172	175