

Cyclone hand chain hoist

One of the most popular and reliable hoists ever designed.

- Most interchangeability of parts in the industry
- Standard Load Limiter for simple, automatic overload protection
- Enclosed contoured Weston-type automatic brake for positive load control
- High-efficiency spur gearing for greater lift with minimum effort
- Rugged Hoist alloy chain for added strength and durability
- Fully machined, forged liftwheel pockets for easier lifting and smooth free chaining
- High-strength aluminum alloy castings in frame and covers
- Inspected over 75 times to meet or exceed HMI and ASME/ANSI performance and safety standards
- Standard hand chain drop is 2 feet less than lift, (example: 8 foot lift hoist has 6 foot hand chain drop)
- Lifetime warranty
- Metric rated
- Made in U.S.A.



Options Include:

- Fabric chain bags
- Metal chain containers
- Zinc-plated load and hand chain
- Unwelded hand chain
- Latchlok hooks
- Bronze hooks
- Bullard hooks
- Eye-type suspension

* WARNING

Overloading and improper use can result in injury.

To avoid injury:

- Do not exceed working load limit, load rating capacity
- Do not use to lift people or loads over people.
- use only alloy chain for overhead lifting.
- Read and follow all instructions.

The Cyclone combines superior engineering, efficiency and durability. Available in a variety of capacities from 1/4 ton to 10 tons.

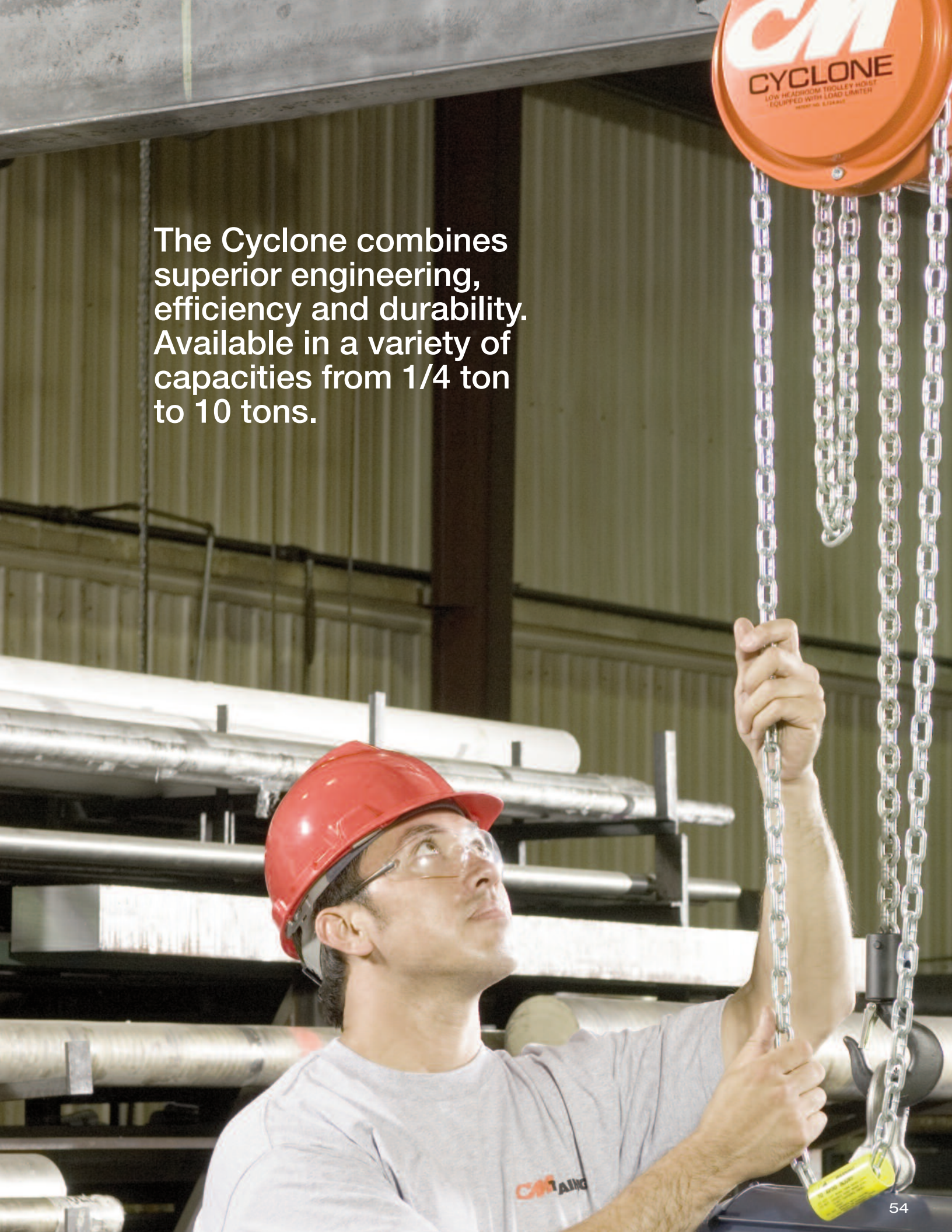

Cyclone hand chain hoist

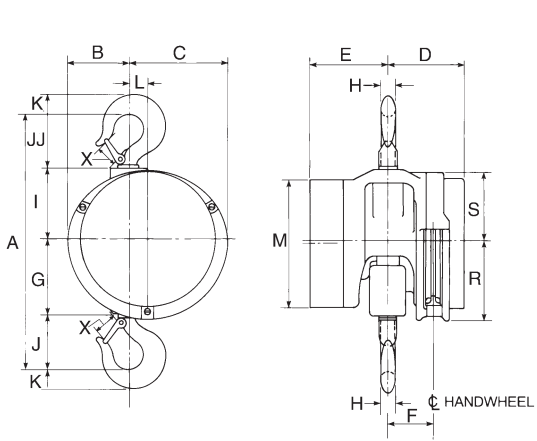

1/4 - 2 ton

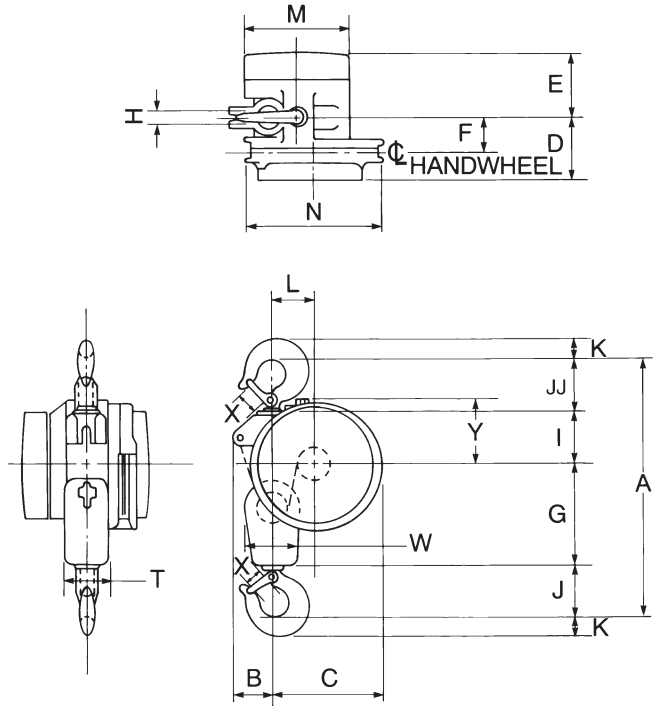

3 - 4 ton

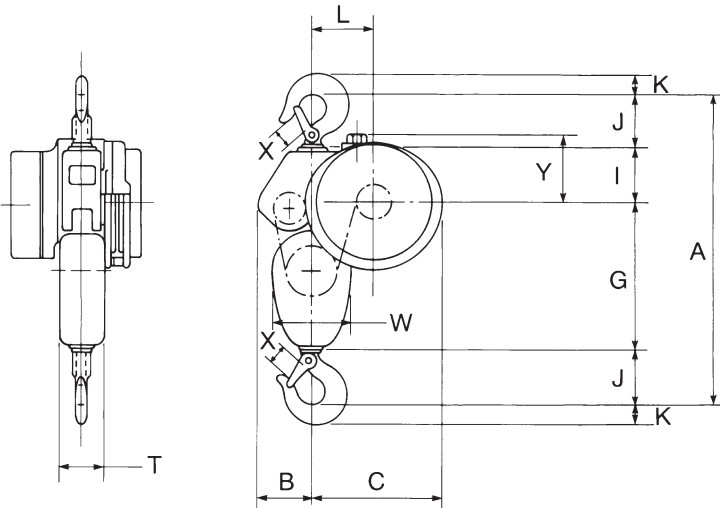
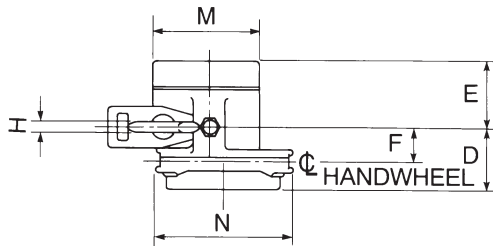

5 - 6 ton

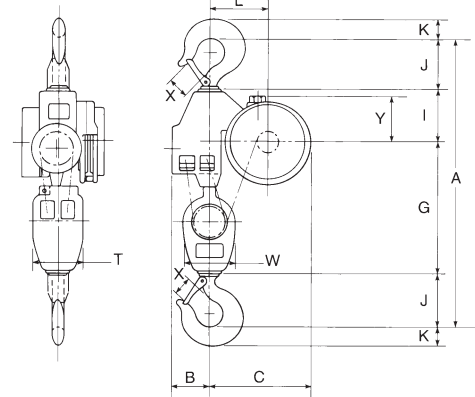
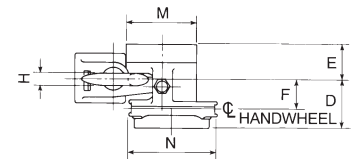

8 - 10 ton

Cyclone hand chain hoist-Specifications

Specifications

Rated capacity* (tons)	Product code	Standard lift† (ft.)	Reeving	Minimum distance between hooks (in.)	Chain overhauled to lift load one foot (ft.)	Chain pull to lift full load (lbs.)	Shipping weight (lbs.)
1/4	4621	8	1	12 ⁷ / ₈	22 ¹ / ₂	23	37
1/2	4622	8	1	12 ⁷ / ₈	22 ¹ / ₂	46	37
1	4624	8	1	14	30	69	40
1 1/2	4625	8	1	17 ⁵ / ₁₆	40 ¹ / ₂	80	65
2	4626	8	1	17 ⁵ / ₁₆	52	83	64
3	4627	8	2	21 ¹ / ₂	81	85	96
4	4628	8	2	21 ¹ / ₂	104	88	96
5	4629	8	3	24 ¹ / ₄	156	75	128
6	4630	8	3	25 ¹ / ₄	156	90	132
8	4631	8	4	34 ¹ / ₂	208	89	235
10	4632	8	5	35 ¹ / ₂	260	95	249

† Can be supplied with longer lifts

Clearance dimensions (in.)

Dimension	Rated capacity* (tons)								
	1/4	1/2	1	1 1/2 & 2	3 & 4	5	6	8	10
A	12 ⁷ / ₈	12 ⁷ / ₈	14	17 ⁵ / ₁₆	21 ¹ / ₂	24 ¹ / ₄	25 ¹ / ₄	34 ¹ / ₂	35 ¹ / ₂
B	3 ¹ / ₁₆	3 ¹ / ₁₆	3 ¹ / ₁₆	4 ³ / ₁₆	3 ⁵ / ₁₆	4 ³ / ₁₆	4 ³ / ₁₆	4 ³ / ₄	4 ³ / ₄
C	7 ³ / ₁₆	7 ³ / ₁₆	7 ³ / ₁₆	6 ¹ / ₁₆	8 ¹⁵ / ₁₆	10 ⁵ / ₁₆	10 ⁵ / ₁₆	12 ³ / ₄	12 ³ / ₄
D	4 ¹ / ₈	4 ¹ / ₈	4 ¹ / ₈	5 ¹ / ₁₆	5 ¹ / ₁₆	4 ⁷ / ₈	4 ⁷ / ₈	5 ¹³ / ₁₆	5 ¹³ / ₁₆
E	3 ¹ / ₄	3 ¹ / ₄	3 ¹ / ₄	4 ¹³ / ₁₆	4 ¹³ / ₁₆	5	5	4 ¹ / ₁₆	4 ¹ / ₁₆
F	2 ¹ / ₁₆	2 ¹ / ₁₆	2 ¹ / ₁₆	3 ¹ / ₈	3	2 ¹⁵ / ₁₆	2 ¹⁵ / ₁₆	3 ³ / ₄	3 ³ / ₄
G	3 ⁷ / ₈	3 ⁷ / ₈	3 ³ / ₄	5 ³ / ₁₆	8 ¹ / ₄	11 ¹³ / ₁₆	11 ¹³ / ₁₆	17 ³ / ₁₆	17 ³ / ₁₆
H	1 ¹ / ₁₆	1 ¹ / ₁₆	1 ³ / ₁₆	1 ¹ / ₈	1 ¹ / ₄	1 ¹ / ₄	1 ³ / ₈	1 ¹ / ₁₆	1 ¹³ / ₁₆
I	3 ³ / ₄	3 ³ / ₄	3 ³ / ₄	4 ¹³ / ₁₆	4 ¹ / ₄	4 ³ / ₁₆	4 ³ / ₁₆	6 ¹ / ₁₆	6 ¹ / ₁₆
J	2 ⁵ / ₈	2 ⁵ / ₈	2 ¹⁵ / ₁₆	3 ⁵ / ₈	4 ¹ / ₈	4 ¹ / ₈	4 ⁵ / ₈	5 ⁵ / ₈	6 ¹ / ₈
JJ	2 ⁵ / ₈	2 ⁵ / ₈	3 ⁹ / ₁₆	3 ¹ / ₁₆	4 ⁷ / ₈	—	—	—	—
K	1 ⁵ / ₁₆	1 ⁵ / ₁₆	1 ¹ / ₈	1 ¹ / ₂	1 ¹ / ₁₆	1 ¹ / ₁₆	1 ⁷ / ₈	2 ¹ / ₄	2 ⁹ / ₁₆
L	1 ³ / ₄	1 ³ / ₄	1 ³ / ₄	1 ¹ / ₄	3 ¹ / ₂	4 ⁷ / ₈	4 ⁷ / ₈	7 ⁵ / ₁₆	7 ⁵ / ₁₆
M	7 ¹ / ₁₆	7 ¹ / ₁₆	7 ¹ / ₁₆	8 ⁵ / ₈	8 ⁵ / ₈	8 ⁵ / ₈	8 ⁵ / ₈	8 ⁵ / ₈	8 ⁵ / ₈
N	—	—	—	—	10 ⁷ / ₈	10 ⁷ / ₈	10 ⁷ / ₈	10 ⁷ / ₈	10 ⁷ / ₈
R	5 ⁷ / ₁₆	5 ⁷ / ₁₆	5 ⁷ / ₁₆	5 ⁷ / ₁₆	—	—	—	—	—
S	4 ¹ / ₁₆	4 ¹ / ₁₆	4 ¹ / ₁₆	4 ¹ / ₁₆	—	—	—	—	—
T	—	—	—	—	3 ⁷ / ₈	4	4	6 ³ / ₈	6 ³ / ₈
W	—	—	—	—	4 ¹ / ₂	6 ¹ / ₄	6 ¹ / ₄	6 ⁷ / ₁₆	6 ⁷ / ₁₆
X	1 ¹ / ₃₂	1 ¹ / ₃₂	1 ¹ / ₈	1 ⁵ / ₁₆	1 ⁵ / ₈	1 ⁵ / ₈	1 ³ / ₄	2 ¹ / ₁₆	2 ⁵ / ₁₆
Y	—	—	—	—	5 ¹ / ₈	5 ⁷ / ₈	5 ⁷ / ₈	5 ⁹ / ₁₆	5 ⁹ / ₁₆

*** ⚠ WARNING**

Overloading and improper use can result in injury.

To avoid injury:

- Do not exceed working load limit, load rating capacity
- Do not use to lift people or loads over people.
- Use only alloy chain for overhead lifting.
- Read and follow all instructions.

Distributed by Ergonomic Partners

Sales@ErgonomicPartners.com

www.ErgonomicPartners.com

Tel: 314-884-8884