

JDN AIR HOISTS MINI



Distributed by Ergonomic Partners
Sales@ErgonomicPartners.com
www.ErgonomicPartners.com
Tel: 314-884-8884

J·D·NEUHAUS
1745
engineered for extremes

JDN AIR HOISTS MINI



The mini series at a glance



Energy supply
(spiral hose)

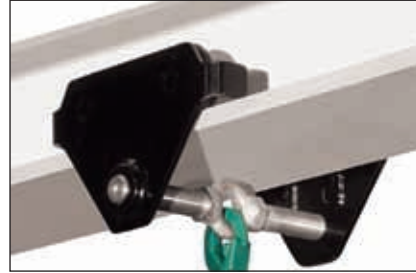

Manual trolleys

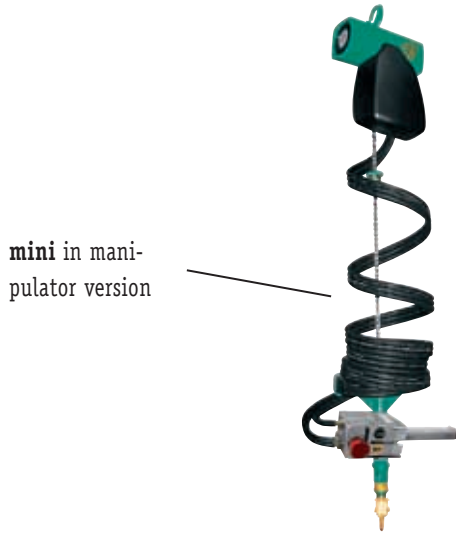

mini in mani-
pulator version



Galvanised chain
Corrosion Resistant

Sensitive control
Precise Positioning

Explosion classification
 II 3 GD IIA T4

Special grease for
oil-free operation





The JDN mini series for general duty

Carrying capacities: 275 Ibs, 500 Ibs, 1,100 Ibs, 2,200 Ibs
Air pressure: 85 PSI

The **mini** widens the range of applications as a handy, flexible and universally deployable hoist making it an ideal tool for a wide range of manufacturing and assembly applications.

mini Manipulator

With the **mini** manipulator loads can be lifted, lowered, manually traversed and positioned with only one hand. Further information on request.

Explosion Classification: II 3 GD IIA T4



mini 250



mini 250
in manual trolley



mini-
Manipulator

The advantages at a glance

- Price competitive alternative when compared to other types of powered hoists.
- Suitable for lube-free operation.
- Suitable for application in hazardous areas.
- Minimum components for ease of maintenance.
- Wear resistant motor braking system.
- Lightweight for easy handling.
- Also suitable for horizontal pulling.
- Extremely sensitive lever control with optional emergency stop, max. control length 20 ft.
- Available lifting heights: up to 26 ft.
- With chain box as standard.
- With manual trolley as option.

Technical Data

Type		mini 125	mini 250	mini 500	mini 1000
Capacity	lbs	275	550	1100	2160
	kg	125	250	500	980
Number of chain strands		1	1	1	1
Motor output	kW	0.4	0.4	1	1
Air pressure	PSI	85	85	85	85
	bar	6	6	6	6
Lifting speed without load ¹	ft/min	130	65	65	33
	m/min	40	20	20	10
Lifting speed at full load ¹	ft/min	49.5	26	33	16
	m/min	15	8	10	5
Lowering speed at full load	ft/min	99	52	59	33
	m/min	30	16	18	10
Lowering speed without load	ft/min	78.7	39.4	39.4	19.7
	m/min	24	12	12	6
Air consumption at full load – lifting	cfm	17.5	17.5	42.5	42.5
	m ³ /min	0.5	0.5	1.2	1.2
Air consumption at full load – lowering	cfm	24.7	24.7	56.5	56.5
	m ³ /min	0.7	0.7	1.6	1.6
Air connection		G 3/8	G 3/8	G 1/2	G 1/2
Hose dimension (Ø inside)	inch	3/8	3/8	1/2	1/2
	mm	9	9	13	13
Weight with 10 ft / 3 m lift	lbs	21	23.1	46.2	50.6
	kg	9.5	10.5	21	23
Chain dimension	mm	4 x 12	4 x 12	7 x 21	7 x 21
Weight of chain	lbs/ft	0.23	0.23	0.67	0.67
	kg/m	0.35	0.35	1.0	1.0
Height of lift	ft	10/16/26			
	m	3/5/8			
Length of control at standard lift	ft	6.5/13/20			
	m	2/4/6			
Noise level at full load ² – lifting	dB(A)	79	79	77	77
Noise level at full load ² – lowering	dB(A)	80	80	83	83

Group mechanism: M3 (1 Bm)

¹Lifting speed at 2 m length of control. Longer control hoses decrease the lifting speeds.

²Measured at 1 m distance acc. to DIN 45635 part 20

JDN AIR HOISTS MINI



Dimensions

Type		mini 125	mini 250	mini 500	mini 1000
A	inch mm	12.9 328	12.9 328	18.0 458	18.0 458
B	inch mm	9.1 232	9.1 232	12.4 316	12.4 316
C	inch mm	14.4 367	14.4 367	19.9 505	19.9 505
D	inch mm	3.6 92	3.6 92	4.8 122	4.8 122
E	inch mm	8.4 213	8.4 213	11.5 292	11.5 292
F	inch mm	4.3 109	4.3 109	5.8 148	5.8 148
G	inch mm	4.1 104	4.1 104	5.6 144	5.6 144
H	inch mm	7 177	7 177	9.2 234	9.2 234
J	inch mm	5.8 148	5.8 148	7.6 194	7.6 194
K	inch mm	3.3 83	3.3 83	4.7 119	4.7 119
L	inch mm	1.1 29	1.1 29	1.6 40	1.6 40
M	inch mm	0.7 19	0.7 19	1.1 28	1.1 28

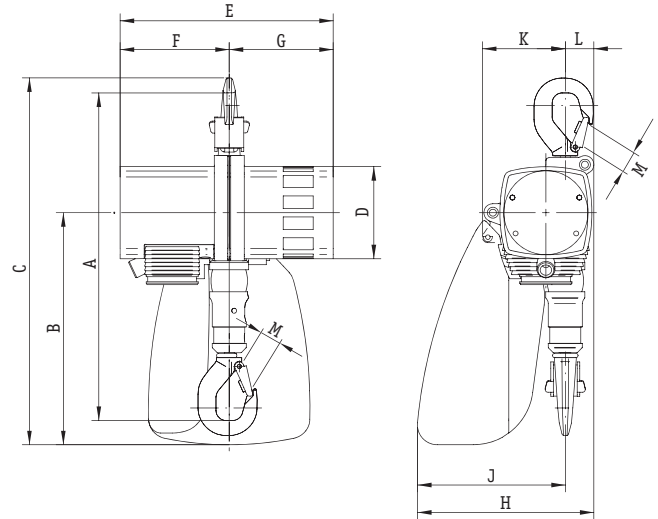

Manual Trolleys for JDN Air Hoists mini

Technical Data

Type		LN 250	LN 1000
Capacity	lbs	550	2200
	kg	250	1000
Beam flange width b	inch	2-8	2-8
	mm	50-220	58-220
max. flange thickness t	inch	1.3	1.2
	mm	34	30
min. curve radius	inch	35.4	39.4
	m	0.9	1.0
Weight	lbs	17	21
	kg	7.7	10.5

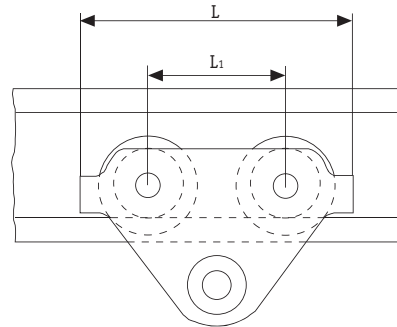

Dimensions

Type		LN 250	LN 1000
A	inch	3.1	3.1
	mm	79	79
D	inch	0.7	0.7
	mm	17	17
D ₁	inch	1	1.2
	mm	25	30
D ₂	inch	1.2	1.4
	mm	30	35
H ₁	inch	1.2	1
	mm	30	25
I	inch	2.7	3.2
	mm	67.5	81.5
L	inch	10.2	10.2
	mm	260	260
L ₁	inch	5.1	5.1
	mm	130	130
O	inch	2.2	2.7
	mm	55	68
T	inch	5.7	5.9
	mm	144	151

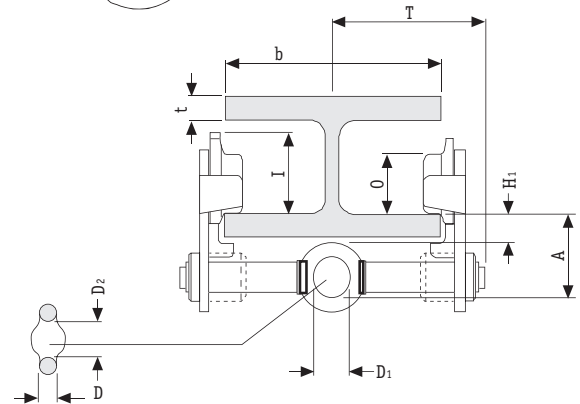

Distributed by Ergonomic Partners
 Sales@ErgonomicPartners.com
 www.ErgonomicPartners.com
 Tel: 314-884-8884