



- Pull cord control provides a lightweight, economical hoist for accurate control of loads
- Pendant throttle control hoists offer ergonomic one-handed controls, for ease of operation
- Inlet air swivel with built-in strainer provides free hoist movement
- Aluminum frame and end cover contributes to the lightweight, easily portable, and rugged design
- Heavy duty shoe type brake is a proven design for stopping and holding loads in heavy duty applications
- External adjustment screws for decreased lift and lower speeds
- External brake adjustment
- Limit stops prevent over-travel in upper and lowering directions
- Equa-torque gearing of alloy steel, heat treated spur gears is accurately machined to provide a close meshed, compact gear reduction
- Eight-vane motor provides high torque, smooth starting and excellent control
- Tapped exhaust port 1/2 NPTF... for CLEAN applications or to add a supplemental muffler in addition to the built-in muffler for even quieter operation

Basic Hoist Data

Rated Loads

1/4, 1/2, and 1-ton (Spark resistant models are rated at 3/8 and 3/4-ton).

Air Pressure Recommended
90 PSI

Air Consumption

48 SCFM at 90 PSI

Pendant Control Hose

6 foot length is standard. Longer lengths are an optional extra up to 72ft available.

Control

Pull cord or pendant throttle

Lift

10 foot lifts are standard. Additional lifts available.

Net Weight (Basic Hoist)

36 lbs.

Suspension

Hook or lug

Air Inlet Size

3/8 NPTF

Air Supply Hose Size

1/2 I.D. min.

Air Exhaust

1/2 NPTF

Hook & Lug Suspension Specifications

Type	Capacity	Pull Cord Control		Pendant Throttle Control		Parts of Load Chain	Lifting Speed Max**	Lowering Speed Max**
		Model #	Net Weight	Model #	Net Weight			
tons	tons		lbs.		lbs.	in	in	in
Hook Mount Trolleys								
Standard Models								
Roller Chain	1/4	2201	37	2202	47	1	65	95
	1/2	2203	37	2204	47	1	45	120
	1	2205	51	2206	61	2	23	60
Link Chain	1/4	2211	36	2212	46	1	65	95
	1/2	2215	36	2216	46	1	45	120
	1	2219	49	2220	59	2	23	60
Spark Resistant Models								
Link Chain	3/8	2241	36	2242	46	1	60	100
	3/4	2243	49	2244	59	2	29	52
Lug Mount Trolleys								
Standard Models								
Link Chain	1/4	2251	36	2252	46	1	65	95
	1/2	2255	36	2256	46	1	45	120
	1	2259	49	2260	59	2	23	60
Spark Resistant Models								
Link Chain	3/8	2281	36	2282	46	1	60	100
	3/4	2283	49	2284	59	2	29	52

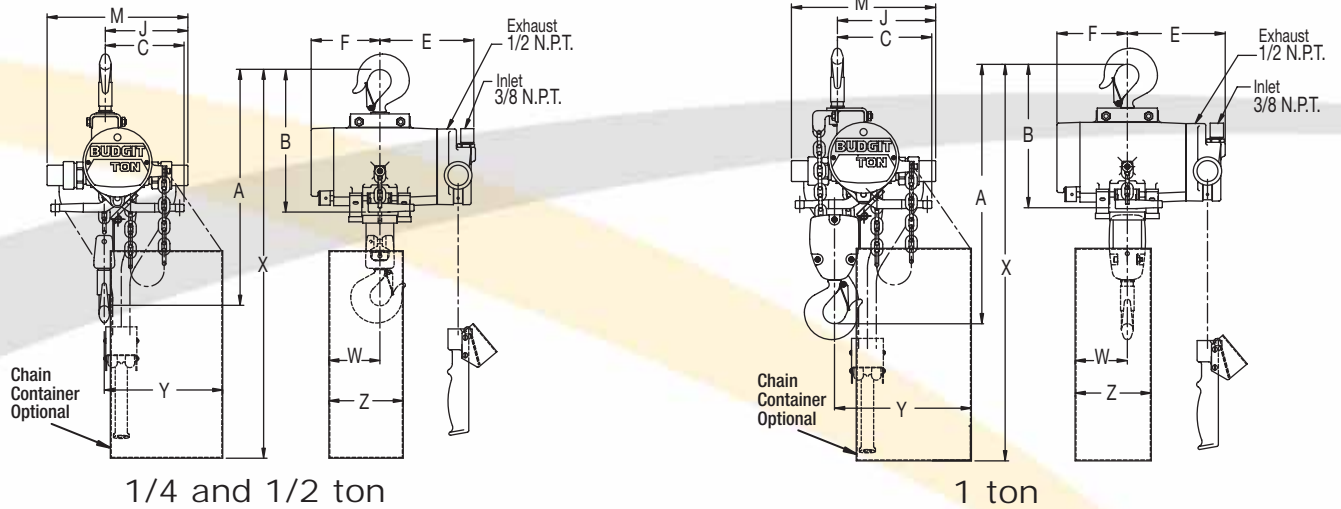

Hook Suspension Specifications & Dimensions

Type	Capacity	Pull Cord Control Model #	Pendant Throttle Control Model #	A	B	C	E	F	J	M	W	X	Y	Z	
tons	tons			in	in	in	in	in	in	in	in	in	in	in	
Standard Models															
Roller Chain	1/4	2201	2202	15-1/4	10-1/4	4-3/4	7-1/16	5-1/16	6-15/16	10-3/16	3-5/8	30-1/8	8-9/16	5-1/4	
	1/2	2203	2204	15-1/4	10-1/4	4-3/4	7-1/16	5-1/16	6-15/16	10-3/16	3-5/8	30-1/8	8-9/16	5-1/4	
	1	2205	2206	18	10-1/4	5-3/4	7-1/16	5-1/16	6-15/16	10-3/16	3-5/8	30-1/8	9-11/16	5-1/4	
Link Chain	1/4	2211	2212	15-1/4	10-1/4	4-3/4	7-1/16	5-1/16	6-15/16	10-3/16	3-5/8	30-1/8	8-9/16	5-1/4	
	1/2	2215	2216	15-1/4	10-1/4	4-3/4	7-1/16	5-1/16	6-15/16	10-3/16	3-5/8	30-1/8	8-9/16	5-1/4	
	1	2219	2220	18	10-1/4	5-3/4	7-1/16	5-1/16	6-15/16	10-3/16	3-5/8	30-1/8	9-11/16	5-1/4	
Spark Resistant Models															
Link Chain	3/8	2241	2242	15-1/4	10-1/4	4-3/4	7-1/16	5-1/16	6-15/16	10-3/16	*	*	*	*	
	3/4	2243	2244	18	10-1/4	5-3/4	7-1/16	5-1/16	6-15/16	10-3/16	*	*	*	*	

* Spark resistant chain container dimensions can be found in the Air Hoist Accessories section of this brochure

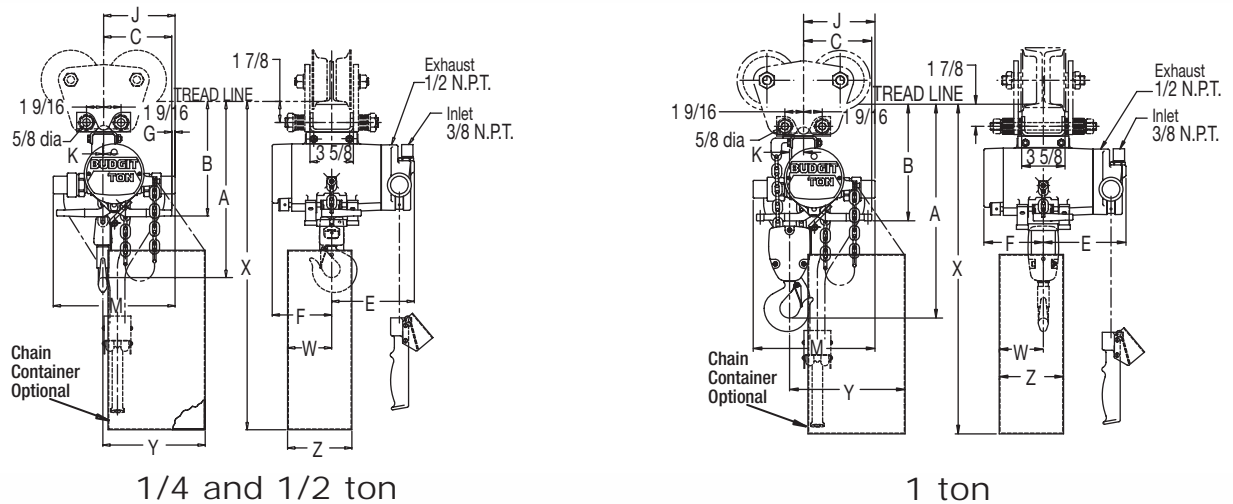

Lug Suspension Specifications & Dimensions

Type	Capacity	Pull Cord Control Model #	Pendant Throttle Control Model #	A	B	C	E	F	G	J	K	M	W	X	Y	Z
tons	tons			in	in	in	in	in	in	in	in	in	in	in	in	in
Standard Models																
Link Chain	1/4	2251	2252	13-7/8	9-5/8	4-3/4	7-1/16	5-1/16	1-1/4	6	1/16	10-3/16	3-5/8	29-1/4	8-9/16	5-1/4
	1/2	2255	2256	13-7/8	9-5/8	4-3/4	7-1/16	5-1/16	1-1/4	6	1/16	10-3/16	3-5/8	29-1/4	8-9/16	5-1/4
	1	2259	2260	17	9-3/4	5-3/4	7-1/16	5-1/16	1/4	6	1-3/16	10-3/16	3-5/8	29-1/4	9-11/16	5-1/4
Spark Resistant Models																
Link Chain	3/8	2281	2282	13-7/8	9-5/8	4-3/4	7-1/16	5-1/16	1-1/4	6	1/16	10-3/16	*	*	*	*
	3/4	2283	2284	17	9-3/4	5-3/4	7-1/16	5-1/16	1/4	6	1-3/16	10-3/16	*	*	*	*

* Spark resistant chain container dimensions can be found in the Air Hoist Accessories section of this brochure