

Model ALM
 Air Chain Hoist
 1 - 24 Ton Capacity

Pneumatic Chain Hoist

- **CAPACITIES & LIFT** - Rated loads 1 ton to 24 tons with standard lift of 10 feet.
- **ULTRA-LOW HEADROOM** - Design allows this hoist to operate in extreme low overhead locations where most other “low headroom” hoists can’t.
- **COMPACT DESIGN** - Integral hoist/trolley design provides compact overall envelope dimensions.
- **STRONG AND DURABLE** - Steel construction to withstand harsh environments.
- **HOISTING CONTROL** - Pilot air control permits variable speed hoisting and trolley traverse.
- **LIMIT SWITCH** - Redundant limit switches for upper and lower hook travel.
- **TROLLEY** - Plain, hand geared, or motor driven trolley models featuring anti-tilt rollers.
- **CUSTOM FIT** - Can be made to fit virtually any beam.
- **EASY INSTALLATION** - Unique design allows easy installation on closed end monorail beam.
- **OPTIONS** - Spark resistant packages, corrosion resistant finishes, swivel trolleys for curved monorails, e-stop on control pendant, chain container, rubber trolley bumpers and anti-drop lugs.

SPECIFICATIONS

1 - 24 Ton

Catalog Number			Rated Capacity in Short Tons	Standard Lift (ft.)	*Minimum Radius Curve	Minimum Distance from Bottom of I-Beam to Hook	Nominal Hoist Speed (FPM)	CFM @ 90 PSI	Net Weight, Lbs.		
Plain	Hand Geared	Motorized							Plain	Hand Geared	Motorized
ALP-1	ALG-1	ALM-1	1	10	6'6"	7"	10	265	480	510	560
ALP-1 1/2	ALG-1 1/2	ALM-1 1/2	1 1/2	10	6'6"	7"	10	265	480	510	560
ALP-2	ALG-2	ALM-2	2	10	6'6"	7"	10	265	480	510	560
ALP-3	ALG-3	ALM-3	3	10	6'6"	8"	5	265	580	610	660
ALP-4	ALG-4	ALM-4	4	10	7'6"	8 1/2"	5	265	580	610	660
ALP-5	ALG-5	ALM-5	5	10	8'6"	9 1/2"	7	350	1640	1700	1680
ALP-6	ALG-6	ALM-6	6	10	8'6"	9 1/2"	7	350	1640	1700	1680
ALP-8	ALG-8	ALM-8	8	10	9'6"	12"	4	350	1710	1840	1770
ALP-10	ALG-10	ALM-10	10	10	10'	12 1/2"	3.5	350	2090	2170	2150
ALP-12	ALG-12	ALM-12	12	10	*	12 1/2"	3.5	350	2090	2170	2150
ALP-16	ALG-16	ALM-16	16	10	*	14 1/2"	2	350	2660	2740	2720
ALP-20	ALG-20	ALM-20	20	10	*	18"	1.7	350	3010	3170	3120
ALP-24	ALG-24	ALM-24	24	10	*	18"	1.7	350	3010	3170	3120

* Please consult the factory

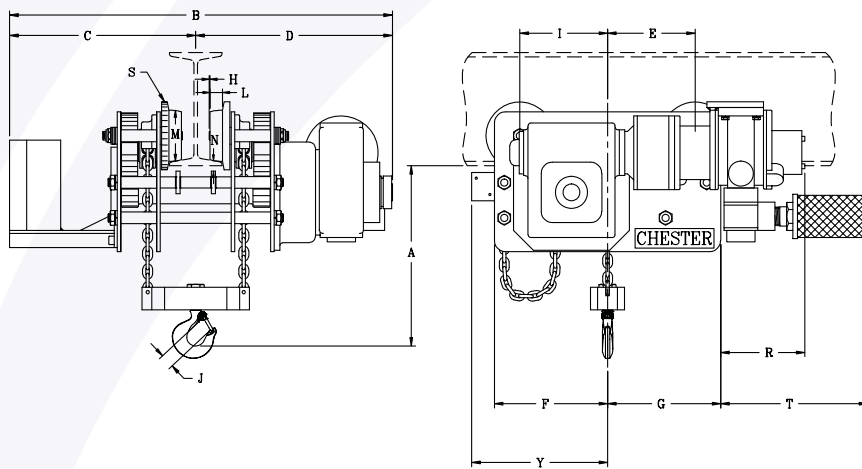

Minimum Radius Curve

Capacity	Minimum Radius Curve
1 1/2 - 2 Ton	6' 6"
3 - 4 Ton	6' 6"
5 - 6 Ton	8' 6"
8 Ton	9' 6"
10 Ton	10' 0"

For over 10 Ton, straight track operations is recommended.

Curve radius must be specified on orders.

Curves less than minimum radius may be fitted upon application.

CLEARANCE DIMENSIONS

PLAIN OR GEARED

Capacity	A	B	C	D	E	I	F	G	H***
Ton	in.	in.	in.	in.	in.	in.	in.	in.	in.
1	7	35 5/8	16 1/2	19 1/8	7 3/4	7 3/4	10	10	1/16
1 1/2	7	35 5/8	16 1/2	19 1/8	7 3/4	7 3/4	10	10	1/16
2	7	35 5/8	16 1/2	19 1/8	7 3/4	7 3/4	10	10	1/16
3	8	35 5/8	16 1/2	19 1/8	9	9	13	13	1/4
4	8	35 5/8	16 1/2	19 1/8	9	9	13	13	1/4
5	9 1/2	48 5/32	23 1/2	24 21/32	7 3/8	7 3/8	12	15	0
6	9 1/2	48 5/32	23 1/2	24 21/32	7 3/8	7 3/8	12	15	0
8	12	48 5/32	23 1/2	24 21/32	8 3/8	8 7/8	14	13 1/2	3/16
10	12 1/2	48 5/32	23 1/2	24 21/32	8 1/2	9 3/4	15 5/8	14 3/8	3/8
12	12 1/2	48 5/32	23 1/2	24 21/32	8 1/2	9 3/4	15 5/8	14 3/8	3/8
16	14 1/2	53 7/32	25 1/2	27 23/32	11 7/8	11 7/8	18 5/8	18 5/8	3/8
20	18	53 7/32	25 1/2	27 23/32	12 1/8	12 1/8	19 1/4	19	3/8
24	18	53 7/32	25 1/2	27 23/32	12 1/8	12 1/8	19 1/4	19	3/8

Capacity	J	L	M	N	P*	R	S	T**	Z
Ton	in.	in.	in.	in.	in.	in.	in.	in.	in.
1	1 1/8	1 1/8	4 1/2	7/8	6"l@12.5#	5 1/4	6	15	15
1 1/2	1 1/8	1 1/8	4 1/2	7/8	6"l@12.5#	5 1/4	6	15	15
2	1 1/8	1 1/8	4 1/2	7/8	6"l@12.5#	5 1/4	6	15	15
3	1 11/32	1 11/32	6 3/8	15/16	8"l@18.4#	5 3/16	8	10 1/2	12
4	1 11/16	1 11/32	6 3/8	15/16	8"l@18.4#	5 3/16	8	10 1/2	12
5	1 11/16	1 13/32	7 3/16	1 1/8	10"l@25.4#		9 3/8	20 7/16	
6	1 11/16	1 13/32	7 3/16	1 1/8	10"l@25.4#		9 3/8	20 7/16	
8	2 1/16	1 11/16	8 1/4	1	10"l@25.4#		10	20 11/16	
10	2 1/4	1 3/4	9 3/4	1 1/8	12"l@31.8#		11 11/16	18 5/8	
12	2 1/4	1 3/4	9 3/4	1 1/8	12"l@31.8#		11 11/16	18 5/8	
16	3	2	11 3/4	1 1/8	15"l@42.9#		14 13/32	10 3/4	
20	3 5/8	2	11 3/4	1 3/16	18"l@54.7#		14 13/32	11 1/8	
24	3 5/8	2	11 3/4	1 3/16	18"l@54.7#		14 13/32	11 1/8	

P* - Minimum standard I-beam for proper wheel running clearance only. Customers must verify their beam is adequate for the applied loading.

H*** - From the face of wheel to the end of the axle.

T** - For standard motor and brake only. Hoists are designed for H-3 duty.

CHESTER HOIST

A Columbus McKinnon Brand
Lisbon, OH

Distributed by Ergonomic Partners
Email: sales@ergonomicpartners.com
Web: www.ergonomicpartners.com
PH: 314-884-8884



CHE-ALH
SS 2.5M 0609 MU
Printed in USA
©2009 CMCO