

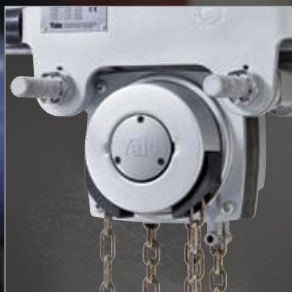

# HURRICANE™

HAND CHAIN HOIST



# LIFT AND POSITION FROM VIRTUALLY ANY ANGLE.

Because of its unique design, the versatility and safety benefits of the CM Hurricane 360° beats the competition. This one-of-a-kind hand chain hoist is ideal for use in the following applications:

## TIGHT SPACES

where the rigid handle of a lever hoist would be difficult to maneuver and operate. The Hurricane 360° allows you to easily work around obstructions.

## ABOVE THE LOAD

where traditional hoists cannot be used. The Hurricane 360°'s rotating hand chain guide allows for operation from virtually any angle.

## DRIFTING APPLICATIONS

when the hand chain angle needs to adjust throughout the operation. Using two Hurricane 360° hoists in tandem, operators can easily drift loads from one location to another.

## TO MAINTAIN SAFE DISTANCE

while handling a load. The rotating chain guide on the Hurricane 360° lets you conveniently maneuver a load without standing under or near it.



## TABLE OF CONTENTS

- |   |  |    |  |
|---|--|----|--|
| 4 | <b>CM HURRICANE 360°</b><br>Hook-mounted hoist models                  | 14 | <b>YALELIFT 360° ATEX</b><br>Hook-mounted and army-type,<br>integrated trolley hoist models<br>with explosion protection, spark<br>resistance and corrosion resistance |
| 8 | <b>CM HURRICANE 360°</b><br>Army-type, integrated trolley hoist models |    |  |





# HURRICANE<sup>TM</sup>

## HAND CHAIN HOIST

# 360°

The CM Hurricane 360° is unlike any other hand chain hoist on the market today. Featuring a one-of-a-kind hand chain cover, the CM Hurricane 360° provides flexibility and versatility for challenging applications.

The Hurricane's patented hand chain cover rotates a full 360 degrees, allowing loads to be lifted, positioned or pulled from virtually any angle – even in confined spaces. It also permits the operator to stand safely away from the load, helping to prevent accidents and injuries.

## HOOK-MOUNTED HOISTS

### 1/2 TO 20 TON CAPACITIES STANDARD LIFTS UP TO 30 FT.

#### BENEFITS & FEATURES

##### PATENTED HAND CHAIN COVER

Unique rotating hand chain cover allows the chain to rotate a full 360 degrees for safe and efficient operation from any direction. Cover design promotes smooth movement of the chain.

##### TRUSTED RELIABILITY & SAFETY

The Weston-style braking system provides positive load control and reliable performance. Standard load limiter provides simple, automatic overload protection to prevent injuries.

##### RUGGED & DURABLE FOR LONG LIFE

Internal gears and pinions are made of heat-treated steel for high strength and long life. Powder-coated finish provides protection against corrosion. Precision 4-pocket liftwheel and chain guide provide better chain fit and alignment to reduce wear.

##### EASE OF MAINTENANCE

Hoist requires minimal maintenance and can be easily disassembled with standard tools.

##### FAST & EASY PARTS ACCESS

Genuine CM Hurricane 360° parts are available in Total Repair Kits and convenient bulk packaging through CM Parts Star™.

##### MEETS ASME B30.16 & EUROPEAN CE STANDARD

##### ADDITIONAL OPTIONS AVAILABLE

Units are available with a variety of options to suit your application, including:

- Chain containers
- Zinc-plated load and hand chain
- Latchlok hooks
- Without standard load limiter



**LIFETIME  
WARRANTY™**

CM Hurricane 360° Hook-Mounted Hoist | 20-TON CAPACITY



The CM Hurricane 360° is available as a **hook-mounted hoist** in capacities from 1/2 to 20 tons, with standard lifts up to 30 feet.



**1/2-TON**  
CAPACITY

**1-TON**  
CAPACITY

**2-TON**  
CAPACITY

**3-TON**  
CAPACITY

**5-TON**  
CAPACITY



**10-TON  
CAPACITY**

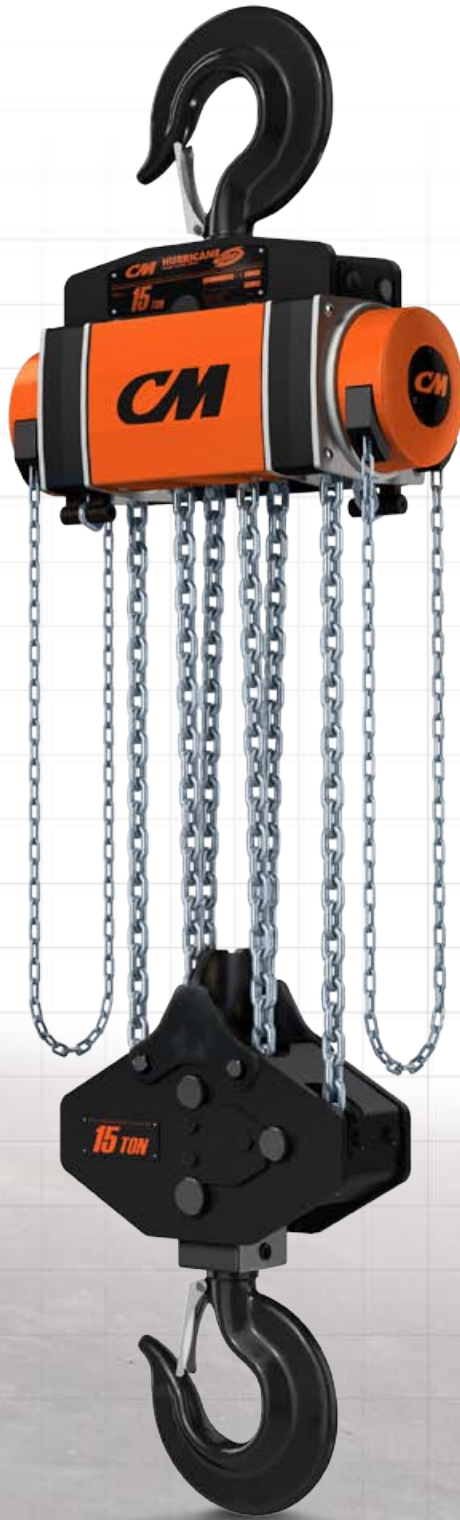

**15-TON  
CAPACITY**



**20-TON  
CAPACITY**

# HOOK-MOUNTED HOISTS

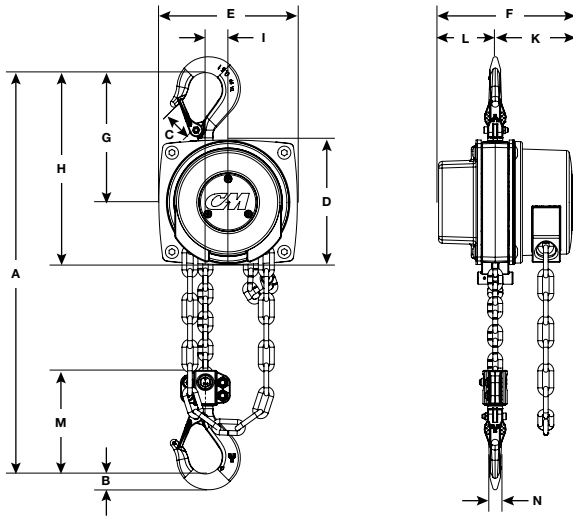

**HOOK-MOUNTED HOIST**  
**1/2 TO 3 TON**

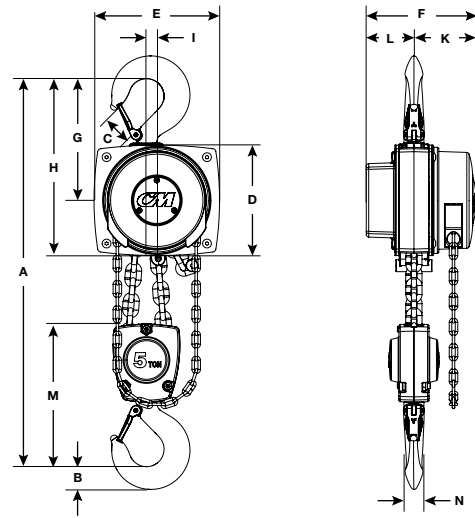

**HOOK-MOUNTED HOIST**  
**5 TON**

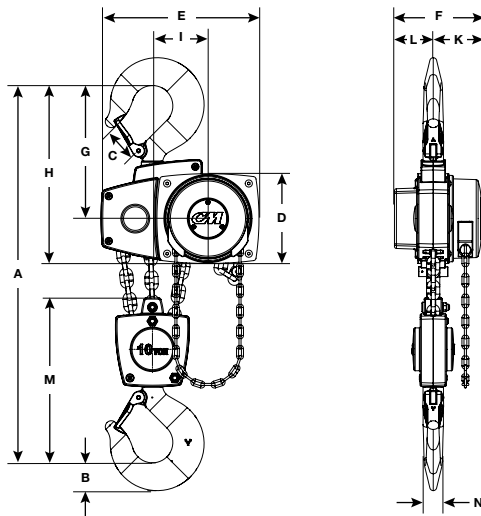

**HOOK-MOUNTED HOIST**  
**10 TON**

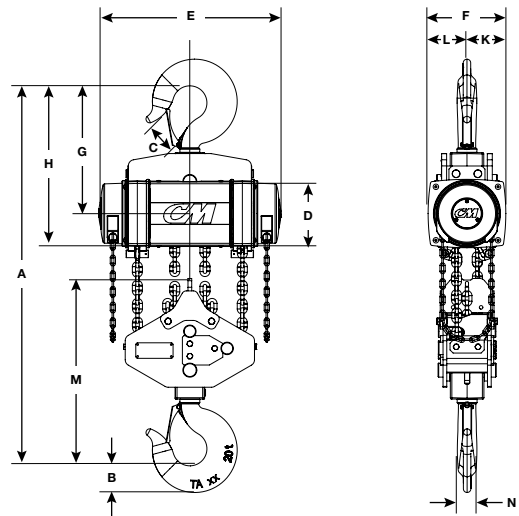

**HOOK-MOUNTED HOIST**  
**15 & 20 TON**



The CM Hurricane 360's unique rotating hand chain cover allows the chain to rotate a full 360 degrees for safe and efficient operation from almost any angle or direction.

**SPECIFICATIONS & DIMENSIONS**

Product Code	Capacity Ton (kg)	Lift		Weight lbs. (kg)	Reeving	Hand Chain Pull to Lift Rated Load lbs. (kg)	Hand Chain Overhauled to Lift Load One Foot ft. (m)	Dimensions in inches (mm)													
		ft.	m					A	B	C	D	E	F	G	H	I	K	L	M	N	
5623A	1/2 (500)	10	3	21 (9)	1	44 (20)	30 (9.1)	11.811 (300)	0.669 (17)	0.945 (24)	5.236 (133)	5.827 (148)	5.827 (148)	5.472 (139)	8.110 (206)	0.945 (24)	2.402 (61)	3.425 (87)	4.331 (110)	0.551 (14)	
5624A		15	4.5	23 (10)																	
5625A		20	6	25 (11)																	
5651A		30	9	29 (13)																	
5632A		Less Chain		17 (8)																	
5626A	1 (1,000)	10	3	28 (13)	1	54 (24)	49 (14.9)	13.189 (335)	0.866 (22)	1.142 (29)	6.142 (156)	6.890 (175)	6.575 (167)	6.457 (164)	9.528 (242)	0.945 (24)	2.756 (70)	3.819 (97)	4.921 (125)	0.748 (19)	
5627A		15	4.5	31 (14)																	
5628A		20	6	34 (15)																	
5653A		30	9	40 (18)																	
5633A		Less Chain		23 (10)																	
5629A	2 (2000)	10	3	47 (21)	1	74 (34)	71 (21.6)	15.551 (395)	1.181 (30)	1.378 (35)	7.165 (182)	7.992 (203)	7.638 (194)	7.559 (192)	11.142 (283)	1.220 (31)	3.268 (83)	4.370 (111)	6.142 (156)	0.866 (22)	
5630A		15	4.5	52 (24)																	
5631A		20	6	57 (26)																	
5634A		30	9	65 (29)																	
5635A		Less Chain		36 (16)																	
5635A	3 (3,000)	10	3	75 (34)	1	92 (42)	87 (26)	20.472 (520)	1.496 (38)	1.575 (40)	8.661 (220)	9.843 (250)	8.622 (219)	8.858 (225)	13.189 (335)	1.339 (34)	3.740 (95)	4.882 (124)	7.008 (178)	1.181 (30)	
5636A		15	4.5	82 (37)																	
5637A		20	6	89 (40)																	
5638A		30	9	97 (44)																	
5639A		Less Chain		52 (24)																	
5639A	5 (5,000)	10	3	106 (48)	2	76 (34)	174 (53)	25.748 (654)	1.772 (45)	1.850 (47)	8.661 (220)	9.843 (250)	8.622 (219)	9.528 (242)	13.858 (352)	0.827 (21)	3.740 (95)	4.882 (124)	11.220 (285)	1.457 (37)	
5640A		15	4.5	121 (55)																	
5641A		20	6	136 (62)																	
5642A		30	9	151 (68)																	
5643A		Less Chain		74 (34)																	
5643A	10 (10,000)	10	3	217 (98)	3	102 (46)	261 (79.3)	32.480 (825)	2.677 (68)	2.677 (68)	8.661 (220)	15.079 (383)	8.622 (219)	12.835 (326)	17.165 (436)	5.354 (136)	3.740 (95)	4.882 (124)	15.787 (401)	1.969 (50)	
5644A		15	4.5	240 (109)																	
5645A		20	6	261 (118)																	
5646A		30	9	282 (127)																	
5646A		Less Chain		168 (76)																	
HU15000H10	15 (15,000)	10	3	455 (206)	6	2 x 76 (2 x 34)	522 (2 x 261) (159.1 (2 x 79.3))	43.543 (1106)	3.386 (86)	3.150 (80)	8.661 (220)	23.071 (586)	9.843 (250)	16.181 (411)	20.512 (521)	-	4.921 (125)	4.921 (125)	23.740 (603)	2.480 (63)	
HU15000H15		15	4.5	508 (230)																	
HU15000H20		20	6	554 (251)																	
HU15000H30		30	9	653 (296)																	
HU20000H10	20 (20,000)	10	3	455 (206)	6	2 x 102 (2 x 46)	522 (2 x 261) (159.1 (2 x 79.3))	43.543 (1106)	3.386 (86)	3.150 (80)	8.661 (220)	23.071 (586)	9.843 (250)	16.181 (411)	20.512 (521)	-	4.921 (125)	4.921 (125)	23.740 (603)	2.480 (63)	
HU20000H15		15	4.5	508 (230)																	
HU20000H20		20	6	554 (251)																	
HU20000H30		30	9	653 (296)																	

Other lifts available. Contact factory.  
Standard Hand Chain drop 2 ft. less than Lift.

**DEMAND GENUINE PARTS**

When you choose Parts Star™ by Columbus McKinnon, you'll be purchasing genuine Columbus McKinnon parts designed to fit the Hurricane 360° hoist's exact specifications, maintaining warranty requirements and the integrity of the unit's superior design and safety features.

Get everything you need for a complete and professional repair with Parts Star Total Repair Kits. Popular Hurricane 360° repair parts are also available in easy-to-order bulk packaging so the parts you need are always on hand.



**PROTECT AGAINST UNSAFE LIFTING CONDITIONS**

All CM Hurricane 360° units feature the Tri-Point Hook Inspection™ system to help protect the operator against unsafe lifting conditions. Hurricane 360° load hooks come with 3 distinct raised points the operator can use to measure the hook to detect any indication of overload or deformation.





# HURRICANE<sup>TM</sup>

## HAND CHAIN HOIST

# 360°

The CM Hurricane 360° is available as an army-type, integrated trolley hoist, uniquely and smartly designed for a variety of applications. With all of the same great general features as the hook-mounted version, these compact units feature a low-headroom design for use in even the tightest spaces.

## ARMY-TYPE, INTEGRATED TROLLEY HOIST

**1/2 TO 20 TON CAPACITIES  
STANDARD LIFTS UP TO 30 FT.**

### ADDITIONAL FEATURES

#### LOW HEADROOM DESIGN

The combination of the versatile CM Hurricane 360 with a low-headroom trolley provides even more flexibility in applications with low ceilings or limited space. Trolleys have reduced side clearances and end approach to aid in maneuvering heavy loads in tight spaces.

#### ADJUSTABLE & VERSATILE

Choose from plain or geared versions. These manual trolleys can be easily adjusted to fit to a wide range of beam widths and profiles due to threaded spindles (e.g. INP, IPE, IPB). Depending on the beam flange width, an adjustment up to 300 mm can be made easily.

#### SMOOTH OPERATION

Trolley wheels are designed for smooth rolling with pre-lubricated encapsulated ball bearings. Wheels manufactured from fracture-proof steel. Cambered profile suitable for flat and inclined beam profiles. Note: Trolley wheels are designed for a max. beam profile incline of 14% (DIN 1025 - part 1).

#### BEST-IN-CLASS SAFETY FEATURES

Standard anti-tilt and anti-drop features. Load limiter also comes standard to protect against dangerous overloads. Rubber bumpers optional for added safety.

#### RUGGED & DURABLE

Steel load bars are connected directly to the hoist frame for added strength and durability.

#### ADDITIONAL OPTIONS AVAILABLE

Units are available with a variety of options to suit your application, including:

- Chain containers
- Zinc-plated load and hand chain
- Latchlok hooks
- Without standard load limiter
- Trolley guards
- Larger beam trolleys
- Track clamps
- Rubber bumpers

**LIFETIME  
WARRANTY<sup>TM</sup>**



PLAIN  
MODEL



GEARED  
MODEL



**LIFT AND POSITION  
FROM VIRTUALLY ANY ANGLE.**

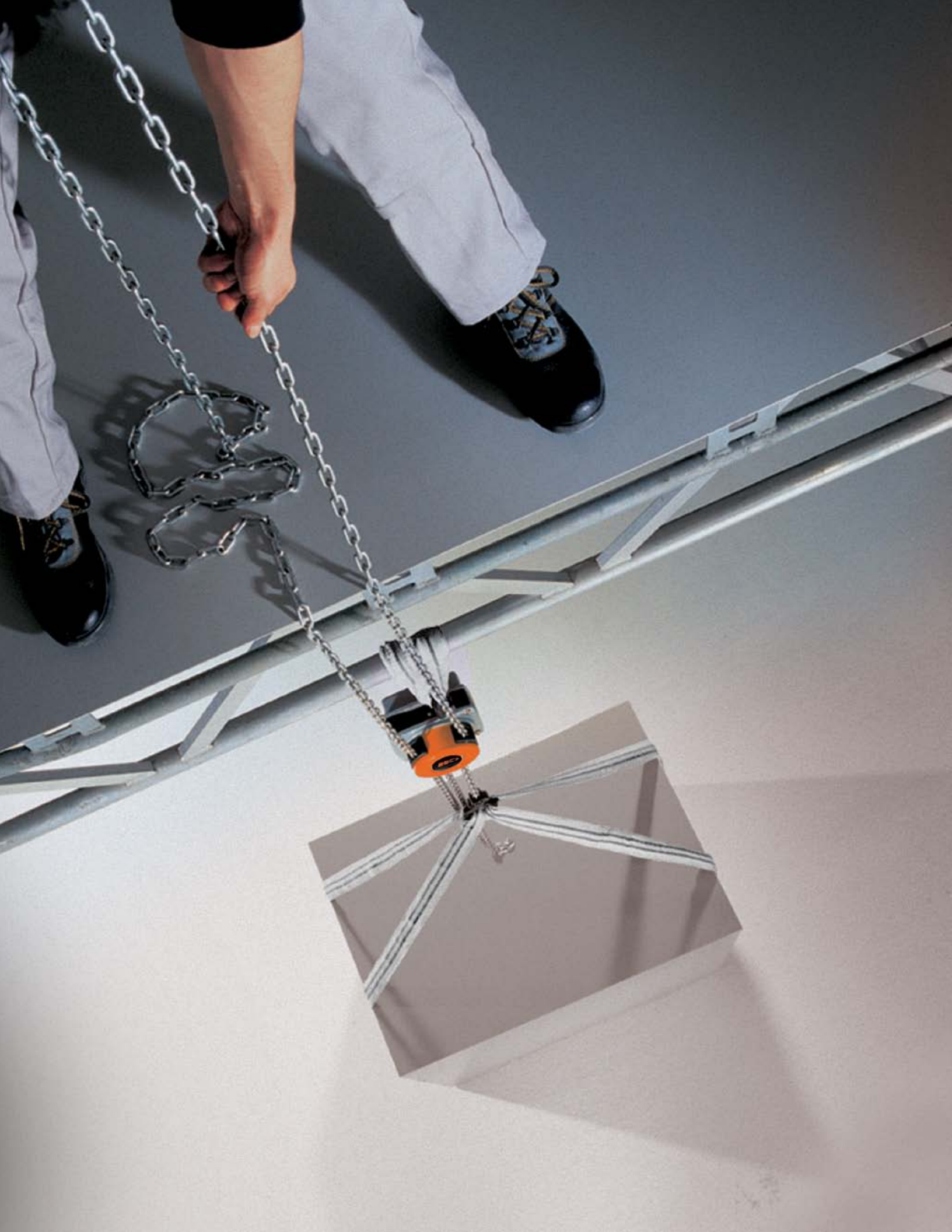

## YOUR ONE SOURCE FOR FLOOR-TO-CEILING SYSTEMS

Since 1875, Columbus McKinnon has helped to make material handling easier and safer, and, today, is your single source for complete floor-to-ceiling lifting systems.

From below-the-hook attachments, chain, rigging products, manual and powered chain hoists to electric wire rope hoists, cranes, enclosed track systems and specially engineered products, Columbus McKinnon has the engineering expertise to meet the most demanding applications.



## KNOW HOW. KNOW WHY.

Columbus McKinnon is committed to providing expert safety training on the proper use and inspection of rigging and overhead lifting equipment. Our company offers comprehensive programs at our national training centers as well as on-site at your facility. Courses include:

- Hoist Maintenance
- Safe Hoisting
- Rigging Gear Inspection
- Crane & Hoist Inspection
- Load Securement
- Crane Operator Training
- Rigging



Win in the marketplace with **CMCO University™**. This three-day program is designed to give Channel Partners intimate product and application knowledge that they can use to advise their end-user customers during the product selection and sales processes.

Columbus McKinnon's corporate headquarters in Getzville, New York, is home to our state-of-the-art **Niagara Training Center**. The 3,000-square-foot facility is dedicated to training Channel Partners and end users on the safe and proper use of hoist and rigging products. The Center offers a one-of-a-kind training experience on chain and rigging equipment with more than 75 manual and powered hoists, enclosed track systems and our 50-foot-wide crane system with 3-ton Yale Global King wire rope hoist.



Distributed by Ergonomic Partners

Sales@ErgonomicPartners.com

USA (314) 884-8884

[www.ErgonomicPartners.com](http://www.ErgonomicPartners.com)