

# Operating Instructions

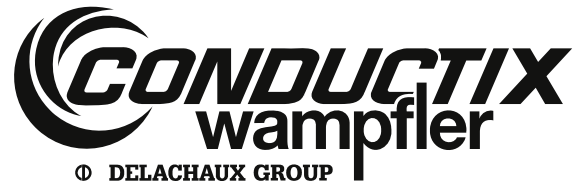

## Spring Balancer EWF-9 to EWF-70

BAL0400-1014a-US

### Order-Number

- XA-EWF-9
- XA-EWF-15
- XA-EWF-22
- XA-EWF-30
- XA-EWF-40
- XA-EWF-50
- XA-EWF-60
- XA-EWF-70



Distributed by Ergonomic Partners

[Sales@ErgonomicPartners.com](mailto:Sales@ErgonomicPartners.com)

[www.ErgonomicPartners.com](http://www.ErgonomicPartners.com)

Tel: (314) 884-8884

### **WARNING**

- Read this manual before use.
- Keep this manual available.

## SAFETY ALERT SYMBOL AND ALERT SIGNS

Please read this manual carefully and follow this instructions.

The SAFETY ALERT SYMBOL (  ), **WARNING**, **CAUTION**, and **NOTE** carry special messages.



This **SAFETY ALERT SYMBOL** is used to call your attention to items or operations that could be dangerous to you or other persons using this equipment.

Please read these messages and follow these instructions carefully.



**WARNING** : **WARNING** indicates a hazardous situation which, if not avoided, could result in death or serious injury.



**CAUTION** : **CAUTION** indicates a hazardous situation which, if not avoided, could result in minor or moderate injury, damage or destruction of the equipment and others.

**NOTE** : **NOTE** indicates a special instructions in operation or maintenance.

## Contents

<b>1. ▲ Safety instructions</b> .....	4
<b>2. Description of product</b> .....	5
2-1. Specifications	
2-2. Main features	
<b>3. Installation</b> .....	5
3-1. Balancer installation	
3-2. Tool/device attachment and spring tension adjustment	
3-3. Working stroke (cable travel) check	
<b>4. Use</b> .....	7
4-1. Safety instructions on use	
4-2. Drum lock operation	
4-3. Tool/device replacement	
<b>5. Troubleshooting</b> .....	9
5-1. Common malfunctions and their causes	
5-2. Solutions	
<b>6. Inspections</b> .....	11
<b>7. Wire rope replacement</b> .....	12
<b>8. Spring replacement</b> .....	12
<b>9. Wire guide replacement</b> .....	14
<b>10. Parts list</b> .....	15
EWF- 9, EWF-15 .....	15
EWF-22, EWF-30 .....	17
EWF-40, EWF-50 .....	19
EWF-60, EWF-70 .....	21

## 1. ⚠ Safety instructions

### ⚠ WARNING

Incorrect use of the spring balancer could cause personal injury.  
Observe instructions in the manual and use the balancer correctly.

- Install the balancer correctly.
- Always attach a secondary support cable or chain.



- Never stand under the suspended tool/device.



- Never remove tool/device while the wire rope is extended.
- Never pull the wire rope when unloaded. Never release the drum lock when unloaded.

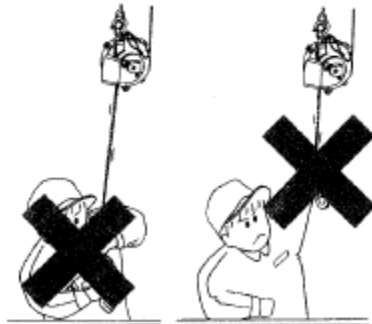

- Never remove the spring from the spring case.



- Never alter the balancer.
- Periodically inspect the balancer.

**2. Description of product**

2-1. Specifications

Model	Capacity range (kg)	Cable travel (m)	Mass (kg)
EWF- 9	4.5- 9.0	1.3	3.5
EWF-15	9.0-15.0	1.3	3.8
EWF-22	15.0-22.0	1.5	7.3
EWF-30	22.0-30.0	1.5	7.7
EWF-40	30.0-40.0	1.5	9.7
EWF-50	40.0-50.0	1.5	10.1
EWF-60	50.0-60.0	1.5	11.1
EWF-70	60.0-70.0	1.5	11.4

Working conditions and application area : Indoor and normal atmospheric conditions  
 Temperature range : -10°C to + 50°C

2-2. Main features

- Fall prevention device:  
 Mechanism to prevent the suspended tool/device from falling to the maximum cable travel in case of spring breakage.  
 When the spring breaks, the safety pin pops out from the spring case and collides with one of the pins, which are fixed on the casing, to stop the drum rotating.  
**This mechanism can not prevent the tool/device from falling at all when the spring breaks.**
- Drum lock (See Chapter 4-2 "Drum lock operation");  
 Mechanism to lock the drum every 1/6 turns.  
 The mechanism is used when removing the suspended tool/device (see Chapter 4-3) or replacing the wire rope (see Chapter 7) or replacing the wire guide (see Chapter 9).

**3. Installation**

3-1. Balancer installation

**⚠ WARNING**

- **Install the balancer correctly.**  
 Incorrect installation could cause personal injury or damage to the balancer or other equipment.
- **Always attach a secondary support cable or chain.**  
 It is required to protect worker(s) in case of failure of the top hook or the fitting.

- 1) Prepare a fitting that can support at least 10 times the maximum capacity of the balancer.  
**NOTE :** The fitting must have no opening as shown in Fig. 1 to prevent the balancer from disengaging when it swings.
- 2) Attach the top hook of the balancer directly to the fitting.  
 Check the latch is closed.  
**NOTE :** Take care the balancer does not hit surrounding objects.  
 Make different mounting heights for each balancer to avoid collision.
- 3) Check the top hook can swivel freely.  
**NOTE :** Do not fasten the top hook to the balancer body.
- 4) Prepare a secondary support cable or chain that can support at least 10 times the maximum capacity of the balancer.

- 5) As shown in Fig. 1, attach an end of the secondary support cable or chain to balancer body, and attach the other end to a separate fitting which does not support the balancer.

**NOTE :** Leave some slack in the secondary support cable or chain to allow the balancer to rotate freely. The slack must be a suitable length so that the balancer will stop within 100mm when falling in case of failure of the top hook or the fitting (see Fig. 1) .

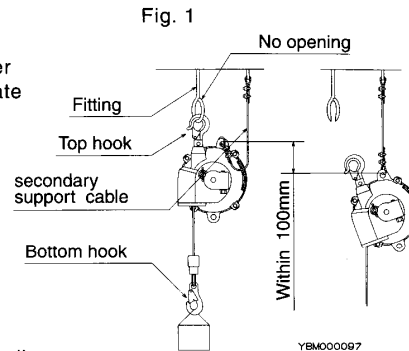

#### 3-2. Tool/device attachment and spring tension adjustment

### **WARNING**

**Never pull the wire rope when unloaded.**  
**If the wire rope is released when extended with no load, it will snap back and could cause personal injury.**

### **CAUTION**

**If the spring tension is set over the maximum capacity, the balancer can not provide the specified cable travel and the spring life will be shortened.**  
**If the spring tension is set under the minimum capacity, the fall prevention device will operate and stop the suspended tool/device.**

- 1) Before attaching, check the mass (weight) of the complete Tool/device, including all accessories, is within the capacity range of the balancer.
- 2) While watching the gauge, preadjust the spring tension to the mass of the complete tool/device by turning the worm with a wrench etc. Turn clockwise for increasing the spring tension, turn counterclockwise for decreasing. The gauge shows the approximate spring tension (see Fig. 2) .
- 3) Lift the complete tool/device up to the bottom hook and attach it. Never pull the wire rope down to the tool/device.
- 4) After attaching the complete tool/device, adjust the spring tension again and check tool/device is balanced.

**NOTE :** Over tensioning could cause damage to the balancer body or the wire rope.

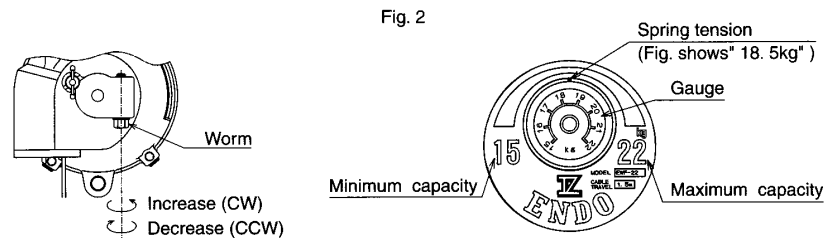

#### 3-3. Working stroke (cable travel) check

### **CAUTION**

**Extending the wire rope past the maximum cable travel could cause damage to the balancer.**

- 1) Check the cable travel is long enough for the application.
- 2) If necessary, lower the mounting height of the balancer or insert a suitable fitting between the bottom hook and tool/device.

#### 4. Use

##### 4-1. Safety instructions on use

### WARNING

- Never remove tool/device from the bottom hook while the wire rope is extended.
- Never stand under the suspended tool/device.
- Never alter the balancer.

### CAUTION

- Always use within the capacity range of the balancer.
- Always adjust the spring tension before use.
- Do not extend the wire rope past the maximum cable travel.
- Do not pull the wire rope at an angle.

##### 4-2. Drum lock operation

- 1) Pull Pin (8) out and turn it clockwise to place in the lock position (see Fig. 3).
- 2) Move the suspended tool/device upward or downward until Pin (8) enters the slot/hole in the drum and the drum becomes locked.
- 3) Move the tool/device again to check the drum is locked securely.
- 4) Remove the tool/device from the bottom hook.

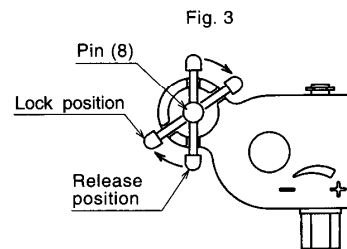

### WARNING

- Never remove the suspended tool/device before checking the drum is locked securely.
- If the drum is not locked securely, the drum lock could be released allowing the wire rope to snap back, possibly causing personal injury.

- 5) Before releasing the drum lock, attach a new tool/device if the old one has been removed.  
The new tool/device must have almost the same mass (weight) as the old one.
- 6) Release the drum lock by pulling Pin (8) out.  
Turn Pin (8) counterclockwise and place it in the release position.

### WARNING

- Never release the drum lock when the balancer is unloaded or the new tool/device has a different mass (weight) to the old one.  
If released, the wire rope will snap back or the tool/device could drop down respectively, possibly causing personal injury.
- Always release the drum lock after arranging the tension of spring suspending a tool. This is important factor for safety.

## Spring Balancer

### EWF-9 to EWF-70

BAL0400-1014a-US

#### 4-3. Tool/device replacement

##### ■ Method 1 - With drum lock actuated.

- 1) Lock the drum according to Chapter 4-2 "Drum lock operation"  
Remove the suspended tool/device.

#### **WARNING**

**Move the tool/device upward and downward to check the drum is locked securely. Never remove the tool/device before checking this. If the drum is not locked securely, the drum lock could be released allowing the wire rope to snap back, possibly causing personal injury.**

- 2) Before attaching, check the mass (weight) of the new complete tool/device, including all accessories, is within the capacity range of the balancer.
- 3) While watching the gauge, preadjust the spring tension to the mass of the new complete tool/device by turning the worm with a wrench etc.  
Turn clockwise for increasing the spring tension, turn counterclockwise for decreasing. The gauge shows the approximate spring tension (see Fig. 2) .
- 4) Attach the new complete tool/device to the bottom hook.  
Release the drum lock.

#### **WARNING**

- **Never release the drum lock when the balancer is unloaded, or if the new tool/device has a different (weight) to the old one, before readjusting the spring tension. If released, the wire rope will snap back or the tool/device could drop down respectively, possibly causing personal injury.**
- **Always release the drum lock after arranging the tension of spring suspending a tool. This is important factor for safety.**

- 5) After attaching the new complete tool/device and releasing the drum lock, adjust the spring tension again and check the tool/device is balanced.  
**NOTE :** Over tensioning could cause damage to the balancer body or the wire rope.

##### ■ Method 2 - Without drum lock actuated.

#### **WARNING**

**Never remove the suspended tool/device while the wire rope is extended. If removed, the wire rope will snap back and could cause personal injury.**

- 1) Lift then remove the suspended tool/device when the wire rope is fully retracted.
- 2) Attach a new tool/device according to Chapter 3-2 "Tool /device attachment and spring tension adjustment".

### 5. Troubleshooting

**⚠ WARNING**

- If a malfunction occurs during operation, stop operation immediately and take the necessary steps to rectify the problem.
- Never remove the suspended tool/device before identifying causes of the malfunction.  
If removed, the wire rope will snap back and could cause personal injury. Never take off a tool suspended to make the work safe.

#### 5-1. Common malfunctions and their causes

Malfunction	Cause	Solution
<ul style="list-style-type: none"> <li>● Wire rope can not be pulled out or retracted.</li> </ul>	<ul style="list-style-type: none"> <li>● Drum lock is engaged.</li> <li>● Fall prevention device is engaged because the spring tension is set under the maximum capacity.</li> <li>● Wire rope has slipped off from the drum groove and is caught between drum and casing.</li> <li>● Spring has broken.</li> </ul>	<ul style="list-style-type: none"> <li>● Release drum lock. See Chapter 4-2.</li> <li>● Release fall prevention device. See Chapter 5-2.</li> <li>● Return wire rope to the drum groove. See Chapter 5-2.</li> <li>● Replace spring. See chapter 8.</li> </ul>

Contact your dealer or us if a malfunction not listed above occurs.

#### 5-2. Solutions (Refer to the disassembly drawings on pages 15, 17, 19, and 21)

**⚠ CAUTION**  
Careless repairs can cause personal injury or damage to the balancer. Therefore, be careful but thorough when making repairs.

■ When the fall prevention device has engaged because the spring tension is set under the minimum capacity (see Fig. 4)

1) Move the suspended tool/device upward and downward by hand.

The tool/device can be moved about 70 to 140 mm.

If the tool/device rises after being lowered and then released, turn Worm (42) counterclockwise until the tool/device starts dropping down.

If the tool/device drops down after being lifted and then released, turn Worm clockwise until the tool/device starts rising.

2) Remove Wire guide (48) , (49) from Casing (1) .

3) Loosen Set screws (14) , and remove all Pins (13) while holding the tool/device by hand.

**NOTE : For safety reasons, perform this work with two persons.**

4) Lift then remove the tool/device from bottom Hook (32) when wire rope (30) is fully retracted into Drum (19).

Check the mass (weight) of removed tool/device is within the capacity range of the balancer.

5) Attach a weight, which has been confirmed that the weight is within the capacity range, to bottom Hook (32) and adjust the spring tension.

6) Move the tool/device upward or downward so that Safety pin (45) appears at the hole for Pin (13).

7) Check Safety pin (45) does not project out from the surface of Screw (47) .

If protruding, lightly tap the top of Safety pin with a Bar having 6mm dia.

8) If Safety pin does not return, it has burrs or Spring (46) is broken. Remove Screw (47)

after releasing Spring case (21) from Casing (1) according to chapter 8 " Spring replacement", 1) B - 9) .

Spring (46) pops out when Screw (47) is removed, therefore be careful not to lose it.

- 9) Screw removal requires screw reassembly in the method that the surface of Screw becomes even with Spring case (21).  
For preventing Screw (47) from loosening, make punch marks at 2 points on the thread with a punch.
- 10) Make reassemble procedure according to chapter 8 "Spring replacement", 13) -18).



### WARNING

If installation of Safety pin (45) or pins (13) is incorrect or missed, the fall prevention device will not operate in case of spring breakage, causing personal injury or damage to equipment.

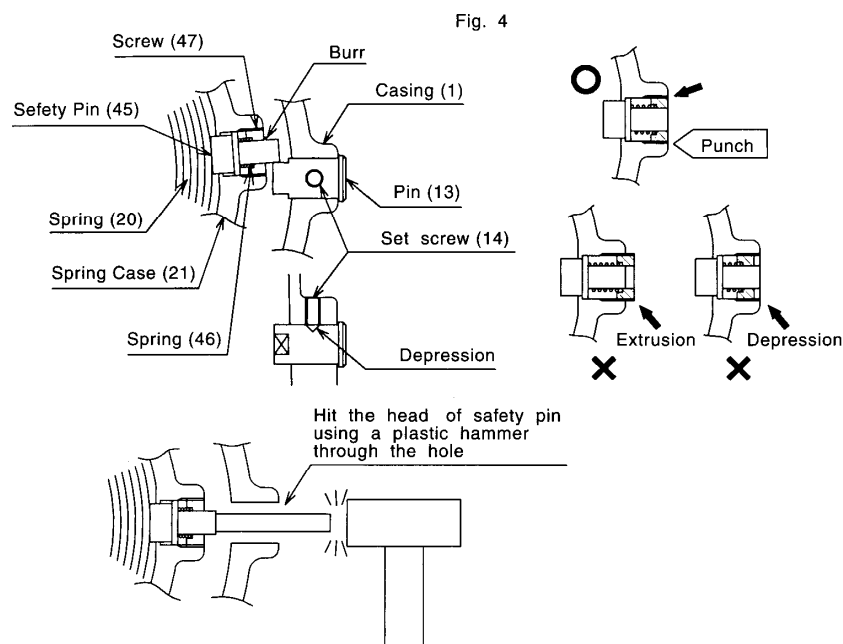

- When the wire rope is caught between drum and casing
  - 1) Release Wire rope (30) by jerking it strongly while the tool/device is suspended.  
**NOTE** : After jerking, check wire rope and replace if damaged.
  - 2) If Wire rope can not be released by jerking, disassembly is required. Remove Retaining ring (51) from worm (42) .
  - 3) Release all spring tension by turning Worm (42) counterclockwise, and remove Worm.
  - 4) Remove the tool/device from bottom Hook (32) , and remove the balancer from the fitting.
  - 5) Remove Wire guide (48) , (49) from Casing (1) .
  - 6) Loosen Set screws (14) , and remove all Pins (13) .
  - 7) Remove Gauge (43) .
  - 8) Loosen Hex. head bolts (29) , and remove Cover (27) .
  - 9) Return Wire rope (30) to the groove of Drum (19) .  
**NOTE** : Check wire rope (30) and replace if damaged.
  - 10) Install Cover (27) .
  - 11) Install Worm (42) , and attach Retaining ring (51) .
  - 12) Adjust the spring tension, and install Gauge (43) , Pins (13) , wire guide (48) and (49) . See Chapter 8 " Spring replacement", 13) - 18).

6. Inspections

**⚠ WARNING**  
 Periodically inspect the balancer, and replace any worn or damaged parts.

**⚠ CAUTION**  
 Always use genuine parts for replacement.

- Inspect the balancer at least once a month.  
 Correct and repair any problems which are detected.  
 Make the inspection interval shorter when operating frequently or under hostile environments. (See Fig. 5.)

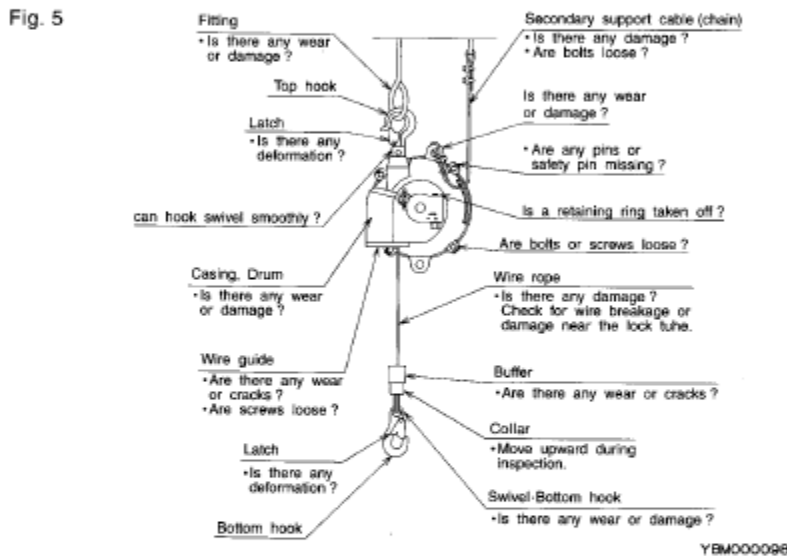

■ Service limit of top hook

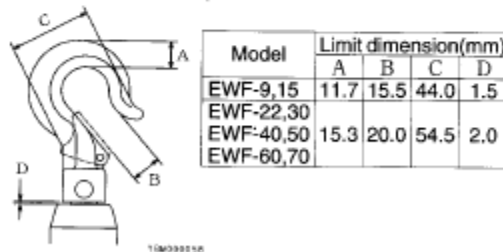

■ Service limit of bottom hook

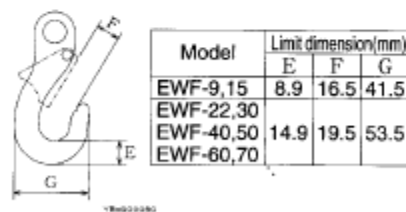

■ Service limit of wire rope

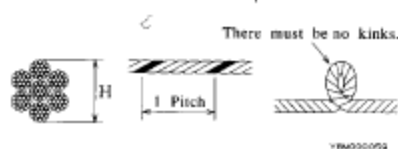

Model	H dimension(mm)		Allowable number of broken wires in 1 pitch
	Standard	Limit	
EWF-9,15	4.0	3.7	11
EWF-22,30			
EWF-40,50	4.76	4.3	13
EWF-60,70			

**7. Wire rope replacement**

- 1) Lower the tool/device, extending Wire rope to the maximum cable travel.
- 2) Position Plug (40) which is screwed on the drum, at the casing opening as shown in Fig. 6, and engage the drum lock. See. Chapter 4-2 "Drum lock operation".
- 3) Move the tool/device upward and downward to check Drum (19) is locked securely.  
Remove the tool/device from bottom Hook (32).

**⚠ WARNING**  
**Never remove the suspended tool/device before checking Drum (19) is locked securely.**  
**If Drum (19) is not locked securely, the drum lock could be released allowing Wire rope (30) to snap back or Drum to rotate suddenly, possibly causing personal injury.**

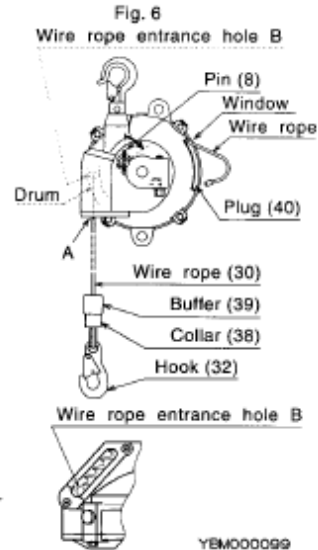

- 4) Remove the balancer from the fitting and place on the floor.
- 5) Remove Plug (40) and pull out an old wire rope from the drum. If the tip of wire rope stuck in drum, push the tip of wire rope into the drum using a driver or etc, and try again. (see Fig. 7)
- 6) Insert a new wire rope from the A-side into "Wire rope entrance hole B" and pass it through drum. If the wire rope is caught in the drum and doesn't pass through the drum, press and twist the Wire rope. This operation will make it easy to pass the wire rope through the drum.
- 7) Attach the end of Wire rope to drum and fasten with plug (40).
- 8) Install the balancer on the fitting.  
See Chapter 3-1 "Balancer Installation".
- 9) Attach the tool/device to bottom hook, and release the drum lock.

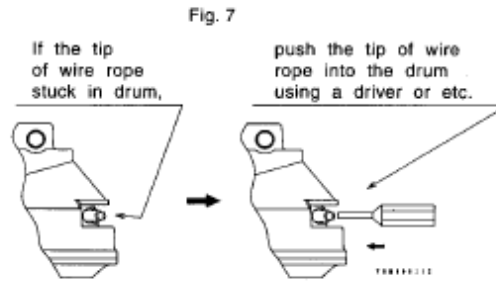

**⚠ WARNING**  
**Never release the drum lock before attaching the tool/device.**  
**If released, Wire rope will snap back and could cause personal injury.**

**8. Spring replacement**

**⚠ WARNING**

- Never remove the spring from the spring case.  
If removed, the spring will expand explosively and cause personal injury.
- Replace the spring assembly as a whole.

Referring to the disassembly drawings (on pages 23, 25, 27 and 29), disassemble the balancer using the following procedure.

- 1) A. When the spring has broken.
  - Single spring type : EWF-9, 15, 22 and EWF-30  
Remove the tool/ device from bottom Hook (32).

- Double spring type : EWF-40, 50, 60 and EWF-70



#### CAUTION

**EWF-40, 50, 60 and EWF-70 employ two springs, therefore some spring tension remains in case of one spring breakage. Be careful when disassembling.**

Lock Drum according to Chapter 4-2 "Drum lock operation", and remove the tool/device from bottom Hook (32).

- B. When the spring has not broken.
  - Lift, then remove the tool/device from bottom Hook (32) after Wire rope (30) is fully retracted into Drum (19).
  - 2) Remove the balancer from the fitting and place on the floor.
  - 3) Remove Gauge (43).
  - 4) Remove Retaining ring (51) from worm (42).  
Release all spring tension by turning worm counterclockwise until Worm can almost be removed. If the drum lock is activated, check there is no spring tension remaining, and then release the drum lock.  
**CAUTION : Check the spring tension by pulling Wire rope (30).**
  - 5) Turn the Worm (42) further and remove it.
  - 6) Remove Wire guide (48) , (49) from Casing (1) for EWF-22 to EWF-70.  
**NOTE :** Hex. Socket button bolts (50) are sealed against looseness. Always replace old ones with new ones when they are removed.
  - 7) Loosen Set Screws (14), and remove all Pins (13).
  - 8) Remove Plug (40) and pull out an old Wire rope (30) from Drum (19).  
If the tip of wire rope stuck in drum, push the tip of wire rope into the drum using a driver or etc, and try again. (see. Fig. 7)
  - 9) Remove Cover (27), and remove Spring Case (21), Drum (19), and Spindle (15) together from the Casing (1).
  - 10) Remove Spindle (15).
  - 11) Remove Hex. head bolts (24) , (25) and remove Spring Case (21) from Drum (19).
  - 12) Remove Bushing (23) from Spring Case (21).



#### WARNING

**Never remove Cover (22) from Spring case (21). If removed, the internal spring could pop out and cause personal injury.**

- 13) Reassemble in reverse order.
  - Pins (13) should be installed after adjusting the spring tension as instructed below.
- 14) Attach Wire guide (48) , (49) to Casing (1).  
**NOTE :** Hex. Socket button bolts (50) are sealed against looseness. Always replace old ones with new ones when they are removed. Tighten the hex. Socket bolts with torque of 2.8~3.0Nm { 0.28~0.3kgf-m}.
- 15) Wind the spring by turning Worm (42) clockwise.  
**NOTE :** While turning worm, Wire rope (30) will be retracted into Drum (19). Pay attention Wire rope dose not slip out from the drum groove. After Wire rope is fully retracted, turn Worm by the number of turns shown in Table 1.

Table 1

Model	Number of turns	Model	Number of turns
EWF- 9	60	EWF-40	105
EWF-15	50	EWF-50	95
EWF-22	75	EWF-60	115
EWF-30	80	EWF-70	90

- 16) Attach a weight, which has been confirmed that the weight is within the capacity range, to bottom Hook (32) and adjust the spring tension.
- 17) Attach and adjust Gauge (43).
- 18) Attach Pins (13) to Casing (1) (See Fig. 8). Fasten depressions in Pins with Set screws (14).

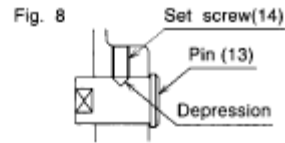

**⚠ WARNING**  
If installation of Pins (13) is incorrect or missed, the fall prevention device will not operate in case of spring breakage, causing personal injury or damage to equipment.

### 9. Wire guide replacement

- 1) Pull out the wire rope to the position which wire guide replacement is available and lock drum with drum lock device (refer to fig-9). Refer to Chapter 4-2 "Drum lock operation".
- 2) After confirming that drum lock is surely on work, moving a suspended tool up and down, take off a suspended tool.

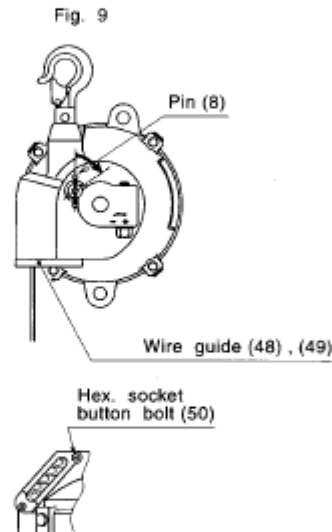

**⚠ WARNING**  
Never remove the suspended tool/device before checking Drum (19) is locked securely. If Drum (19) is not locked securely, the drum lock could be released allowing Wire rope (30) to snap back or Drum to rotate suddenly, possibly causing personal injury.

- 3) Remove the balancer from a fitting and place on the floor.
- 4) Remove Hex. Socket button bolts (50) and old wire guide from casing.
- 5) Fix new wire guide (48),(49).  
**NOTE** : Hex. Socket button bolts (50) are sealed against looseness. Always replace old ones with new ones when they are removed. Tighten the hex. Socket bolts with torque of 2.8-3.0 Nm [0.28-0.3 kgf·m].
- 6) Mount the balancer on a fitting.  
Refer to Chapter 3-1 "Balancer Installation".
- 7) Attach the tool/device to bottom Hook, and release the drum lock.

**⚠ WARNING**  
Never release the drum lock before attaching the tool/device. If released, Wire rope will snap back and could cause personal injury.

# Operating Instructions

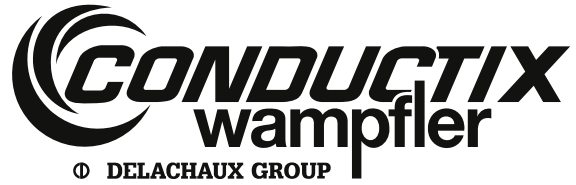

## Spring Balancer EWF-9 to EWF-70

BAL0400-1014a-US

### 10. 部品表 / PARTS LIST EWF-9, EWF-15

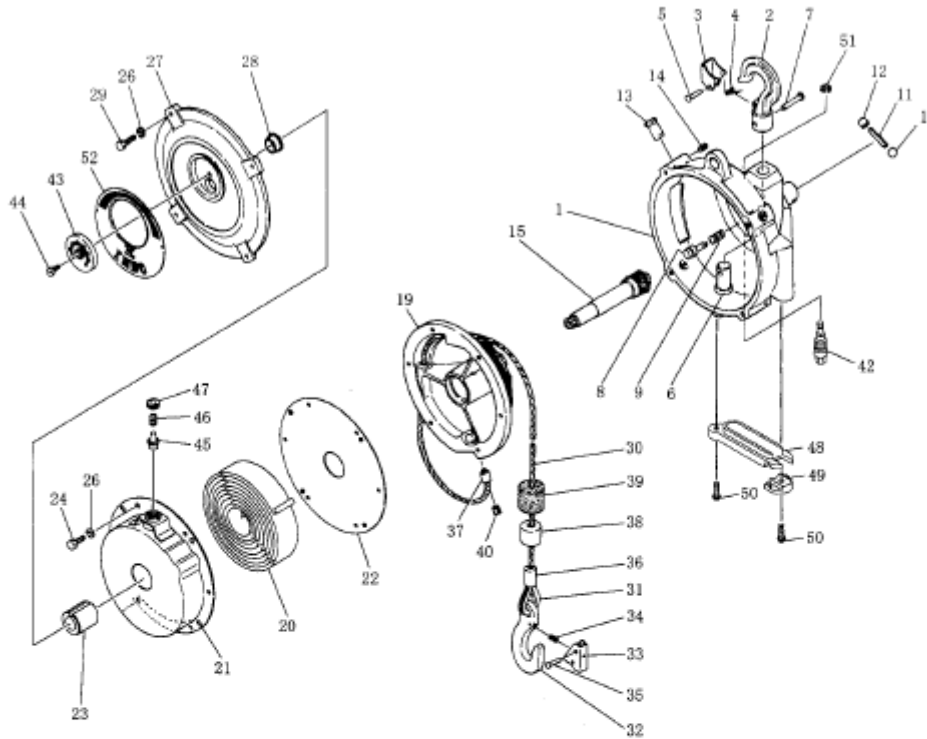

照合番号 Ref.No.	部品番号 Part No.	部品名称	個数/Quantity		Description
			EWF-9	EWF-15	
-	LBP001097	ケース部1式	1	1	Casing assembly
1	P2B100131	-ケース	1	1	-Casing
-	LBP000262	-フック1式	1	1	--Hook complete
2	---	--フック	1	1	--Hook
-	LBP000263	--外止め1式	1	1	--Latch set
3	---	---外止め	1	1	---Latch
4	---	---スプリング	1	1	---Spring
5	---	---丸リベット	1	1	---Rivet
6	---	--シャフト	1	1	--Shaft
7	---	--丸リベット	1	1	--Rivet
8	P2B400347	-ピン	1	1	-Pin
9	P2B400081	-スプリング	1	1	-Spring
11	P2B400224a	-スプリングピン	1	1	-Spring pin
12	P2B400348a	-キャップ	2	2	-Cap
13	P2B400044a	-ピン	3	3	-Pin
14	P2B400041a	-六角穴付止ネジ	3	3	-Set screw
15	P2B300160	スピンドル	1	1	Spindle
19	P2B100045	ドラム	1	1	Drum

照合番号 Ref.No.	部品番号 Part No.	部品名称	個数/Quantity		Description
			EWF-9	EWF-15	
-	LBP000596a	スプリング部1式	1	-	Spring assembly
-	LBP000597a	スプリング部1式	-	1	Spring assembly
20	---	-スプリング	1	-	-Spring
20	---	-スプリング	-	1	-Spring
21	---	-スプリングケース	1	1	-Spring case
-	LBP000271	-安全ピン1式	1	1	-Safety pin set
45	---	--安全ピン	1	1	--Safety pin
46	---	--スプリング	1	1	--Spring
47	---	--スクリュー	1	1	--Screw
22	---	-カバー	1	1	-Cover
23	P2B300163a	ブッシュ	1	1	Bushing
24	KA00120510	六角ボルト	4	4	Hex. head bolt
26	KA31120500	バネ座金	7	7	Spring washer
-	LBP000264	カバー1式	1	1	Cover complete
27	---	-カバー	1	1	-Cover
28	---	-ブッシュ	1	1	-Bushing
29	KA00120520	六角ボルト	3	3	Hex. head bolt
-	LBP000136	ワイヤロープ1式	1	1	Wire rope assembly
30	---	-ワイヤロープ	1	1	-Wire rope
31	---	-シンブル	1	1	-Thimble
-	LBP000021	-フック1式	1	1	-Hook complete
32	---	--フック	1	1	--Hook
-	LBP000270	--外止メ1式	1	1	--Latch set
33	---	---外止メ	1	1	---Latch
34	---	---スプリング	1	1	---Spring
35	---	---丸リベット	1	1	---Rivet
36	---	-ロック管	1	1	-Lock tube
37	---	-ロック管	1	1	-Lock tube
38	P2B400150a	-カラー	1	1	-Collar
39	P2B400147	-緩衝ゴム	1	1	-Buffer
40	P2H400007	プラグ	1	1	Plug
-	LBP001096	ワイヤガイド1式	1	1	Wire guide set
48	---	-ワイヤガイド	1	1	-Wire guide
49	---	-ワイヤガイド	1	1	-Wire guide
50	P2B401213b	-六角穴付ボタンボルト	2	2	-Hex. socket button bolt
42	P2B300062b	ウォーム	1	1	Worm
43	P2B300165	ゲージ	1	-	Gauge
43	P2B300166	ゲージ	-	1	Gauge
44	P2B400165a	スクリュー	1	1	Screw
51	KA40310050	E形止メ輪	1	1	Retaining ring
52	P2B300806	ネームプレート	1	-	Name plate
52	P2B300807	ネームプレート	-	1	Name plate

ご注意) ご注文の際には、部品番号、部品名称および製品の型式を指定してください。  
 尚、部品番号のない部品は個々に供給できません。  
 セット又は1式でご購入ください。

NOTE) When placing an order, clearly specify the product model, part number and description.  
 Parts without a part number cannot be supplied respectively.  
 Please purchase a set or complete unit.

10. 部品表 / PARTS LIST EWF-22, EWF-30

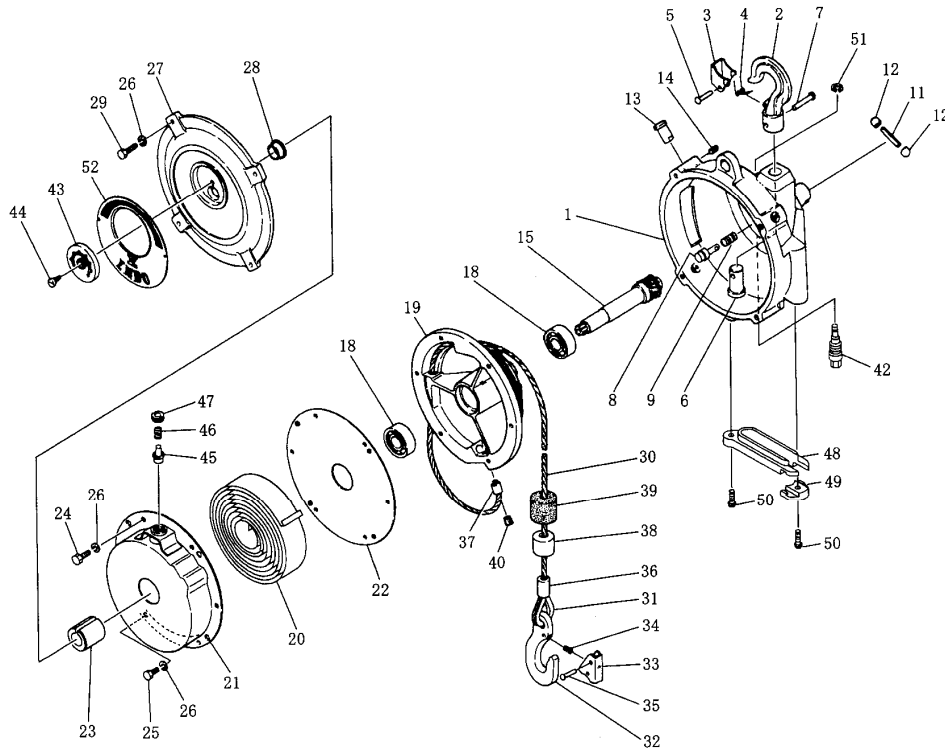

照合番号 Ref.No.	部品番号 Part No.	部品名称	個数/Quantity		Description
			EWF-22	EWF-30	
-	LBP001015	ケース部1式	1	1	Casing assembly
1	P2B100125a	ケース	1	1	-Casing
-	LBP000215	-フック1式	1	1	-Hook complete
2	-	--フック	1	1	--Hook
-	LBP000216	--外止めメ1式	1	1	--Latch set
3	-	---外止めメ	1	1	---Latch
4	-	----スプリング	1	1	----Spring
5	-	----丸リベット	1	1	----Rivet
6	-	--シャフト	1	1	--Shaft
7	-	--丸リベット	1	1	--Rivet
8	P2B400358	-ピン	1	1	-Pin
9	P2B400082	-スプリング	1	1	-Spring
11	P2B400225	-スプリングピン	1	1	-Spring pin
12	P2B400359	-キャップ	2	2	-Cap
13	P2B400045	-ピン	4	4	-Pin
14	P2B400042	-六角穴付止ネジ	4	4	-Set screw
15	P2B300167	スピンドル	1	1	Spindle
18	KA60103040	ボールベアリング	2	2	Ball bearing
19	P2B100047a	ドラム	1	1	Drum

照合番号 Ref.No.	部品番号 Part No.	部品名称	個数/Quantity		Description
			EWf-22	EWf-30	
-	LBP000598	スプリング部1式	1	-	Spring assembly
-	LBP000599	スプリング部1式	-	1	Spring assembly
20	---	-スプリング	1	-	-Spring
20	---	-スプリング	-	1	-Spring
21	---	-スプリングケース	1	1	-Spring case
-	LBP000225	-安全ピン1式	1	1	-Safety pin set
45	---	--安全ピン	1	1	--Safety pin
46	---	--スプリング	1	1	--Spring
47	---	--スクリュー	1	1	--Screw
22	---	-カバー	1	1	-Cover
23	P2B300194	ブッシュ	1	1	Bushing
24	KA00120610	六角ボルト	5	5	Hex.head bolt
25	P2B401234	六角ボルト	1	1	Hex.head bolt
26	KA31120600	バネ座金	10	10	Spring washer
-	LBP000265	カバー1式	1	1	Cover complete
27	---	-カバー	1	1	-Cover
28	---	-ブッシュ	1	1	-Bushing
29	KA00120620	六角ボルト	4	4	Hex.head bolt
-	LBP000139	ワイヤロープ1式	1	1	Wire rope assembly
30	---	-ワイヤロープ	1	1	-Wire rope
31	---	-シンブル	1	1	-Thimble
-	LBP000008	-フック1式	1	1	-Hook complete
32	---	--フック	1	1	--Hook
-	LBP000224	--外止メ1式	1	1	--Latch set
33	---	---外止メ	1	1	---Latch
34	---	---スプリング	1	1	---Spring
35	---	---丸リベット	1	1	---Rivet
36	---	-ロック管	1	1	-Lock tube
37	---	-ロック管	1	1	-Lock tube
38	P2B400151a	-カラー	1	1	-Collar
39	P2B400148	-緩衝ゴム	1	1	-Buffer
40	P2B400179	プラグ	1	1	Plug
-	LBP001021	ワイヤガイド1式	1	1	Wire guide set
48	---	-ワイヤガイド	1	1	-Wire guide
49	---	-ワイヤガイド	1	1	-Wire guide
50	P2B401213	-六角穴付ボタンボルト	2	2	-Hex.socket button bolt
42	P2B300062b	ウォーム	1	1	Worm
43	P2B300196	ゲージ	1	-	Gauge
43	P2B300197	ゲージ	-	1	Gauge
44	P2B400165a	スクリュー	1	1	Screw
51	KA40310050	E形止メ輪	1	1	Retaining ring
52	P2B300734	ネームプレート	1	-	Name plate
52	P2B300735	ネームプレート	-	1	Name plate

ご注意) ご注文の際には、部品番号、部品名称および製品の型式を指定してください。  
 尚、部品番号のない部品は個々に供給できません。  
 セット又は1式でご購入ください。

NOTE) When placing an order, clearly specify the product model, part number and description.  
 Parts without a part number cannot be supplied respectively.  
 Please purchase a set or complete unit.

# Operating Instructions

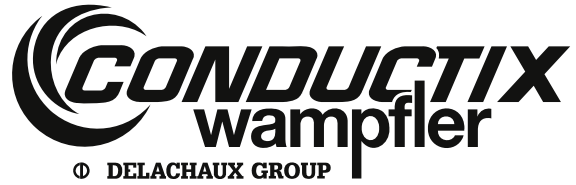

## Spring Balancer EWF-9 to EWF-70

BAL0400-1014a-US

### 10.部品表 / PARTS LIST EWF-40,EWF-50

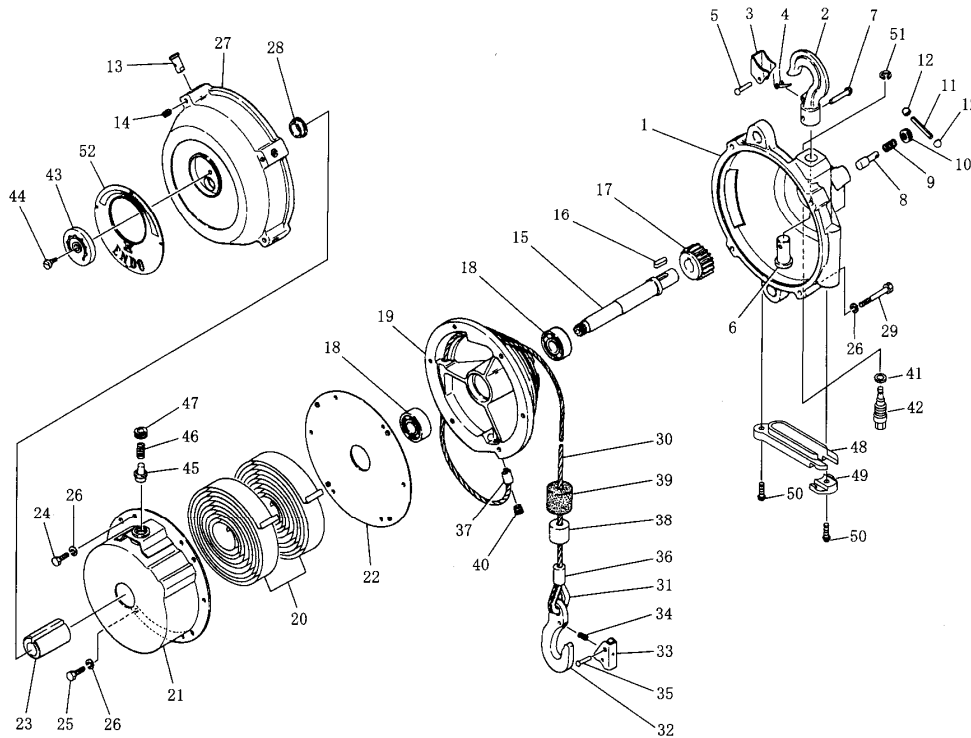

照合番号 Ref.No.	部品番号 Part No.	部 品 名 称	個数/Quantity		Description
			EWF-40	EWF-50	
-	LBP001016	ケース部1式	1	1	Casing assembly
1	P2B100128	-ケース	1	1	-Casing
-	LBP000215	-フック1式	1	1	-Hook complete
2	-	--フック	1	1	--Hook
-	LBP000216	--外止メ1式	1	1	--Latch set
3	-	----外止メ	1	1	----Latch
4	-	----スプリング	1	1	----Spring
5	-	----丸リベット	1	1	----Rivet
6	-	--シャフト	1	1	--Shaft
7	-	--丸リベット	1	1	--Rivet
8	P2B400380	-ピン	1	1	-Pin
9	P2B400082	-スプリング	1	1	-Spring
10	P2B400249	-スクリュー	1	1	-Screw
11	P2B400225	-スプリングピン	1	1	-Spring pin
12	P2B400359	-キャップ	2	2	-Cap
15	P2B300198	スピンドル	1	1	Spindle
16	P2B400164	キー	1	1	Key
17	P2B300051	ウォームホイール	1	1	Worm wheel
18	KA60103040	ボールベアリング	2	2	Ball bearing
19	P2B100047a	ドラム	1	1	Drum

照合番号 Ref.No.	部品番号 Part No.	部 品 名 称	個数 / Quantity		Description
			EWF-40	EWF-50	
-	LBP000600	スプリング部1式	1	-	Spring assembly
-	LBP000601	スプリング部1式	-	1	Spring assembly
20	---	-スプリング	2	-	-Spring
20	---	-スプリング	-	2	-Spring
21	---	-スプリングケース	1	1	-Spring case
-	LBP000272	-安全ピン1式	1	1	-Safety pin set
45	---	--安全ピン	1	1	--Safety pin
46	---	--スプリング	1	1	--Spring
47	---	--スクリュー	1	1	--Screw
22	---	-カバー	1	1	-Cover
23	P2B300203	ブッシュ	1	1	Bushing
24	KA00120610	六角ボルト	5	5	Hex.head bolt
25	P2B401234	六角ボルト	1	1	Hex.head bolt
26	KA31120600	バネ座金	10	10	Spring washer
-	LBP001019	カバー部1式	1	1	Cover assembly
-	LBP001017	-カバー1式	1	1	-Cover complete
27	---	--カバー	1	1	--Cover
28	---	--ブッシュ	1	1	--Bushing
13	P2B400045	-ピン	4	4	-Pin
14	P2B400042	-六角穴付止ネジ	4	4	-Set screw
29	KA00120640	六角ボルト	4	4	Hex.head bolt
-	LBP000139	ワイヤロープ1式	1	1	Wire rope assembly
30	---	-ワイヤロープ	1	1	-Wire rope
31	---	-シンブル	1	1	-Thimble
-	LBP000008	-フック1式	1	1	-Hook complete
32	---	--フック	1	1	--Hook
-	LBP000224	--外止メ1式	1	1	--Latch set
33	---	---外止メ	1	1	---Latch
34	---	---スプリング	1	1	---Spring
35	---	---丸リベット	1	1	---Rivet
36	---	-ロック管	1	1	-Lock tube
37	---	-ロック管	1	1	-Lock tube
38	P2B400151a	-カラー	1	1	-Collar
39	P2B400148	-緩衝ゴム	1	1	-Buffer
40	P2B400179	プラグ	1	1	Plug
-	LBP001021	ワイヤガイド1式	1	1	Wire guide set
48	---	-ワイヤガイド	1	1	-Wire guide
49	---	-ワイヤガイド	1	1	-Wire guide
50	P2B401213	-六角穴付ボタンボルト	2	2	-Hex.socket button bolt
41	P2B400163	ワッシャ	1	1	Washer
42	P2B300063a	ウォーム	1	1	Worm
43	P2B300205	ゲージ	1	-	Gauge
43	P2B300206	ゲージ	-	1	Gauge
44	P2B400165a	スクリュー	1	1	Screw
51	KA40310060	E形止メ輪	1	1	Retaining ring
52	P2B300738	ネームプレート	1	-	Name plate
52	P2B300739	ネームプレート	-	1	Name plate

ご注意) ご注文の際には、部品番号、部品名称および製品の型式を指定してください。  
尚、部品番号のない部品は個々に供給できません。  
セット又は1式でご購入ください。

NOTE) When placing an order, clearly specify the product model, part number and description.  
Parts without a part number cannot be supplied respectively.  
Please purchase a set or complete unit.

10. 部品表 / PARTS LIST EWF-60, EWF-70

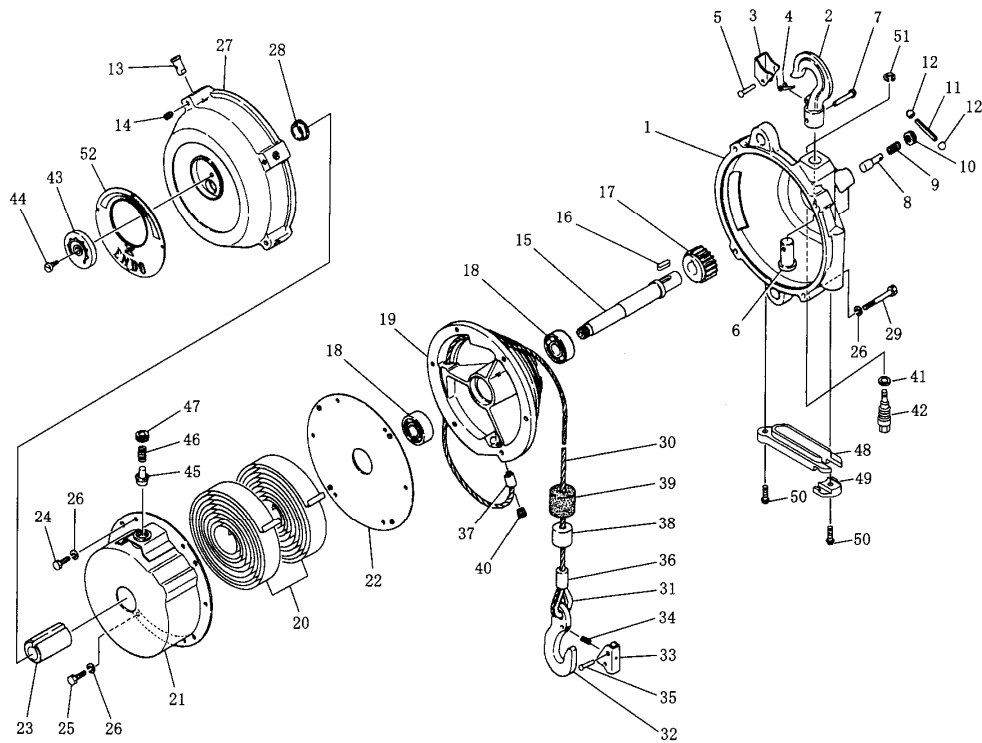

照合番号 Ref.No.	部品番号 Part No.	部品名称	個数 / Quantity		Description
			EWF-60	EWF-70	
-	LBP001016	ケース部1式	1	1	Casing assembly
1	P2B100128	-ケース	1	1	-Casing
-	LBP000215	-フック1式	1	1	-Hook complete
2	---	---フック	1	1	---Hook
-	LBP000216	---外止め1式	1	1	---Latch set
3	---	---外止め	1	1	---Latch
4	---	---スプリング	1	1	---Spring
5	---	---丸リベット	1	1	---Rivet
6	---	---シャフト	1	1	---Shaft
7	---	---丸リベット	1	1	---Rivet
8	P2B400380	-ピン	1	1	-Pin
9	P2B400082	-スプリング	1	1	-Spring
10	P2B400249	-スクリュー	1	1	-Screw
11	P2B400225	-スプリングピン	1	1	-Spring pin
12	P2B400359	-キャップ	2	2	-Cap
15	P2B300199	スピンドル	1	1	Spindle
16	P2B400164	キー	1	1	Key
17	P2B300051	ウォームホイール	1	1	Worm wheel
18	KA60103040	ボールベアリング	2	2	Ball bearing
19	P2B100047a	ドラム	1	1	Drum

照合番号 Ref.No.	部品番号 Part No.	部 品 名 称	個数/Quantity		Description
			EWF-60	EWF-70	
-	LBP000602	スプリング部1式	1	-	Spring assembly
-	LBP000603	スプリング部1式	-	1	Spring assembly
20	---	-スプリング	2	-	-Spring
20	---	-スプリング	-	2	-Spring
21	---	-スプリングケース	1	1	-Spring case
-	LBP000272	-安全ピン1式	1	1	-Safety pin set
45	---	--安全ピン	1	1	--Safety pin
46	---	--スプリング	1	1	--Spring
47	---	--スクリュー	1	1	--Screw
22	---	-カバー	1	1	-Cover
23	P2B300204	ブッシュ	1	1	Bushing
24	KA00120610	六角ボルト	5	5	Hex.head bolt
25	P2B401234	六角ボルト	1	1	Hex.head bolt
26	KA31120600	バネ座金	10	10	Spring washer
-	LBP001020	カバー部1式	1	1	Cover assembly
-	LBP001018	-カバー1式	1	1	-Cover complete
27	---	--カバー	1	1	--Cover
28	---	--ブッシュ	1	1	--Bushing
13	P2B400045	-ピン	4	4	-Pin
14	P2B400042	-六角穴付止ネジ	4	4	-Set screw
29	KA00120640	六角ボルト	4	4	Hex.head bolt
-	LBP000139	ワイヤロープ1式	1	1	Wire rope assembly
30	---	-ワイヤロープ	1	1	-Wire rope
31	---	-シンブル	1	1	-Thimble
-	LBP000008	-フック1式	1	1	-Hook complete
32	---	--フック	1	1	--Hook
-	LBP000224	--外止メ1式	1	1	--Latch set
33	---	---外止メ	1	1	---Latch
34	---	---スプリング	1	1	---Spring
35	---	---丸リベット	1	1	---Rivet
36	---	-ロック管	1	1	-Lock tube
37	---	-ロック管	1	1	-Lock tube
38	P2B400151a	-カラー	1	1	-Collar
39	P2B400148	-緩衝ゴム	1	1	-Buffer
40	P2B400179	プラグ	1	1	Plug
-	LBP001021	ワイヤガイド1式	1	1	Wire guide set
48	---	-ワイヤガイド	1	1	-Wire guide
49	---	-ワイヤガイド	1	1	-Wire guide
50	P2B401213	-六角穴付ボタンボルト	2	2	-Hex.socket button bolt
41	P2B400163	ワッシャ	1	1	Washer
42	P2B300063a	ウォーム	1	1	Worm
43	P2B300207	ゲージ	1	-	Gauge
43	P2B300208	ゲージ	-	1	Gauge
44	P2B400165a	スクリュー	1	1	Screw
51	KA40310060	E形止メ輪	1	1	Retaining ring
52	P2B300740	ネームプレート	1	-	Name plate
52	P2B300741	ネームプレート	-	1	Name plate

ご注意) ご注文の際には、部品番号、部品名称および製品の型式を指定してください。  
 尚、部品番号のない部品は個々に供給できません。  
 セット又は1式でご購入ください。

NOTE) When placing an order, clearly specify the product model, part number and description.  
 Parts without a part number cannot be supplied respectively.  
 Please purchase a set or complete unit.