

Installation, Operation, & Maintenance Manual

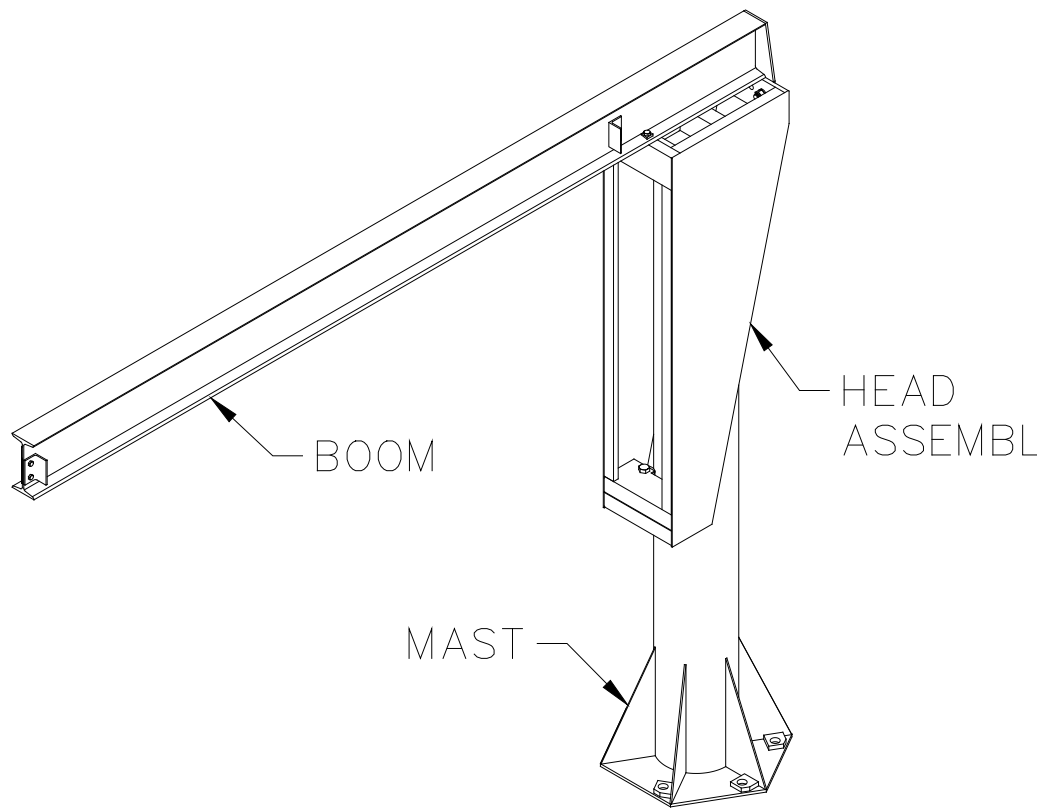

**IMPORTANT!
DO NOT DESTROY**

Free Standing Jib Crane

Gorbel® Customer Order No. / Serial No. _____

Gorbel® Dealer _____

Date _____
Month Year

Distributed by Ergonomic Partners
Sales@ErgonomicPartners.com
www.ErgonomicPartners.com
Tel: (314) 884-8884

TABLE OF CONTENTS

Introduction.....	1
Installation	
Step 1 - Pre-assembly.....	2
Step 2A - FS300 (FREE STANDING).....	3-4
Step 2B - FS350 (INSERT MOUNTED).....	5-6
Step 2C - FS350S (SLEEVE MOUNTED).....	7-8
Step 2D - FS300NP (FREE STANDING FOUNDATIONLESS).....	9
Step 3 - Plumbing Mast.....	10
Step 4 - Head Installation.....	11
Step 5 - Boom Installation.....	12
Step 6 - Endstop/Tagline Installation.....	13
Step 7 - Optional Accessories.....	14-15
Step 8 - Final Steps.....	15
Crane Operator Instructions.....	16
General Safety Suggestions.....	16
Limited Warranty.....	17
Inspection and Maintenance Schedule.....	18

Questions? Concerns? Comments? Please call (800) 821-0086 (US and Canada) or (585) 924-6262 (outside US).

INTRODUCTION

Thank you for choosing a Gorbel® Free Standing Jib Crane to solve your material handling needs. The innovative design and heavy duty construction of a Gorbel® Free Standing Jib Crane will provide a superior quality product that will offer years of long term value. All Gorbel® cranes are pre-engineered for powered hoist operation. The hoist weight allowance is 15% of the crane capacity (for example, a crane rated for 1000 pounds allows for a 1000-pound live load plus 150 pounds for the weight of the hoist). There is also an allowance of 25% of the crane capacity for impact caused by hoist use. Gorbel® Free Standing Jib Cranes will provide many years of dependable service by following the installation and maintenance procedures described herein.

Dimensions contained in this installation manual are for reference only and may differ for your particular application. Please refer to the enclosed General Arrangement Drawing for actual dimensions.

Normal safety precautions: These include, but are not limited to:

- Checking for obstructions in crane rotation
- Checking that all bolts are tight and have lockwashers
- Making sure that endstop is in place
- Making sure that festooning cannot be snagged or pinched

For additional safety precautions see page 16.

WARNING

Only competent erection personnel familiar with standard fabrication practices should be employed to assemble these cranes because of the necessity of properly interpreting these instructions. Gorbel is not responsible for the quality of workmanship employed in the installation of a crane according to these instructions. Contact Gorbel, Inc., at 600 Fishers Run, P.O. Box 593, Fishers, New York 14453-0593, 1-585-924-6262, for additional information if necessary.

WARNING

Equipment described herein is not designed for, and should not be used for, lifting, supporting or transporting humans. Failure to comply with any one of the limitations noted herein can result in serious bodily injury and/or property damage. Check State and Local regulations for any additional requirements.

WARNING

Consult a qualified structural engineer to determine if your support structure is adequate to support the loads generated by anchor bolt force, overturning moment, or axial load of your crane.

WARNING

Crane cannot be utilized as a ground: A separate ground wire is required. For example, systems with 3 phase power require 3 conductors plus one ground wire.

WARNING

Reference American Institute of Steel Construction (AISC) Manual of Steel Construction (9th edition), Part 5, Specification for Structural Joints using ASTM A325 or A490 Bolts (section 8.d.2) for proper procedures to follow when using any torque tightening method.

WARNING

Do not field modify crane in any way. Any modifications without the written consent of Gorbel, Inc. will void warranty.

INSTALLATION

STEP 1 - PRE-ASSEMBLY

➤ **TIP:** Packing list can be found in plastic pocket attached to hardware box.
 General Arrangement Drawing can be found inserted in this installation manual.

- 1.1 Read entire manual **before** installing the crane.
- 1.2 Check packing list to ensure no parts have been lost prior to initiating assembly of crane.
- 1.3 Tools and materials typically needed to assemble crane:
 - Torque wrench
 - Ladders/man lifts
 - Hand tools
 - Leveling tools (plumb bob, plumb fixture-pg. 10)
 - Allen wrenches
 - Lifting device to lift heavy masts and booms
 - Steel shims
 - Grout (Non-Shrink Precision Grout)
 - Base Plate Template
 - Anchor Bolts (grade 5 or better)
- 1.4 Identify crane type:

WARNING

Consult a qualified structural engineer to determine that your support structure is adequate to support the loads generated by anchor bolt force, overturning moment, or axial load of your crane.

If your crane looks like:

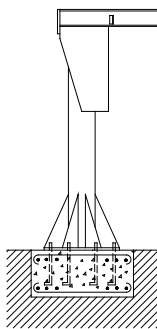

Go to page 3.

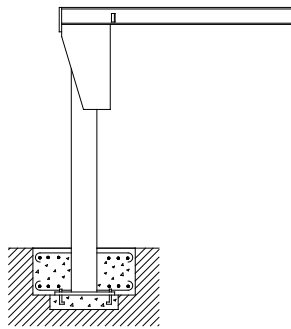

Go to page 5.

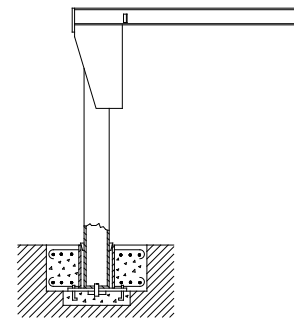

Go to page 7.

Bolt Dia.	Torque
1/4"-20	6 ft.-lbs.
3/8"-16	20 ft.-lbs.
1/2"-13	50 ft.-lbs.
5/8"-11	95 ft.-lbs.
3/4"-10	175 ft.-lbs.
7/8"-9	300 ft.-lbs.

Chart 1A. Torque Chart.

STANDARD BOOM DATA		
Boom Height (W)	Beam Size	Flange Width (in)
6"	S6@12.5#/ft.	3-3/8"
8"	W8@18.4#/ft.	5-1/4"
10"	S10@25.4#/ft.	4-5/8"
12"	S12@31.8#/ft.	5"
16"	W16@45#/ft.	7"
18"	W18@50#/ft.	7-1/2"
21"	W21@62#/ft.	8-1/4"
24"	W24@84#/ft.	9"

Chart 1B. Boom data.

E	BEARING PART NUMBERS			
	Top Pivot		Trunnion Roller	
	Cup	Cone	Cup	Cone
8	08251	08250	03260A	03260A
12	08251	08250	08248	08249
14	08253	08252	08248	08249
16	08253	08252	08248	08249
18	08255	08254	08248	08249
20	08255	08254	08248	08249
24	08265	08264	08248	08249
30	08265	08264	08248	08249

Chart 1C. Bearing Part Numbers.

STEP 2A - FS300 (FREE STANDING)

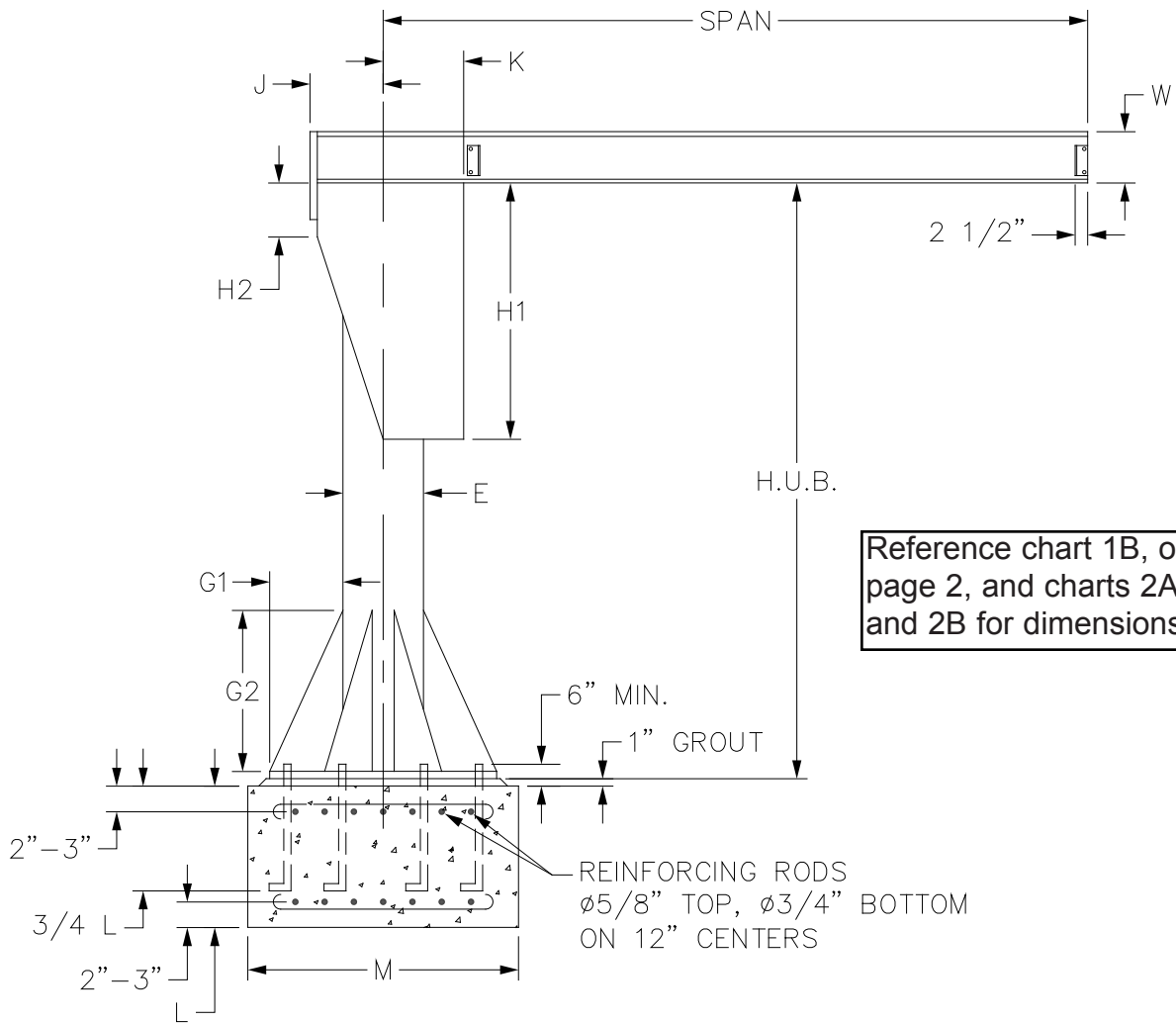

Reference chart 1B, on page 2, and charts 2A and 2B for dimensions.

Diagram 2A. FS300

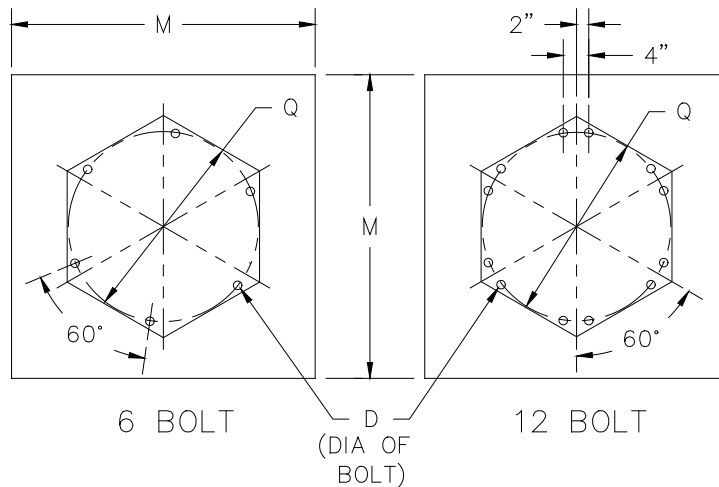

Diagram 2B. Base Bolt Pattern

STEP 2A - FS300 (FREE STANDING) (CONTINUED)

FS300 BASE PLATE MOUNTED

2.1 Pour the footing, according to the footing dimensions in **diagrams 2A and 2B**, page 3, and **charts 2A and 2B**, with the anchor bolts (J-bolts) in place. There should be between 4" and 6" of anchor bolt exposed above the floor level.

PIPE SIZE	DIMENSIONS (IN.)						ANCHOR BOLT PATTERN		
	E	G1	G2	J	K	H1	H2	QTY.	D
8	10	20	10-3/8	10	46-3/4	4	6	1.00	24
12	8-1/2	20	12-7/8	12-1/2	71-3/4	6	6	1.25	24
14	11	22	15-3/8	15	72	8	6	1.25	30
16	13	26	17-3/8	17	72	8	12	1.25	36
18	15	30	17-3/8	17	72	9	12	1.25	42
20	17	34	17-7/8	17-1/2	72	10	12	1.25	48
24	18	36	22-7/8	22-1/2	77	12	12	1.25	54
30	18	36	25-3/8	25	84	12	12	1.25	60

Note: Jib crane foundation requirements are based on a soil pressure of 2500 lbs. per square foot. Concrete recommended for jib crane foundation is 3000 lbs. per square inch of compressive force.

Chart 2A. Crane Dimensions

Note: Foundation/concrete must cure 7 days prior to mast installation. Foundation/concrete must cure 28 days prior to using crane to full capacity.

2.2 Once the concrete has cured, cover the base plate area with one (1") inch of grout.

Note: Grout is required to ensure the jib base plate has full contact support to the floor/footing. Shimming/leveling nuts under the base plate are acceptable methods that would aid plumbing of the mast assembly prior to setting the jib mast on the grout bed (shimming/leveling nuts by others). Grout must be a non-shrink, high compressive machinery type grout.

2.3 Set the mast into place and make sure the base plate is completely seated in the grout.

2.4 Plumb mast following the plumbing procedure in Step 3, page 10.

2.5 Once mast is plumb and grout has cured, tighten anchor bolts per manufacturer's specifications.

Note: If Gorbel is the supplier of the anchor bolts, tighten to full compression of the lockwasher.

2.6 Proceed to Step 4, page 11.

STANDARD FOOTING REQUIREMENTS			
Capacity Tons	Span (ft.)	Depth (ft.)	
		M	L
1/4	8-13	4	3
	14-20	4	4
1/2	8-12	4	4
	13-20	5	4
1	8-10	5	4
	11-15	6	4
	16-20	7	4
1-1/2	8-12	6	4
	13-15	7	4
	16-20	8	4
2	8-11	6	4
	12-15	7	4
	16-20	8	4
3	8-16	8	4
	17-20	9	4
4	8-13	8	4
	14-20	10	4
5	8-14	9	4
	15-18	10	4
	19-20	10	5

Chart 2B. Foundation Depth

STEP 2B - FS350 (INSERT MOUNTED)

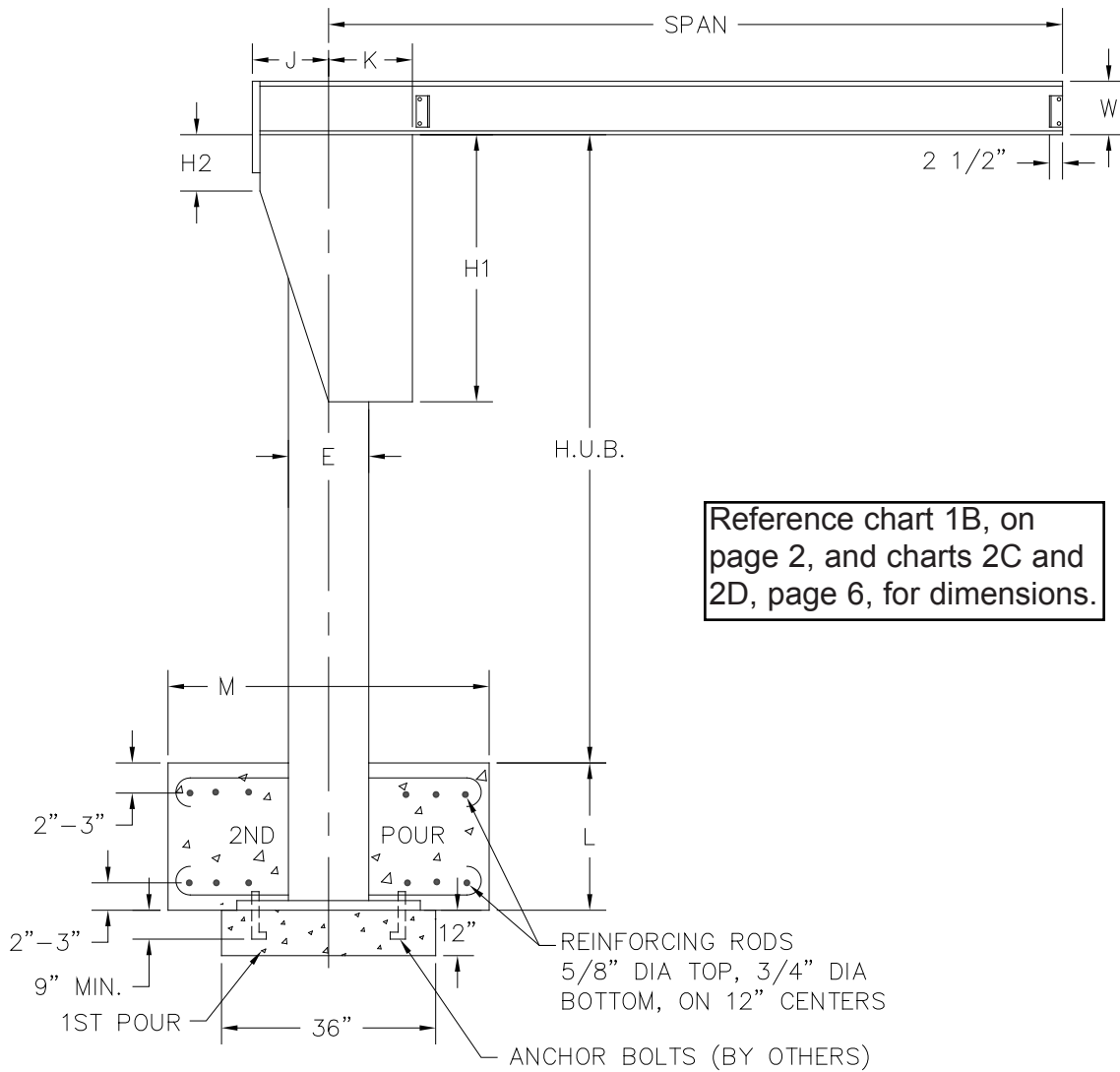

Reference chart 1B, on page 2, and charts 2C and 2D, page 6, for dimensions.

Diagram 2C. FS350

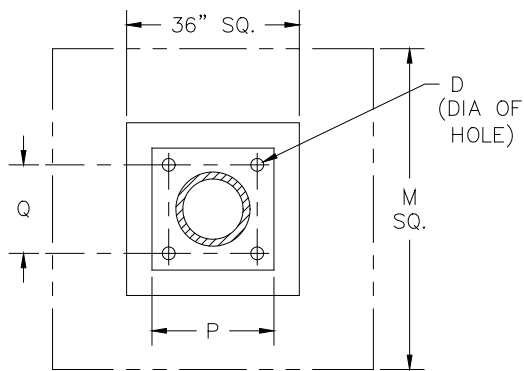

Diagram 2D. Base Bolt Pattern

STEP 2B - FS350 (INSERT MOUNTED) (CONTINUED)

FS350 INSERT MOUNTED

2.7 Pour the first footing, according to the footing dimensions in **diagrams 2C and 2D**, page 5, and **charts 2C and 2D**, with the anchor bolts (J-bolts) (by others) in place.

Note: Jib crane foundation requirements are based on a soil pressure of 2500 lbs. per square foot. Concrete recommended for jib crane foundation is 3000 lbs. per square inch of compressive force.

Note: Foundation/concrete must cure 7 days prior to mast installation. Foundation/concrete must cure 28 days prior to using crane to full capacity.

2.8 Once the concrete has cured, set the mast into place.

2.9 Plumb mast following the plumbing procedure in Step 3, page 10. Use grout and/or shims according to installer's recommendations.

2.10 Once mast is plumb, tighten anchor bolts per manufacturer's specifications.

2.11 Make the second pour according to the footing dimensions in **diagram 2C**, page 5, and chart 2D.

2.12 Proceed to Step 4, page 11.

PIPE SIZE	DIMENSIONS (IN.)				ANCHOR BOLT PATTERN		
	E	J	K	H1	H2	D	P
8	10-3/8	10	46-3/4	4	13/16	11	8
12	12-7/8	12-1/2	71-3/4	6	13/16	15	12
14	15-3/8	15	72	8	13/16	17	14
16	17-3/8	17	72	8	13/16	19	16
18	17-3/8	17	72	9	13/16	21	18
20	17-7/8	17-1/2	72	10	13/16	23	20
24	22-7/8	22-1/2	77	12	13/16	27	24
30	25-3/8	25	84	12	13/16	33	30

Chart 2C. Crane Dimensions

STANDARD FOOTING REQUIREMENTS			
Capacity Tons	Span (ft.)	Width (ft.)	
		M	L
1/4	8-13	4	3
	14-20	4	4
1/2	8-12	4	4
	13-20	5	4
1	8-10	5	4
	11-15	6	4
	16-20	7	4
1-1/2	8-12	6	4
	13-15	7	4
	16-20	8	4
2	8-11	6	4
	12-15	7	4
	16-20	8	4
3	8-16	8	4
	17-20	9	4
4	8-13	8	4
	14-20	10	4
5	8-14	9	4
	15-18	10	4
	19-20	10	5

Chart 2D. Foundation Depth

STEP 2C - FS350S (SLEEVE MOUNTED)

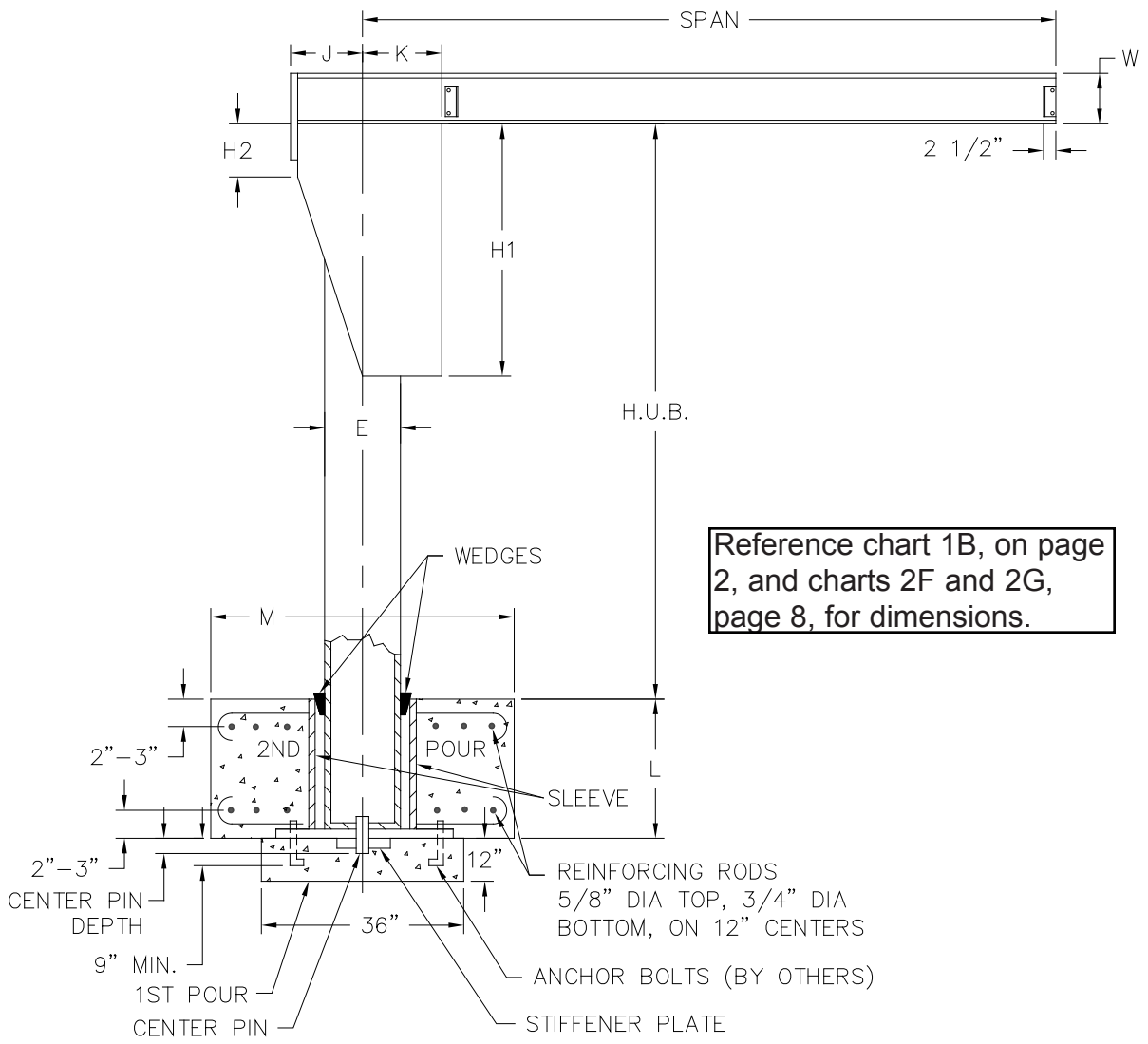

Reference chart 1B, on page 2, and charts 2F and 2G, page 8, for dimensions.

Diagram 2E. FS350S

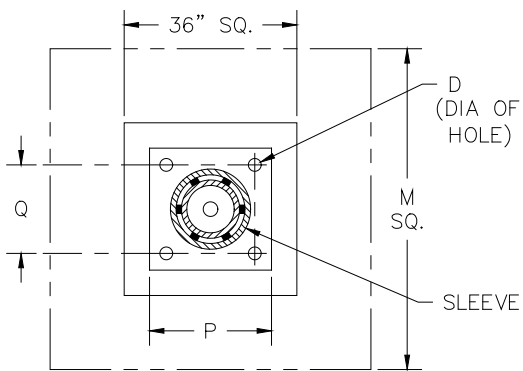

Diagram 2F. Base Bolt Pattern

Pipe Size (E)	Footing Depth (L)	Stiffener Plate Size (in. sq.)	Center Pin Depth (in.)
8	36	6	15/16
8	48	6	15/16
12	36	6	15/16
12	48	6	15/16
14	48	6	15/16
16	48	6	15/16
18	48	6	15/16
20	48	6	15/16
24	48	8	1-3/16
30	48	8	1-3/16
30	60	8	1-3/16

Chart 2E. Stiffener Plate and Center Pin Cut-Out Requirements

STEP 2C - FS350S (SLEEVE MOUNTED) (CONTINUED)

FS350S SLEEVE INSERT MOUNTED

2.13 Pour the first footing, according to the footing dimensions in **diagrams 2E and 2F**, page 7, and **charts 2F and 2G**, with the anchor bolts (J-bolts) (by others) in place. See **chart 2E** to calculate stiffener plate and center pin cut-out requirements.

Note: Jib crane foundation requirements are based on a soil pressure of 2500 lbs. per square foot.

Concrete recommended for jib crane foundation is 3000 lbs. per square inch of compressive force.

Note: Foundation/concrete must cure 7 days prior to mast installation. Foundation/concrete must cure 28 days prior to using crane to full capacity.

2.14 Once the concrete has set, set the sleeve in place (confirm sleeve size prior to setting) and tighten the anchor bolts, making sure the sleeve is plumb.

2.15 Make the second pour according to the footing dimensions in **diagram 2F**, page 7, and **chart 2G**.

2.16 When the second pour has cured, insert the mast inside the sleeve. Ensure that the center pin is fully inserted in the centering hole in the mast.

2.17 Using steel wedges (included) every 60°, plumb mast following the plumbing procedure in Step 3, page 10.

2.18 Once the mast is plumb, weld the steel wedges to the mast and sleeve to prevent any shifting of the mast.

PIPE SIZE	DIMENSIONS (IN.)				ANCHOR BOLT PATTERN		
	E	J	K	H1	H2	D	P
8	10-3/8	10	46-3/4	4	1	13	10
12	12-7/8	12-1/2	71-3/4	6	1	17	14
14	15-3/8	15	72	8	1	19	16
16	17-3/8	17	72	8	1	21	18
18	17-3/8	17	72	9	1	23	20
20	17-7/8	17-1/2	72	10	1	25	22
24	22-7/8	22-1/2	77	12	1	29	26
30	25-3/8	25	84	12	1	35	32

Chart 2F. Crane Dimensions

STANDARD FOOTING REQUIREMENTS			
Capacity Tons	Span (ft.)	Width (ft.)	
		M	L
1/4	8-13	4	3
	14-20	4	4
1/2	8-12	4	4
	13-20	5	4
1	8-10	5	4
	11-15	6	4
	16-20	7	4
1-1/2	8-12	6	4
	13-15	7	4
	16-20	8	4
2	8-11	6	4
	12-15	7	4
	16-20	8	4
3	8-16	8	4
	17-20	9	4
4	8-13	8	4
	14-20	10	4
5	8-14	9	4
	15-18	10	4
	19-20	10	5

Chart 2G. Foundation Depth

WARNING

All welds must meet American Welding Society (AWS) specification D1.1 using E70xx electrodes.

2.19 Proceed to Step 4, page 11.

STEP 2D - FS300NP6 (FREE STANDING FOUNDATIONLESS)

Hexagonal Base Plates for Foundationless Jibs

For jib cranes that can be mounted on a 6" foundation that is free from cracks, seams, expansion joints, and walls (*chart 2H*).

WARNING

Consult a qualified structural engineer if you deviate from the recommended dimensions provided in this manual. Gorbel Inc. is not responsible for any deviation from these foundation requirements.

2.20 A) Anchor bolts (by others) for **hexagonal** base plates must:

- be 1" in diameter (*diagram 2H*).

Note: Jib cranes that have an NP6 designation have a special design that is different than standard Free Standing Jib Cranes for poured foundations. The NP6 base plate stiffener allows for a 1" diameter anchor bolt as opposed to the standard base plate stiffener that allows for a 1-1/4" diameter anchor bolt. If you have a standard design FS Jib for a poured foundation refer to Step 2A. Contact Gorbel® Customer Service if you are unsure what style (NP6 or Standard) Free Standing Jib Crane you have.

- be embedded at least 4" into the floor, not to exceed 3/4 of foundation depth.

Note: A minimum 6" thick reinforced concrete floor is required.

- have **minimum** of two threads above nut after installation.

Note: Jib crane foundation requirements are based on soil pressure of 2500# per square foot. Concrete pressure recommended for jib crane foundation is 3000# per square inch of compressive force.

Note: Foundationless Free Standing Jib Cranes should be mounted to a shallow foundation, centered on a square foot area that is free from cracks, seams and walls mounted with chemical anchor bolts to withstand a minimum of 3470# of pull out force.

Note: Chemical (epoxy) anchor bolts are recommended because of their ability to withstand the vibrating loads caused by the hoist stopping and starting under load.

B) Drill holes in concrete floor using pre-drilled holes in base plate or *diagram 2H* as a guide (use drill bit size recommended by anchor bolt manufacturer).

C) Install anchor bolts (Grade 5 or better) and hardware (by others) according to the manufacturer's installation directions and requirements.

2.21 Set the mast into place and make sure the base plate is completely seated in the grout.

2.22 Plumb mast following the plumbing procedure in Step 3, page 10.

2.23 Once mast is plumb and grout has cured, tighten anchor bolts per manufacturer's specifications. Note: If Gorbel is the supplier of the anchor bolts, tighten to full compression of the lockwasher.

2.24 Proceed to Step 4, page 11.

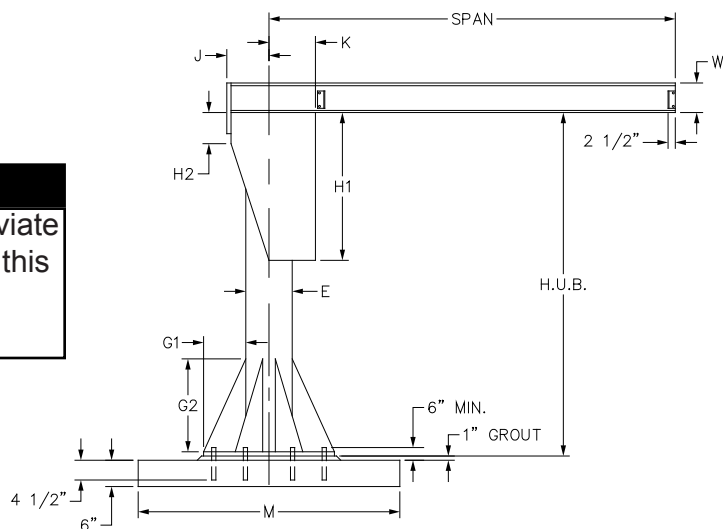

Diagram 2G. FS300NP6

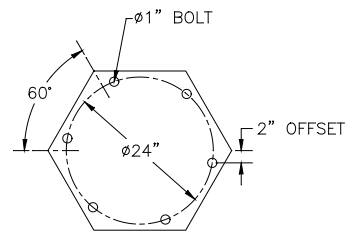

Diagram 2H. Base bolt pattern.

Capacity	Span	Foundation Size (sq. ft.)
1/4 ton	8' - 9'	5 x 5
	10' - 13'	6 x 6
1/2 ton	8' - 9'	6 x 6

Chart 2H. Distance of jib from cracks, seams, walls.

STEP 3 - PLUMBING MAST

WARNING

Mast must be plumb to prevent boom from drifting.

PLUMBING MAST

- 3.1 Drop plumb line (not included) from top of mast, using fixture (not included) or equivalent (*diagram 3A*).
 - 3.2 At point "A", one (1") inch below the top mast plate, set plumb line a distance of three (3") inches from the surface of the mast pipe (*diagram 3B*).
 - 3.3 At point "B", five (5') feet below point "A" (approximately where rollers will contact mast pipe), the distance between plumb line and the surface of the mast pipe should also be three (3") inches.
 - 3.4 Repeat steps 3.1 through 3.3 every 60° around mast to ensure mast is plumb throughout.
- Note:** Be sure to fasten plumb line securely to plumb fixture so that it will not move. Movement will result in an inaccurate plumb measurement.
- 3.5 Once mast is plumb and grout (FS300) has cured, fully tighten anchor bolt hardware.
 - 3.6 Verify mast is still plumb.

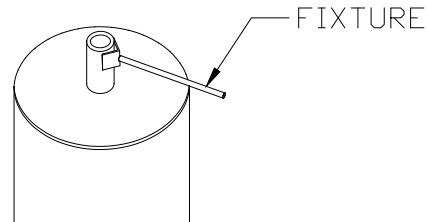

Diagram 3A. Plumbing fixture.

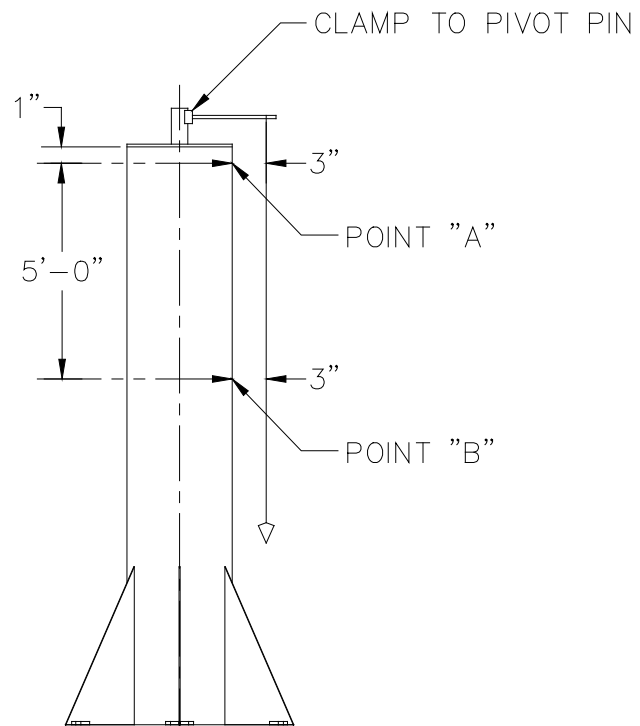

Diagram 3B. Plumbing the Mast

**DO NOT USE A
LEVEL TO
PLUMB MAST.**



STEP 4 - HEAD INSTALLATION

TIP: Trunnion rollers should have full face contact with mast pipe when properly installed.

- 4.1 Wipe protective grease coating off and/or remove tape from pivot pin.
- 4.2 Place and orient tapered roller bearing inner race (cone) on the mast pivot pin (*diagram 4A*).
- 4.3 Remove safety channel from head assembly if it is bolted into place.
- 4.4 Place the head on the mast. Install V-ring seal (shipped loose) over mast pivot pin and press against weight bearing frame. Secure head by

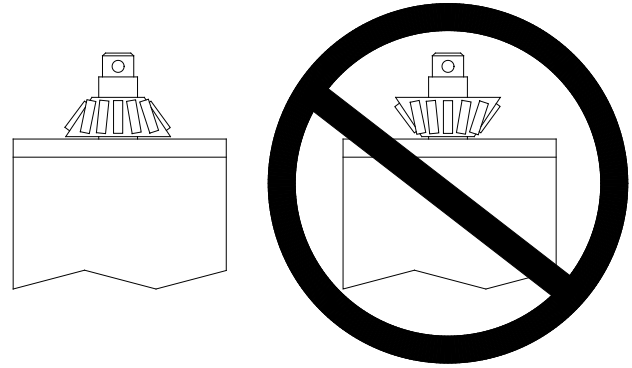

Diagram 4A. Bearing Orientation.

inserting the safety retaining pin into the hole located in the mast pivot pin. Ensure that the safety retaining pin is centered to within 1/16" inside of the mast pivot pin. Place 2 hose clamps (one on either side) over each end of the safety retaining pin and slide them inward until they come in contact with the mast pivot pin (*diagram 4B*). Tighten both hose clamps such that the safety retaining pin is locked into place without the ability to slide sideways. Also ensure that both hose clamps are identically oriented on the pin and, once tightened, ensure the clamp screws are facing downward.

Note: It is imperative that the safety retaining pin is installed in the "centered" position to avoid a possible interference with the threaded stud welded to the weight bearing frame.

- 4.5 Reinstall the safety channel into the head if removed in step 4.3.

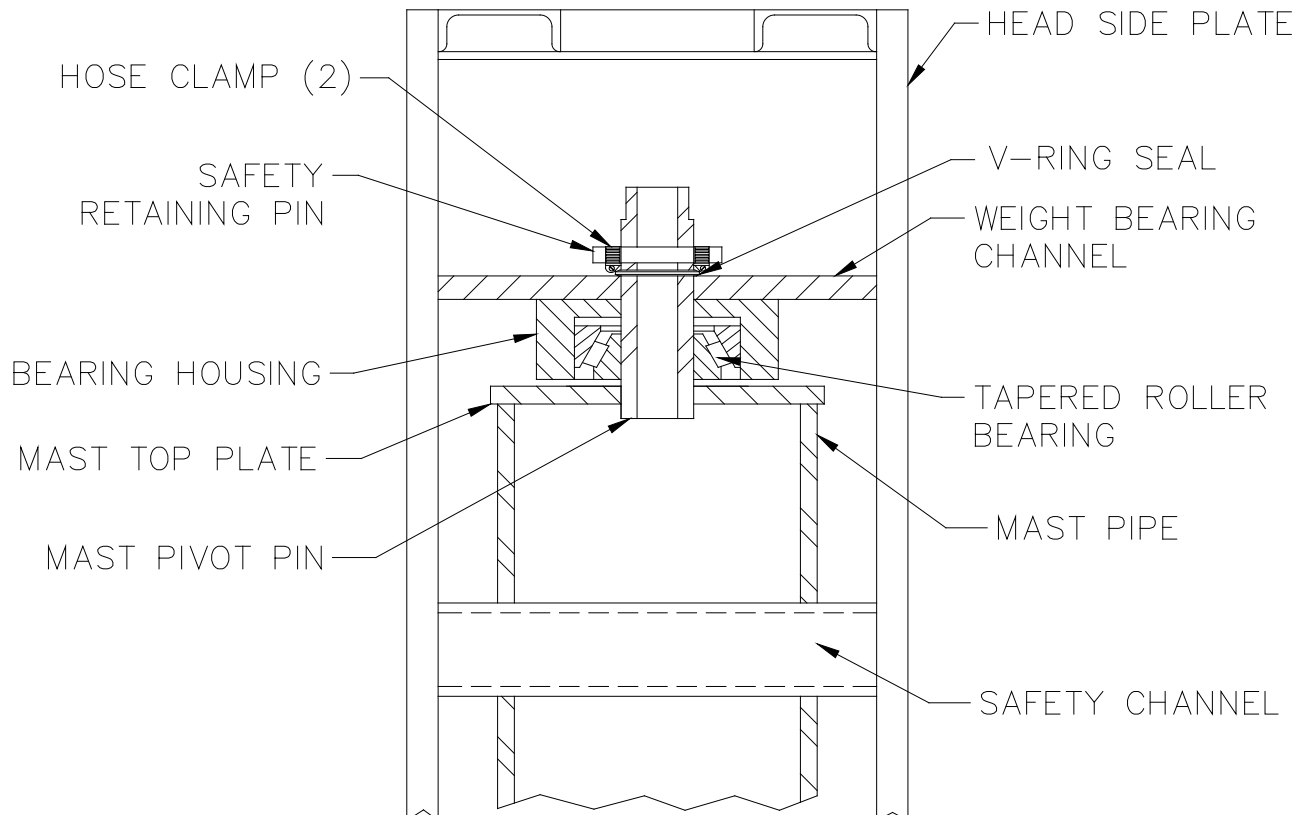

Diagram 4B. Head Assembly Installation.

STEP 5 - BOOM INSTALLATION

➡ **TIP:** If you have a bottom entry collector, install it prior to Step 5. See page 14.

5.1 Set the boom on the head and attach to the head using the hardware provided. Two (2) bolts are required in the front (under boom hardware) and all holes in the back of boom plate require bolts (*diagram 5A*).

5.2 Adjust the boom to a point of $L/300$ (length of span in inches divided by 300) above level at tip of span. Leveling is done by adding shims (by others) under the boom at the front of the head (when the pipe diameter (E) is 8", 12", 14", 16", 18" or 20") (*diagram 5B*), or by evenly adjusting the hexnuts on the threaded rod on the trunnion roller assembly (when the pipe diameter (E) is 24" or 30") (*diagram 5C*).

5.3 Torque the back of boom mounting hardware and the under boom hardware per *chart 1A*, page 2.

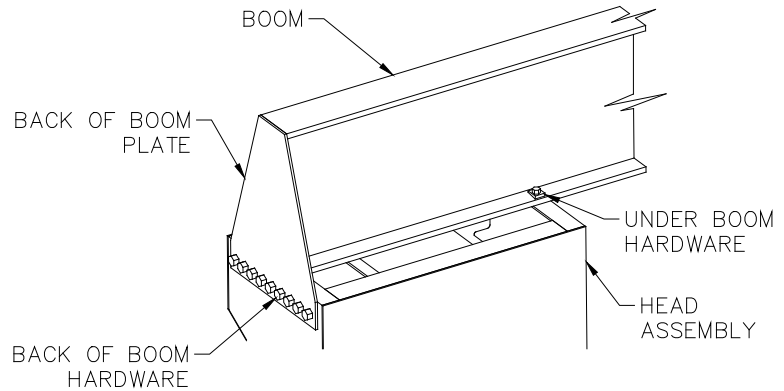

Diagram 5A. Boom Installation.

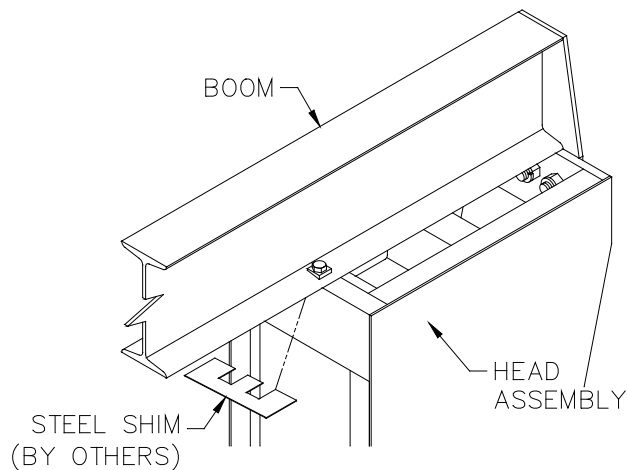

Diagram 5B. Shimming boom.

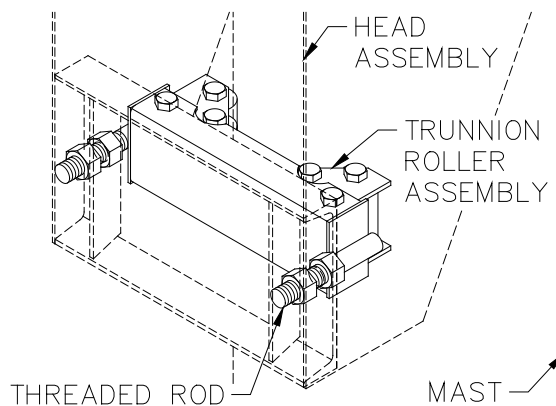

Diagram 5C. Adjusting trunnion roller assembly.

STEP 6 - ENDSTOP/TAGLINE INSTALLATION

TIP: If you have tagline go to Step 6.2, otherwise go to Step 6.1.

6.1 Endstop Installation (*diagram 6A*)

- A) Bolt endstops to end of boom closest to the mast. Torque nuts (refer to **chart 1A**, page 2, for proper torque rating).
- B) Roll hoist/hoist trolley (by others) into place.
- C) Immediately bolt remaining endstops into place at the front of boom. Torque nuts (refer to **chart 1A**, page 2, for proper torque rating).

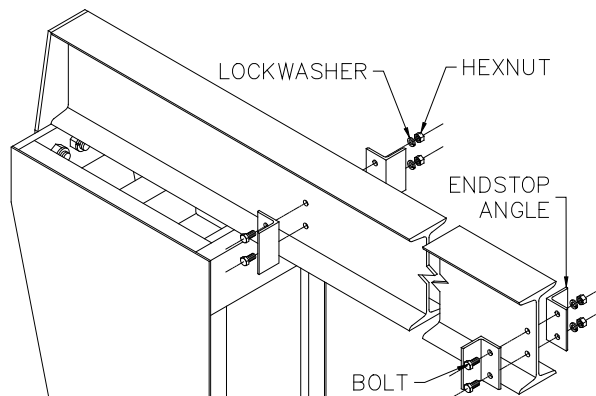

Diagram 6A. Endstop installation.

6.2 Tagline Festoon Installation (*diagram 6B*)

- A) Bolt tagline bracket and an endstop to end of boom closest to the mast. Torque nuts (refer to **chart 1A**, page 2, for proper torque rating).
- B) Roll hoist/hoist trolley (by others) into place.
- C) Immediately bolt remaining tagline bracket and endstop into place at the front of boom. Torque nuts (refer to **chart 1A**, page 2, for proper torque rating).

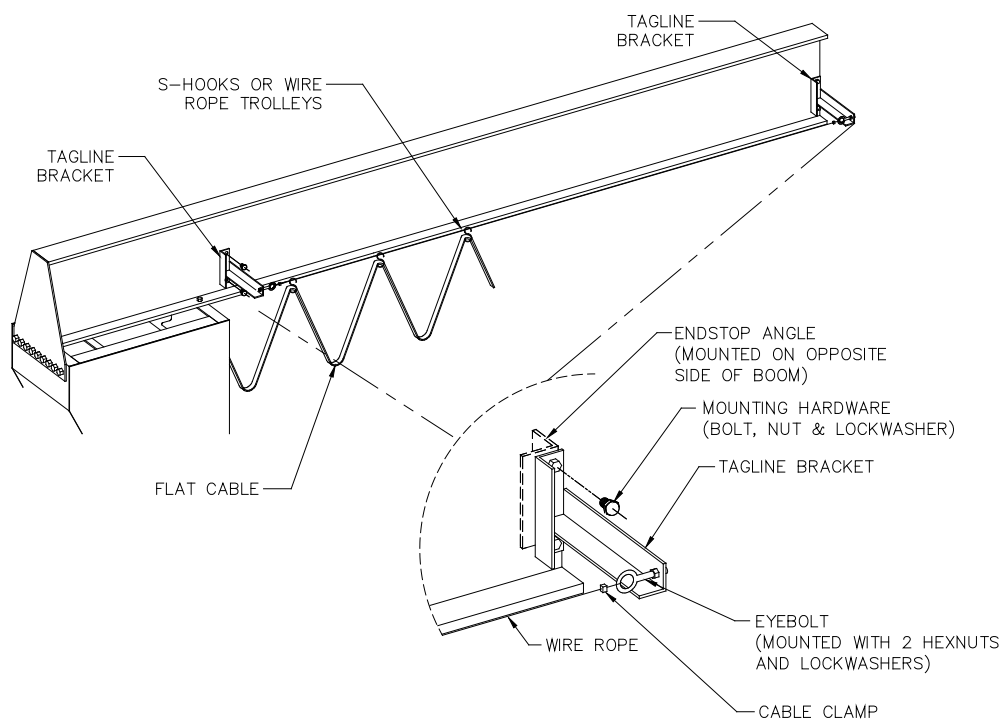

Diagram 6B. Tagline festoon installation.

- D) Bolt eyebolts to tagline brackets using two hexnuts per eyebolt.
- E) Loop the wire rope through one of the eyebolts and clamp the loop using cable clamps. Repeat this step at the other eyebolt while removing any slack from the wire rope.
- F) Adjust the eyebolts to achieve the desired cable tension and lock the eyebolts in place by tightening the hexnuts.
- G) Run the festoon cable through the S-hooks or wire rope trolleys (squeeze bottom of S-hooks to grip cable or hose).
- H) Wire the hoist per manufacturers (SIC) instructions.

STEP 7 - OPTIONAL ACCESSORIES

Electrical Bottom Entry Collector (*diagram 7A*)

- A) Remove the collector cover. Remove hose clamps and safety retaining pin if crane requires an adaptor pin (see packing list).
- B) Install the collector adaptor pin (if applicable) being sure wires from mast come up through the center.
- C) Reinstall the safety retaining pin and hose clamps if previously removed.
- D) Connect wires protruding from mast pin to the inside of the collector.
- E) Place the bottom entry collector on top of pivot pin (or adaptor pin) and secure with the set screws. Make sure wires are pushed down inside mast.
- F) Connect collector to the bolt mounted in the weight bearing channel using connecting link and hardware provided.
- G) Add appropriate size hole in the collector cover or front of weight bearing channel to allow installation of hoist power cable to collector.
- H) Wire from collector to hoist.
- I) Attach collector cover with hardware provided.

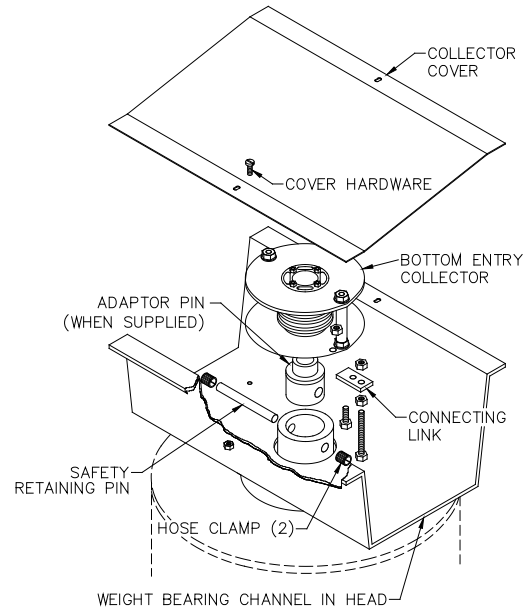

Diagram 7A. *Installing bottom entry collector.*

Electrical Top Entry Collector (*diagram 7B*)

- A) Position the collector over the mounting hole pattern on top of the mounting plate.
- B) Bolt collector assembly to the mounting plate with the hardware provided.
- C) Bring power down from overhead source and wire into pivot arm of the collector assembly with conduit.
- D) Wire from the collector assembly to the hoist.

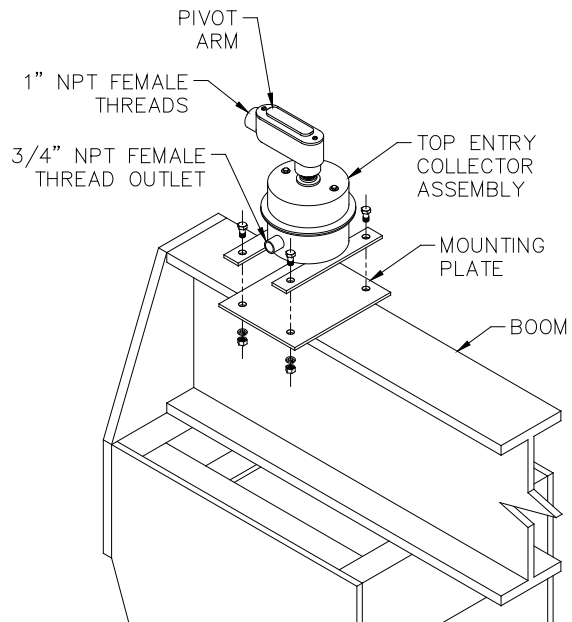

Diagram 7B. *Installing top entry collector.*

STEP 7 - OPTIONAL ACCESSORIES (CONTINUED)

WARNING

Welds must meet American Welding Society (AWS) specification D1.1 using E70xx electrodes.

Mechanical Rotation Stops (diagram 7C)

E	8	12	14	16	18	20	24	30
A	2-1/2"	2-3/4"	16-1/2"	16-1/2"	16-1/2"	16-1/2"	17-1/2"	17-1/2"

- Weld stationary stop blocks to mast.
- Weld rotation stop block to center of safety channel. Leave 1/4" gap between mast and rotation stop block.

Multi-Position or Single Position Locking Device (diagram 7D)

- Bolt mounting channels to head assembly.
- Bolt vertical channel assembly to the mounting channels.
- Move the lock clamp handle until the locking block falls into the slot in the position lock ring.
- Rotate the crane to the desired locking position. Unless otherwise specified, the slots on the lock ring are on 30° offset.

Note: Multi-position or single position locking ring can either be factory mounted or field mounted.

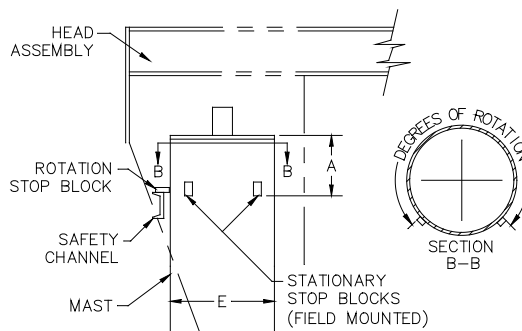

Diagram 7C. Installing rotation stops.

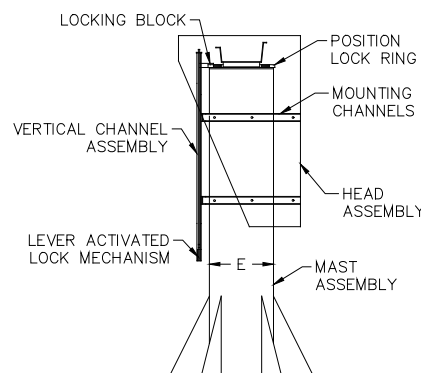

Diagram 7D. Installing locking device.

WARNING

Locking device not to be used for side loading, it is strictly used to prevent rotation of head and boom when lifting and lowering load directly below beam. Not to be used as a wind lock.

Other Options Available from Gorbel (Consult Gorbel® Representative)

- Anchor Bolts
- Bottom Entry Air Swivel
- Powered Rotation
- Base Plate Template
- Top Entry Air Swivel
- Fusible Disconnect Switch
- Flat or Round Conductor Cable
- Wire Rope Trolleys for Flat or Round Cable

STEP 8 - FINAL STEPS

TIP: Do not throw away this manual: maintenance schedule is on back cover.

- Check to make sure all bolts are tight and lockwashers are compressed.
- If necessary, touch up with paint provided.
- Keep Packing List, Installation Manual, General Arrangement Drawing and any other inserts together in a safe place.

CRANE OPERATOR INSTRUCTIONS

Overhead cranes and jib cranes generally handle materials over working areas where there are personnel. Therefore, it is important for the Crane Operator to be instructed in the use of the crane and to understand the severe consequences of careless operation.

It is not intended that these suggestions take precedence over existing plant safety rules and regulations or OSHA regulations. However, a thorough study of the following information should provide a better understanding of safe operation and afford a greater margin of safety for people and machinery on the plant floor.

It must be recognized that these are suggestions for the Crane Operator's use. It is the responsibility of the owner to make personnel aware of all federal, state and local rules and codes, and to make certain operators are properly trained.

Qualifications

Crane operation, to be safe and efficient, requires skill: the exercise of extreme care and good judgment, alertness and concentration, and rigid adherence to proven safety rules and practices as outlined in applicable and current ANSI and OSHA safety standards. In general practice, no person should be permitted to operate a crane:

- Who cannot speak the appropriate language or read and understand the printed instructions.
- Who is not of legal age to operate this type of equipment.
- Whose hearing or eyesight is impaired (unless suitably corrected with good depth perception).
- Who may be suffering from heart or other ailments which might interfere with the operator's safe performance.
- Unless the operator has carefully read and studied this operation manual.
- Unless the operator has been properly instructed.
- Unless the operator has demonstrated his instructions through practical operation.
- Unless the operator is familiar with hitching equipment and safe hitching equipment practices.

Handling the Jib Boom Motion

Before using the boom of the jib crane, the operator should be sure the hook is high enough to clear any obstruction. Before a load is handled by the crane, the jib boom should be brought into position so that it is directly over the load. Start the jib boom slowly and bring it up to speed gradually. Approaching the place where it is desired to stop the jib, reduce the boom speed.

Handling the Trolley Motion

Before a load is handled, the hoist should be positioned directly over the load that is to be handled. When the slack is taken out of the slings, if the hoist is not directly over the load, bring it directly over the load before hoisting is continued. Failure to center the hoist over the load may cause the load to swing upon lifting. Always start the trolley motion slowly and reduce the trolley speed gradually.

Handling the Hoist Motion

Refer to the lifting (hoist) equipment's operating instructions.

GENERAL SUGGESTIONS

Know Your Crane

Crane operators should be familiar with the principal parts of a crane and have a thorough knowledge of crane control functions and movements. The crane operator should be required to know the location and proper operation of the main conductor disconnecting means for all power to the attachments on the crane.

Responsibility

Each crane operator should be held directly responsible for the safe operation of the crane. Whenever there is any doubt as to SAFETY, the crane operator should stop the crane and refuse to handle loads until: (1) safety has been assured or (2) the operator has been ordered to proceed by the supervisor, who then assumes all responsibility for the SAFETY of the lift.

Do not permit **ANYONE** to ride on the hook or a load.

Inspection

Test the crane movement and any attachments on the crane at the beginning of each shift. Whenever the operator finds anything wrong or apparently wrong, the problem should be reported immediately to the proper supervisor and appropriate corrective action taken.

Operating Suggestions

One measure of a good crane operator is the smoothness of the crane operation. The good crane operator should know and follow these proven suggestions for safe, efficient crane handling.

1. The crane should be moved smoothly and gradually to avoid abrupt, jerky movements of the load. Slack must be removed from the sling and hoisting ropes before the load is lifted.
2. Center the crane over the load before starting the hoist to avoid swinging the load as the lift is started. Loads should not be swung by the crane to reach areas not under the crane.
3. Crane-hoisting ropes should be kept vertical. Cranes shall not be used for side pulls.
4. Be sure everyone in the immediate area is clear of the load and aware that a load is being moved.
5. Do not make lifts beyond the rated load capacity of the crane, sling chains, rope slings, etc.
6. Make certain that before moving the load, load slings, load chains, or other lifting devices are fully seated in the saddle of the hook with hook latch closed (if equipped with hook latch).
7. Check to be sure that the load and/or bottom block is lifted high enough to clear all obstructions when moving boom or trolley.
8. At no time should a load be left suspended from the crane unless the operator has the push button with the power on, and under this condition keep the load as close as possible to the floor to minimize the possibility of an injury if the load should drop. When the crane is holding a load, the crane operator should remain at the push button.
9. Do not lift loads with sling hooks hanging loose. If all sling hooks are not needed, they should be properly stored, or use a different sling.
10. All slings or cables should be removed from the crane hooks when not in use (dangling cables or hooks hung in sling rings can inadvertently snag other objects when the crane is moving).
11. Operators shall not carry loads and/or empty bottom blocks over personnel. Particular additional caution should be practiced when using magnet or vacuum devices. Loads, or parts of loads, held magnetically could drop. Failure to power magnets or vacuum devices can result in dropping the load. Extra precaution should be exercised when handling molten metal in the proximity of personnel.
12. Whenever the operator leaves the crane the following procedure should be followed:
 - Raise all hooks to an intermediate position.
 - Spot the crane at an approved designated location.
 - Place all controls in the "off" position.
 - Open the main switch to the "off" position.
 - Make visual check before leaving the crane.
13. In case of emergency or during inspection, repairing, cleaning or lubrication, a warning sign or signal should be displayed and the main switch should be locked in the "off" position. This should be done whether the work is being done by the crane operator or by others.
14. Contact with rotation stops or trolley end stops shall be made with extreme caution. The operator should do so with particular care for the safety of persons below the crane, and only after making certain that any persons on the other cranes are aware of what is being done.
15. ANY SAFETY FEATURES AND MECHANISMS BUILT-IN OR OTHERWISE PROVIDED WITH THE CRANE BY GORBEL ARE REQUIRED FOR THE SAFE OPERATION OF THE CRANE. DO NOT, UNDER ANY CIRCUMSTANCES, REMOVE OR OTHERWISE IMPAIR OR DISABLE THE PROPER FUNCTIONING OF ANY CRANE SAFETY MECHANISMS OR FEATURES BUILT-IN OR OTHERWISE PROVIDED BY GORBEL FOR SAFE OPERATION OF THE CRANE. ANY REMOVAL, IMPAIRMENT OR DISABLING OF ANY SUCH SAFETY MECHANISMS OR FEATURES OR OTHER USE OR OPERATION OF THE CRANE WITHOUT THE COMPLETE AND PROPER FUNCTIONING OF ANY SUCH SAFETY MECHANISMS OR FEATURES AUTOMATICALLY AND IMMEDIATELY VOIDS ANY AND ALL EXPRESS AND IMPLIED WARRANTIES OF ANY KIND OR NATURE.

LIMITED WARRANTY

It is agreed that the equipment purchased hereunder is subject to the following LIMITED warranty and no other. Gorbel Incorporated ("Gorbel") warrants the manual push-pull Work Station Cranes, Jib Crane, and Gantry Crane products to be free from defects in material or workmanship for a period of ten years or 20,000 hours use from date of shipment. Gorbel warrants the Motorized Work Station Cranes and Jib Crane products to be free from defects in material or workmanship for a period of two years or 4,000 hours use from the date of shipment. Gorbel warrants the G-Force® and Easy Arm™ products to be free from defects in material or workmanship for a period of one year or 2,000 hours use from the date of shipment. This warranty does not cover Gantry Crane wheels. This warranty shall not cover failure or defective operation caused by operation in excess of recommended capacities, misuses, negligence or accident, and alteration or repair not authorized by Gorbel. No system shall be field modified after manufacture without the written authorization of Gorbel, Inc. Any field modification made to the system without the written authorization of Gorbel, Inc. shall void Gorbel's warranty obligation. OTHER THAN AS SET FORTH HEREIN, NO OTHER EXPRESS WARRANTIES, AND NO IMPLIED WARRANTIES, ORAL OR WRITTEN, INCLUDING BUT NOT LIMITED TO THE WARRANTIES OF MERCHANTABILITY OR FITNESS FOR PARTICULAR PURPOSE, ARE MADE BY GORBEL WITH RESPECT TO ITS PRODUCTS AND ALL SUCH WARRANTIES ARE HEREBY SPECIFICALLY DISCLAIMED. GORBEL SHALL NOT BE LIABLE UNDER ANY CIRCUMSTANCES FOR ANY INCIDENTAL, SPECIAL AND/OR CONSEQUENTIAL DAMAGES WHATSOEVER, WHETHER OR NOT FORESEEABLE, INCLUDING BUT NOT LIMITED TO DAMAGES FOR LOST PROFITS AND ALL SUCH INCIDENTAL, SPECIAL AND/OR CONSEQUENTIAL DAMAGES ARE HEREBY ALSO SPECIFICALLY DISCLAIMED. Gorbel's obligation and Purchaser's or end user's sole remedy under this warranty is limited to the replacement or repair of Gorbel's products at the factory, or at the discretion of Gorbel, at a location designated by Gorbel. Purchaser or end user shall be solely responsible for all freight and transportation costs incurred in connection with any warranty work provided by Gorbel hereunder. Gorbel will not be liable for any loss, injury or damage to persons or property, nor for damages of any kind resulting from failure or defective operation of any materials or equipment furnished hereunder. Components and accessories not manufactured by Gorbel are not included in this warranty. Purchaser's or end user's remedy for components and accessories not manufactured by Gorbel is limited to and determined by the terms and conditions of the warranty provided by the respective manufacturers of such components and accessories.

A) DISCLAIMER OF IMPLIED WARRANTY OF MERCHANTABILITY

Gorbel and Purchaser agree that any claim made by Purchaser which is inconsistent with Gorbel's obligations and the warranty remedies provided with Gorbel's products, and in particular, special, incidental and consequential damages, are expressly excluded.

B) DISCLAIMER OF IMPLIED WARRANTY OF FITNESS FOR PARTICULAR PURPOSE

Gorbel and Purchaser agree that the implied warranty of fitness for particular purpose is excluded from this transaction and shall not apply to the goods involved in this transaction.

C) DISCLAIMER OF EXPRESS WARRANTY

Gorbel's agents, or dealer's agents, or distributor's agents may have made oral statements about the machinery and equipment described in this transaction. Such statements do not constitute warranties, and Purchaser agrees not to rely on such statements. Purchaser also agrees that such statements are not part of this transaction.

D) DISCLAIMER OF SPECIAL, INCIDENTAL AND CONSEQUENTIAL DAMAGES

Gorbel and Purchaser agree that any claim made by Purchaser which is inconsistent with Gorbel's obligations and the warranty remedies provided with Gorbel's products, and in particular, special, incidental and consequential damages, are expressly excluded.

E) DEALER OR DISTRIBUTOR NOT AN AGENT

Gorbel and Purchaser agree that Purchaser has been put on notice that dealer or distributor is not Gorbel's agent in any respect for any reason. Gorbel and Purchaser also agree that Purchaser has been put on notice that dealer or distributor is not authorized to incur any obligations or to make any representations or warranties on Gorbel's behalf other than those specifically set forth in Gorbel's warranty provided in connection with its product.

F) MERGER

This warranty agreement constitutes a final and complete written expression of all the terms and conditions of this warranty and is a complete and exclusive statement of those terms.

G) PAINTING

Every crane (excluding components) receives a quality paint job before leaving the factory. Unfortunately, no paint will protect against the abuses received during the transportation process via common carrier. We have included at least one (1) twelve ounce spray can for touchup with each crane ordered (unless special paint was specified). If additional paint is required, contact a Gorbel® Customer Service Representative at 1-800-821-0086 or 1-585-924-6262.

Title and Ownership:

Title to the machinery and equipment described in the foregoing proposal shall remain with Gorbel and shall not pass to the Purchaser until the full amount herein agreed to be paid has been fully paid in cash.

Claims and Damages:

Unless expressly stated in writing, goods and equipment shall be at Purchaser's risk on and after Seller's delivery in good shipping order to the Carrier. Gorbel shall in no event be held responsible for materials furnished or work performed by any person other than it or its authorized representative or agent.

Cancellations:

If it becomes necessary for the purchaser to cancel this order wholly or in part, he shall at once so advise Gorbel in writing. Upon receipt of such written notice all work will stop immediately. If the order entails only stock items, a flat restocking charge of 15% of the purchase price will become due and payable by Purchaser to Gorbel. Items purchased specifically for the canceled order shall be charged for in accordance with the cancellation charges of our supplier plus 15% for handling in our factory. The cost of material and/or labor expended in general fabrication for the order shall be charged for on the basis of total costs to Gorbel up to the time of cancellation plus 15%.

Returns:

No equipment, materials or parts may be returned to Gorbel without express permission in writing to do so.

Extra Charge Delay: If Purchaser delays or interrupts progress of Seller's performance, or causes changes to be made, Purchaser agrees to reimburse Gorbel for expense, if any, incident to such delay.

Changes and Alterations:

Gorbel reserves the right to make changes in the details of construction of the equipment, as in its judgment, will be in the interest of the Purchaser; will make any changes in or additions to the equipment which may be agreed upon in writing by the Purchaser; and Gorbel is not obligated to make such changes in products previously sold any customer.

Third Party Action:

Should Gorbel have to resort to third party action to collect any amount due after thirty (30) days from date of invoice, the Purchaser agrees to pay collection costs, reasonable attorney's fees, court costs and legal interest.

OSHA Responsibilities:

Gorbel agrees to fully cooperate with Purchaser in the design, manufacture or procurement of safety features or devices that comply with OSHA regulations. In the event additional equipment or labor shall be furnished by Gorbel, it will be at prices and standard rates then in effect, or as may be mutually agreed upon at the time of the additional installation.

Equal Employment Opportunity:

Gorbel agrees to take affirmative action to ensure equal employment opportunity for all job applicants and employees without regard to race, color, age, religion, sex, national origin, handicap, veteran, or marital status. Gorbel agrees to maintain non-segregated work facilities and comply with rules and regulations of the Secretary of Labor or as otherwise provided by law or Executive Order.

INSPECTION AND MAINTENANCE SCHEDULE

GORBEL® FREE STANDING JIB CRANE INSPECTION AND MAINTENANCE SCHEDULE			
ITEM	COMPONENT	MAINTENANCE	FREQUENCY*
1	Anchor Bolts	Check that lockwashers are compressed and nuts tightened to manufacturer's specifications.	Every 500 hours or 3 months
2	Boom Attachment Hardware	Check that lockwashers are compressed and bolts are tightened to torque specifications (chart 1A, page 2).	Every 500 hours or 3 months
3	Trunnion Rollers	Check to make sure both rollers have full face contact with mast pipe and that lockwashers are compressed.	Every 1000 hours or 6 months
4	Endstop/Tagline Assemblies	Check that lockwashers are compressed and bolts are tightened to torque specifications (chart 1A, page 2).	Every 500 hours or 3 months
5	Level of Boom	Verify end of boom is at a point of L/300 above level. Reference page 11, Boom Installation.	Every 1000 hours or 6 months
6	Accessory Items	Conduct a general inspection of all accessory items.	Every 1000 hours or 6 months
7	Gorbel® Crane	Conduct a visual inspection of crane overall.	Every 1000 hours or 6 months

* Federal, state and local codes may require inspection and maintenance checks more often. Please check the federal, state and local code manuals in your area.

WARNING

Any changes in rolling effort, rotation effort or unusual noises must be immediately identified and corrected.

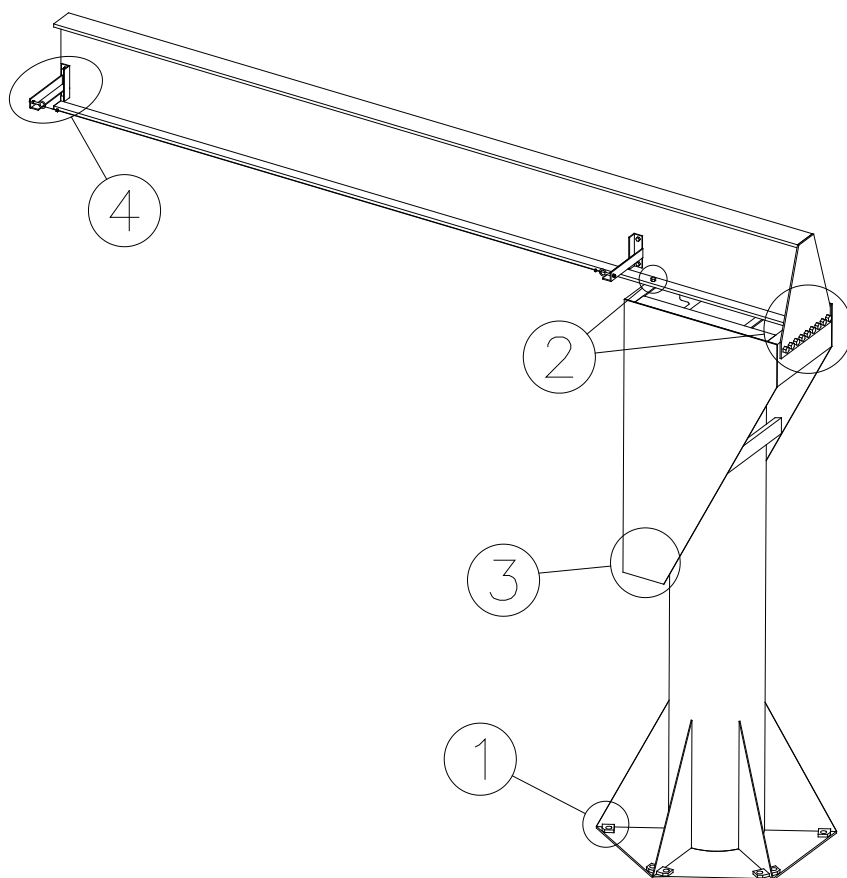

GORBEL®

600 Fishers Run, P.O. Box 593
Fishers, NY 14453-0593

Distributed by Ergonomic Partners
Sales@ErgonomicPartners.com
www.ErgonomicPartners.com
Tel: (314) 884-8884

© 2011 Gorbel Inc.
All Rights Reserved