

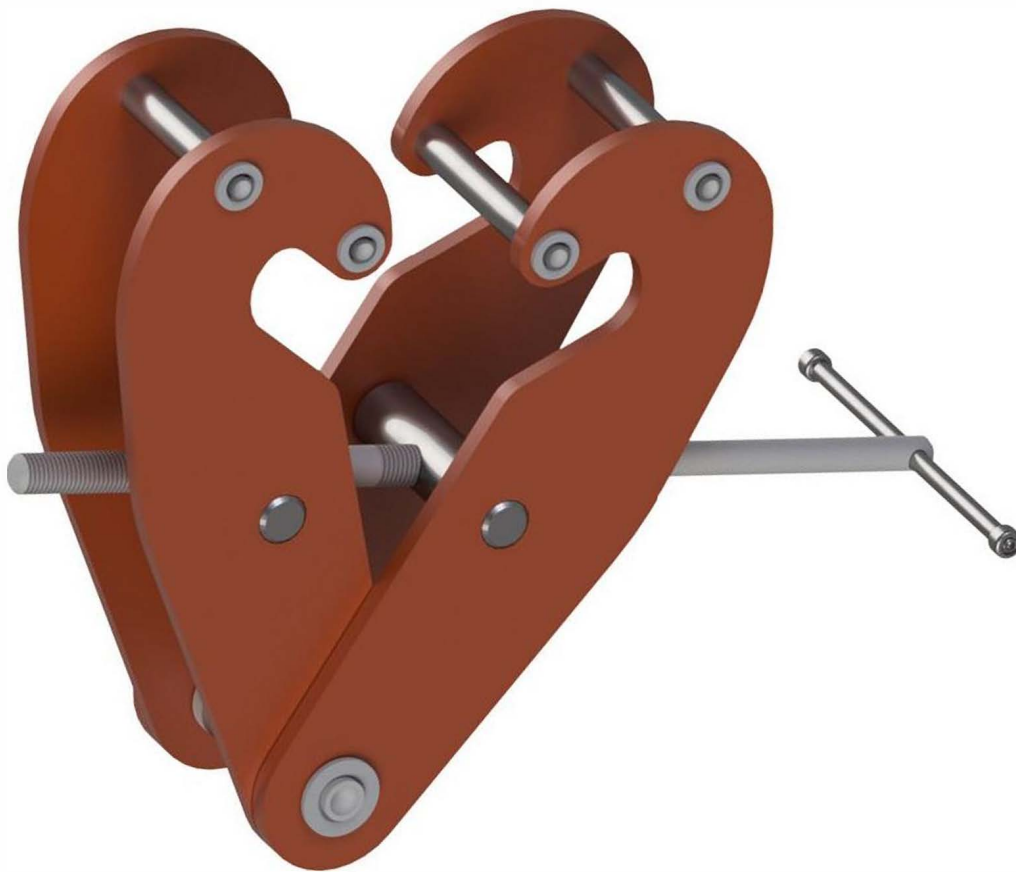

## GS GIRDER CLAMP USER MANUAL



**ELEPHANT**  
**LIFTING PRODUCTS™**

Distributed by Ergonomic Partners

[Sales@ErgonomicPartners.com](mailto:Sales@ErgonomicPartners.com)

[www.ErgonomicPartners.com](http://www.ErgonomicPartners.com)

Tel: 314-884-8884



## **Contents**

Preface .....	2
Safety Information .....	3
1 Identification .....	5
2 Product Description .....	5
2.1 Main Components .....	5
3 Intended Use .....	5
4 Operating Conditions .....	5
5 Transport and Storage .....	6
5.1 Safe Transportation .....	6
5.2 Breaks in Operation .....	6
5.3 Storage.....	6
6 Initial Operation .....	6
6.1 Installation of the Girder Clamp .....	6
6.2 Lubrication .....	7
7 Inspection .....	7
7.1 Initial Inspection .....	7
7.2 Every Lift Inspection .....	7
7.3 Frequent Inspection.....	7
7.4 Periodic Inspection .....	7
7.5 Daily Inspection for Machines Operated in Corrosive Environments.....	8
7.6 Girder Clamp Not in Regular Use.....	8
8 Operation .....	8
8.1 Rules for the Safe Operation of Girder Clamps .....	8
8.2 Operating Limits of the Girder Clamp.....	8
9 Maintenance .....	9
9.1 Maintenance and Inspection Intervals .....	9
9.2 Cleaning and Care .....	9
9.3 Spare Parts.....	9
10 Technical Data.....	10

This operation manual edition 06/2017 covers Elephant Lifting Products Girder Clamps:

It must be read carefully and in its entirety before operating any girder clamp.

Serial No.

Please enter the Serial No. of your Elephant Lifting Products girder clamp here.

**THIS MANUAL MUST BE READ BEFORE USING THESE PRODUCTS.**

This manual contains important safety, installation, operation, and maintenance and repair information. Make this manual available to all persons responsible for the operation, installation, maintenance and repair of these products.

**Do not use this clamp for lifting, supporting, or transporting people or lifting or supporting loads over people.**

**For Clamps used outside of South Africa:**

It is the responsibility of the owner/user to install, inspect, test, maintain, and operate a clamp in accordance with ANSI/ASME B30.20, "Safety Standard for Below-the-Hook-Lifting-Devices", OSHA regulations. If the girder clamp is installed as part of a total lifting system, such as an overhead crane or monorail, it is also the responsibility of the owner/user to comply with the applicable ANSI/ASME B30 volume that addresses that type of equipment must also be read by all personnel.

If the girder clamp owner/user requires additional information, or if any information in the manual is not clear, contact Elephant Lifting Products or the distributor of the girder clamp. Do not install, inspect, test, maintain, or operate this girder clamp unless this information is fully understood.

A regular schedule of inspection of the girder clamp in accordance with the requirements of ANSI/ASME B30.20 should be established and records maintained.

## **Preface**

Elephant Lifting Products warrants to the user its girder clamps, and other products to be free from defects in material and workmanship for a period of one year from the date of purchase.

Elephant Lifting Products will repair, without cost to the user, any product found to be defective, including parts and labour charges, or at Elephant Lifting Products 's option, will replace such products or refund the purchase price less a reasonable allowance for handling in exchange for the product. Repair and replacements are warranted for the remainder of the original warranty period.

If any product proves defective within its original one year warranty period, it shall be returned to Elephant Lifting Products with proof of purchase and the original test certificate.

This warranty does not apply to products which Elephant Lifting Products has determined to have been misused or abused, improperly maintained by the user, or where the malfunction or defect can be attributed to the use of non-genuine Elephant Lifting Products parts.

Elephant Lifting Products makes no other warranty and its maximum liability is limited to the purchase price of the product and in no event will Elephant Lifting Products not be liable for any consequential, indirect, incidental or special damages of any nature arising from the sale or use of the product whether based on contract or otherwise.

It is Elephant Lifting Products policy to promote safety of all persons and equipment in the workplace. All equipment manufactured is thoroughly checked, packed and inspected before dispatch. Any loss or damage which occurs during shipment while en-route must be reported to Elephant Lifting Products immediately. Should any item be delivered to you in apparent good condition, but upon opening the container, loss or damage has taken place while in transit; notify Elephant Lifting Products immediately. Should any items be delivered back to Elephant Lifting Products all transport costs will be for the account of the user.

These instructions are prepared by Elephant Lifting Products for the purpose of maintenance.

No responsibility for failure of equipment due to manufacturing procedure will be assumed if these instructions are not carried out.

## Safety Information

This manual will refer to existing legal requirements and engineering practices as known when this document was written. Should any such legislation or practices change or be “enlarged” upon then due consideration must be taken. Various standards have been used to assist in compiling this document and will be listed where applicable.

The use of powerful lifting equipment is subject to certain hazards that cannot be overcome by mechanical means but only by the exercise of intelligence, care and common sense. It is therefore essential that personnel involved in the use and operation of equipment must be competent, careful, physically and mentally qualified, and trained in the safe operation of equipment and the handling of the loads. Serious hazards include but are not limited to are overloading, dropping or slipping of the load caused by improper hitching or slinging, obstructing the free passage of the load and using equipment for a purpose for which it was not intended or designed. The above can lead to fatal consequences.

Operators of Elephant Lifting Products Girder Clamps are also under obligation to ensure safe and hazard-free operation. This can be achieved through the following measures:

- Keep the operation manuals available at the girder clamp operating site,
- Performing regular training,
- Performing regular inspections (at least once annually),
- Implement an inspection log and make regular entries,
- And regularly check personnel for safety and hazard awareness during work.

Elephant Lifting Products (PTY) LTD fully realizes the importance of proper design factors, minimum and maximum sizes and other limiting dimensions of the structural components of the clamp, all of which are designed with safety in mind.

The various conditions of the equipment or material can vary depending on the environment they are used in which may cause corrosion or wear and any other variables that may arise in each individual application. It is in the light of this that the girder clamp be maintained and repaired under the supervision of a competent person:

- 1) Who is qualified by virtue of his knowledge, training, skills and experience to organize the work and its performance;
- 2) Who is familiar with the legal requirements which apply to the work to be performed;
- 3) Who has been trained to recognize any potential or actual danger to health and safety in the performance of the work.

The instructions given in this manual must be interpreted accordingly and sound judgment used in determining their application.

This operation manual is intended to help the operator to become familiar with Elephant Lifting Products girder clamps and how to use them properly.

This operation manual contains important information for the safe, proper and efficient operation of Elephant Lifting Products girder clamps. Observance of the manual helps to avoid hazardous situations, to reduce repair costs and downtimes and to ensure the specified service life of the Elephant Lifting Products Girder Clamps.

**Always keep the manual readily available at the location where the Elephant Lifting Products girder clamp is being used.**

**All persons charged with operating, maintaining or repairing Elephant Lifting Products girder clamp must read and follow the instructions in this manual.**

### **Danger, Warning, Caution and Notice**

Throughout this manual there are steps and procedures which, if not followed, may result in an injury. The following signal words are used to identify the level of potential hazard.

**DANGER**

Danger is used to indicate the presence of hazard which will cause **severe** injury, death or substantial property damage if the warning is ignored.

**WARNING**

Warning is used to indicate the presence of a hazard which **can** cause **severe** injury, death, or substantial property damage if the warning is ignored.

**CAUTION**

Caution is used to indicate the presence of a hazard which **will** or **can** cause minor injury or property damage if the warning is ignored.

**NOTICE**

Notice is used to notify people of installation, operation, or maintenance information which are important but not hazard-related.

## Safety Summary

### WARNING

- Do not use this girder clamp or any equipment attached to it for lifting, supporting, or transporting people or lifting or supporting loads over people.
- Elephant Lifting Products GS series of girder clamps are designed to provide a MINIMUM of 5 to 1 safety factor. It is the responsibility of the customer to ensure that the structure to which the girder clamp is attached and any load attaching devices are capable of handling the static and dynamic loads imposed on the structure by the girder clamp and its attachments when lifting the rated load. If in doubt, consult a registered professional structural engineer.

### NOTICE

- Lifting equipment is subject to different regulations in each country. These regulations may not be specified in this manual.
- Whenever a conflict arises between the contents of this manual and any other applicable legislation, standard or procedure, the more stringent of the two must be applied.

The Occupational Health and Safety Act and Mine Health and Safety Act and other recognized safety sources make a common point: Employees who work near cranes or assist in hooking on or arranging a load should be instructed to keep out from under the load.

From a safety standpoint, one factor is paramount: conduct all lifting operations in such a manner that if there were an equipment failure, no personnel would be injured. This means keep out from under a raised load and keep out of the intended path of any load.

**Elephant Lifting Products** girder clamps are manufactured in accordance with the latest ISO9001 standards.

The Occupational Safety and Health Act of 1993, section 10 states:

- 1) Any person who designs, manufactures, imports, sells or supplies any article for use at work shall ensure, as far as is reasonably practicable, that the article is safe and without risks to health when properly used and that it complies with all prescribed requirements.
- 2) Any person who erects or installs any article for use at work on or in any premises shall ensure, as far as is reasonably practicable, that nothing about the

manner in which it is erected or installed makes it unsafe or creates a risk to health when properly used.

- 3) Any person who manufactures, imports, sells or supplies any substance for use at work shall –
  - (a) ensure, as far as is reasonably practicable, that the substance is safe and without risks to health when properly used; and
  - (b) take such steps as may be necessary to ensure that information is available with regard to the use of the substance at work, the risks to health and safety associated with such substance, the conditions necessary to ensure that the substance will be safe and without risks to health when properly used and the procedures to be followed in the case of an accident involving such substance.
- 4) Where a person designs, manufactures, imports, sells, or supplies an article or substance for or to another person, and that other person, and that other person undertakes in writing to take specified steps sufficient to ensure, as far as is reasonable practicable, that the article or substance will comply with all prescribed requirements and will be safe and without risks to health when properly used, the undertaking shall have the effect of relieving the first mentioned person from the duty imposed upon him by this section to such an extent as may be reasonable having regard to the terms of the undertaking.

It is the owner's and user's responsibility to determine the suitability of a product for any particular use. It is recommended that all applicable industry, trade association and legislation be checked. Read all operation instructions and warnings before operation. This manual has been produced by **Elephant Lifting Products** to provide agents, fitters, and company personnel with the information required to install, operate, maintain and repair the products described herein.

It is extremely important that fitters and operators be familiar with the servicing procedures of these products, or similar products, and is physically capable of conducting the procedures. These personnel shall have a general working knowledge that includes:

- 1) Proper and safe use and application of fitter's common hand tools as well as special or recommended tools.
- 2) Safety procedures, precautions and work habits established by accepted industry standards.

Elephant Lifting Products cannot nor provide all the procedures by which product operations or repairs may be conducted and the hazards and or results of each method. If operation or maintenance procedures not specifically recommended by the manufacturer are conducted, it must be ensured that product safety is not endangered by the actions taken. If unsure of an operation or maintenance procedure or step, personnel should place the product in a safe condition and contact supervisors and/or the factory for technical assistance.

## 1 Identification

The nameplate mounted on the side plate identifies the type of Elephant Lifting Products girder clamp and contains important rating data.

If you have any questions concerning the operation of Elephant Lifting Products girder clamps which are not addressed in this operation manual, please contact us at the following address:

Elephant Lifting Products  
2718 S Ruby Ave  
Gonzales, Louisiana, 70737  
Phone: (888) 844-6113  
Fax: (225) 644-6695  
e-mail: [sales@elephantlifting.com](mailto:sales@elephantlifting.com)

## 2 Product Description

The Elephant Lifting Products girder clamp is used for applications where a lifting point is required. The clamp is attached directly to the flange of a structural beam for lifting purposes.

The girder clamp is attached with its plates clamped directly onto a beam. The girder clamp can also be suspended with a hook over its hang bar.

Elephant Lifting Products girder clamps are designed in accordance with ASME BTH-1-2011 and correspond to the design category B. They are suitable for girders according to DIN 1025 or similar types of girder.

The girder clamp width is adjusted to fit a girder profile within the range given to you in Section 10.

Fully stainless steel Elephant Lifting Products girder clamp models are available. Sizes might differ from the regular girder clamps.

### 2.1 Main Components

Elephant Lifting Products girder clamps consist of the following main components:

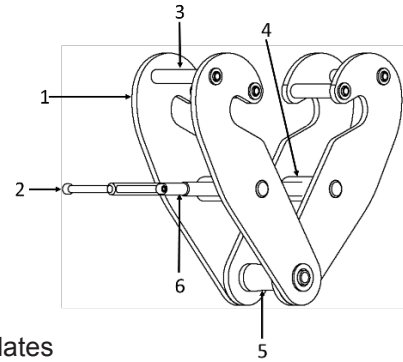

1. Side plates
2. Clamp Handle
3. Support pins
4. Threaded trunnions
5. Hang Bar
6. Jacking threaded rod

## 3 Intended Use

The Elephant Lifting Products girder clamp was designed for quick and easy installation and to enable loads of up to the capacity specified, to be clamped safely. The rated load specified on the component is the maximum load that must not be exceeded.

Elephant Lifting Products girder clamps in combination with Elephant Lifting Products air hoists are intended to be used exclusively for lifting and lowering loads.

Any other use or use outside these stipulations is deemed to be impermissible. For applications requiring this type of use please consider the Elephant Lifting Products range of winches and the Elephant Lifting Products range of hoists. Elephant Lifting Products cannot be held liable for any damage resulting from incorrect usage. The entire risk is borne by the operator.

The following situations, among others, are regarded as improper use:

- Exceeding the permitted load-carrying capacity
- Oblique pulling of loads (Refer to Section 8.2)
- Sliding loads
- Detaching, dragging or pulling of loads
- Catching of falling loads
- Carrying people

See also Rules for the safe operation of girder clamps, Section 8.1.

Intended use also includes observance of the operation manual and compliance with the inspection and maintenance conditions.

## 4 Operating Conditions

Elephant Lifting Products Girder Clamps are extremely robust and require little maintenance. They are suitable for use in areas with



high humidity and ambient temperatures of – 4° C up to approx. 66° C if they are not heated above this level due to external influences.

## CAUTION

When touching metallic parts of the girder clamp, which are colder than 0° C, skin could freeze within a few seconds, and at temperatures above 43° C, burns may occur. As a protective measure, please wear suitable gloves.

For stationary outdoor operation, girder clamps must be protected against weathering and the maintenance intervals must be shortened.

## 5 Transport and Storage

### 5.1 Safe Transportation

If you wish to transport your Elephant Lifting Products Girder Clamps to another site, please observe the following points:

- Carefully dismount girder clamp.
- Set the entire clamp down carefully; do not allow it to drop. For weights see **Technical data**, Section 10.

### 5.2 Breaks in Operation

In the case of longer operational breaks, coat the jacking rod with grease.

### 5.3 Storage

- Always store the clamp in a no load condition.
- Wipe off all dirt and water.
- Grease the jacking rod.
- Store the girder clamp in a clean dry environment.
- Before returning the girder clamp to service, follow instructions for girder clamps not in regular service in Section 7.6.

## 6 Initial Operation

The four most important aspects of girder clamp operation are:

1. Follow all safety instructions when operating the girder clamp.
2. Allow only people trained in safety and operation of this product to work with the clamp.
3. Subject each girder clamp to a regular inspection and maintenance as outlined in this manual under the Section 6 and 9.
4. Be aware of the girder clamps rated load and weight of load at all times.

Operators must be physically competent. Operators must have no health condition which might affect their ability to

act, and they must have good hearing, vision and depth perception. The girder clamp operator must be carefully instructed in his duties and must understand the operation of the hoist, including a study of manufacturer's literature. The operator must thoroughly understand proper methods of hitching loads and should have a good attitude regarding safety. It is the operator's responsibility to refuse to use the clamp under unsafe conditions.

### 6.1 Installation of the Girder Clamp

The girder clamp is to be opened wide enough to fit over the width of the beam. This can be done by rotating the clamp handle in an anti-clockwise direction. Once the clamp fits over the beam rotate the clamp handle clockwise to fasten the clamp onto the beam. The beam clamp must not be put under load during installation. Refer to the figure below for correct and incorrect fastening positions.



Correct:

The arms of the beam clamp are resting on the vertical or horizontal part of the beam flange.



Incorrect:

There is a gap between one or both of the arms of the beam clamp and the beam flange.

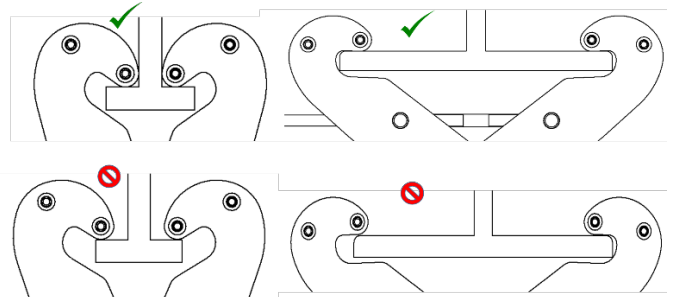

## DANGER

Elephant Lifting Products girder clamps must only be installed by qualified personnel. Faulty installation can lead to serious accidents.

## CAUTION

The girders for the Elephant Lifting Products girder clamps must be able to safely withstand the expected forces.

The calculation of the static load and the selection of the girder profile are the responsibility of the operator. The carrying capacity of the suspended hoist must not be bigger than the capacity of the girder clamp.

Elephant Lifting Products girder clamps are designed for girder profiles or similar profiles.

Please supply adequate working tools.

Please look for a safe place for the mounting personnel.

**DANGER**

Incorrect suspension/loading of the hang bar, i.e. over the flat cross-section, causes danger of fracture and is therefore not permissible.

**DANGER**

Do not drop lifting equipment; equipment should always be placed properly onto the floor.

#### **ATTENTION!**

After mounting please check that the arms of the beam clamp are resting on the vertical or horizontal part of the beam flange.

### **6.2 Lubrication**

To ensure continued satisfactory operation of the girder clamp, all points requiring lubrication must be serviced with the correct lubricant at the proper time interval. Correct lubrication is one of the most important factors in maintaining efficient operation.

The lubrication intervals recommended in this manual are based on intermittent use of the girder clamp eight hours each day, five days per week. If the girder clamp is operated almost continuously or more than the eight hours each day, more frequent lubrication will be required. Lubrication of the jacking threaded rod with standard grease is necessary for standard girder clamps.

**CAUTION**

To prevent thread galling from occurring, grease must be applied more frequently to the stainless steel clamp jacking threaded rod.

## **7 Inspection**

**Elephant Lifting Products** recommends two types of inspection:

1. The frequent inspection performed by the operator as pre-work inspection.
2. The periodic inspections performed by personnel trained in the operation of this girder clamp.

Careful inspection on a regular basis will reveal potentially dangerous conditions while still in the early stages, allowing corrective actions to be taken before the condition becomes dangerous.

Any deficiency revealed through inspection must be reported to an appointed person. A determination must be made as to whether a deficiency constitutes a safety hazard before resuming operation of the clamp.

The results of the inspection must be recorded in an inspection log.

### **7.1 Initial Inspection**

Girder clamps have to comply with the regulations for the prevention of accidents valid for girder clamps. Before beginning to use the girder clamp for the first time it has to be inspected by a designated person. The inspection procedure is that mentioned in Section 7.4. If any deficiencies are identified, the clamp shall be examined by a qualified person.

### **7.2 Every Lift Inspection**

An inspection must be performed on the following girder clamp items before and/or during every lift for any indication of damage. This includes observations for any damage during operation.

1. Ensure that the plate surface with which the clamp is to come into contact is free of scale, grease, oil paint, water, ice, moisture, dirt and coatings that might impede the contact of the gripping surface with the load.
2. Check that the working load sticker on the girder clamp corresponds with the load to be lifted.
3. Ensure that the jacking threaded rod is well greased.
4. Check for any cracks, deformation or excessive wear on the components.

### **7.3 Frequent Inspection**

On girder clamps in continuous service, frequent inspection should be made at the beginning of each shift. In addition, visual inspections should be conducted during regular service for any damage or evidence of malfunction. The following must be inspected on the girder clamp during each inspection:

1. Side plates, hang bar, jacking threaded rod, trunnions, support pins and clamp handle require inspection for deformation, cracks or excessive wear.
2. Check the jacking threaded rod for its function by opening and closing the clamp (when the operation of the clamp is stiff or heavy, it should be removed from operation).
3. Loose or missing warning stickers or nameplates.

### **7.4 Periodic Inspection**

Frequency of periodic inspection depends on the severity of usage:

NORMAL	HEAVY	SERVERE
Yearly	Biannually	Quarterly

A complete inspection of the clamp shall be performed at intervals as defined above. Any deficiencies, such as

listed below, shall be examined and determination made as to whether they constitute a hazard.

1. Side plates, hang bar, jacking threaded rod, trunnions, support pins and clamp handle require inspection for deformation, cracks or excessive wear.
2. Check the jacking threaded rod for its function by opening and closing the clamp (when the operation of the clamp is stiff or heavy, it should be removed from operation).
3. Loose or missing warning stickers or nameplates.

#### 7.4.1 Records and Reports

An inspection record should be maintained for each girder clamp, listing all points requiring periodic inspection. A written report should be made monthly on the condition of the critical parts of each girder clamp. These reports should be dated, signed by each person who performed the inspection, and kept on file where they are readily available to authorized personnel.

### 7.5 Daily Inspection for Machines Operated in Corrosive Environments

If the machine operating environment is at all corrosive, a more in depth daily inspection should be undertaken; jacking threaded rod should be well greased.

### 7.6 Girder Clamp Not in Regular Use

1. A girder clamp which has been idle for a period of one month or more, but less than one year, should be given an inspection conforming with the requirements for "Frequent Inspection" prior to being placed into service.
2. A girder clamp which has been idle for a period of more than one year should be given an inspection conforming with the requirements of "Periodic Inspection" prior to being placed into service.
3. Standby girder clamp should be inspected at least biannually in accordance with the requirement of "Frequent Inspection". In abnormal operating conditions girder clamps should be inspected at shorter intervals.

## 8 Operation

### 8.1 Rules for the Safe Operation of Girder Clamps

In addition to the rules listed under section "Initial Operation" the following rules have to be observed:

If several girder clamps are working together, the customer has to set up the conditions for safe operation.

If the local conditions or the work to be performed make it necessary, the customer has to define operating instructions.

Maintenance and inspection work may only be performed once the people in charge are convinced that the girder clamp is not under load and has been unmounted from the girder.

If components other than Elephant Lifting Products components are used, danger may occur. Such an application can only be allowed after having received Elephant Lifting Products agreement.

### 8.2 Operating Limits of the Girder Clamp



Before using the girder clamp. The beam should be tested by an expert or the manufacturer of the beam to check that it is suitable for use with the beam clamp.



Do not load the girder clamp at an angle in the same plane as the direction of the length of the beam. Only loading perpendicular to the length of the beam is permitted. Refer to the figures below for more information on the correct and incorrect method of loading the girder clamp.



Incorrect: These clamps are not suitable for side loading as they are of light weight design.

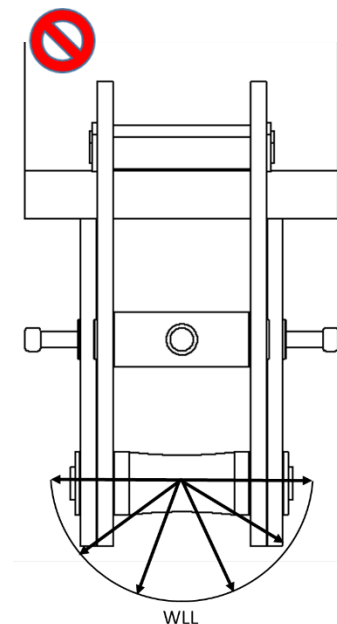



Correct:

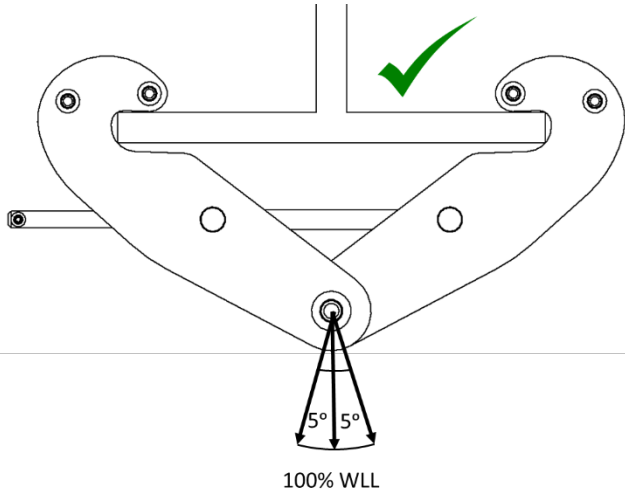

## 9 Maintenance

### 9.1 Maintenance and Inspection Intervals

Elephant Lifting Products girder clamps are extremely robust and require little maintenance. Compliance with maintenance and inspection intervals is of great importance, in order that the girder clamps operate safely and reliably over a period of many years. If the girder clamp is being operated in a harsh environment that leads to accelerated wear, then the intervals should be reduced.

### CAUTION

Maintenance work on Elephant Lifting Products girder clamps must only be performed by trained and qualified personnel.

In the case of maintenance work exceeding normal service and maintenance, please contact Elephant Lifting Products .

### 9.2 Cleaning and Care

If your Elephant Lifting Products girder clamp has to work in dirty surroundings, remove coarse dirt from the clamp and grease jacking threaded rod.

### 9.3 Spare Parts

There are no spare parts available for the Elephant Lifting Products girder clamps and therefore if repairing is required the girder clamp must be replaced.

### NOTICE

- Please note the requirements of the Occupational Health and Safety Act of South Africa (Act 85 of 1993), Driven Machinery (Regulation 18) Lifting Machines and Lifting Tackle regarding the examination and testing of lifting machines and lifting tackle.

## 10 Technical Data

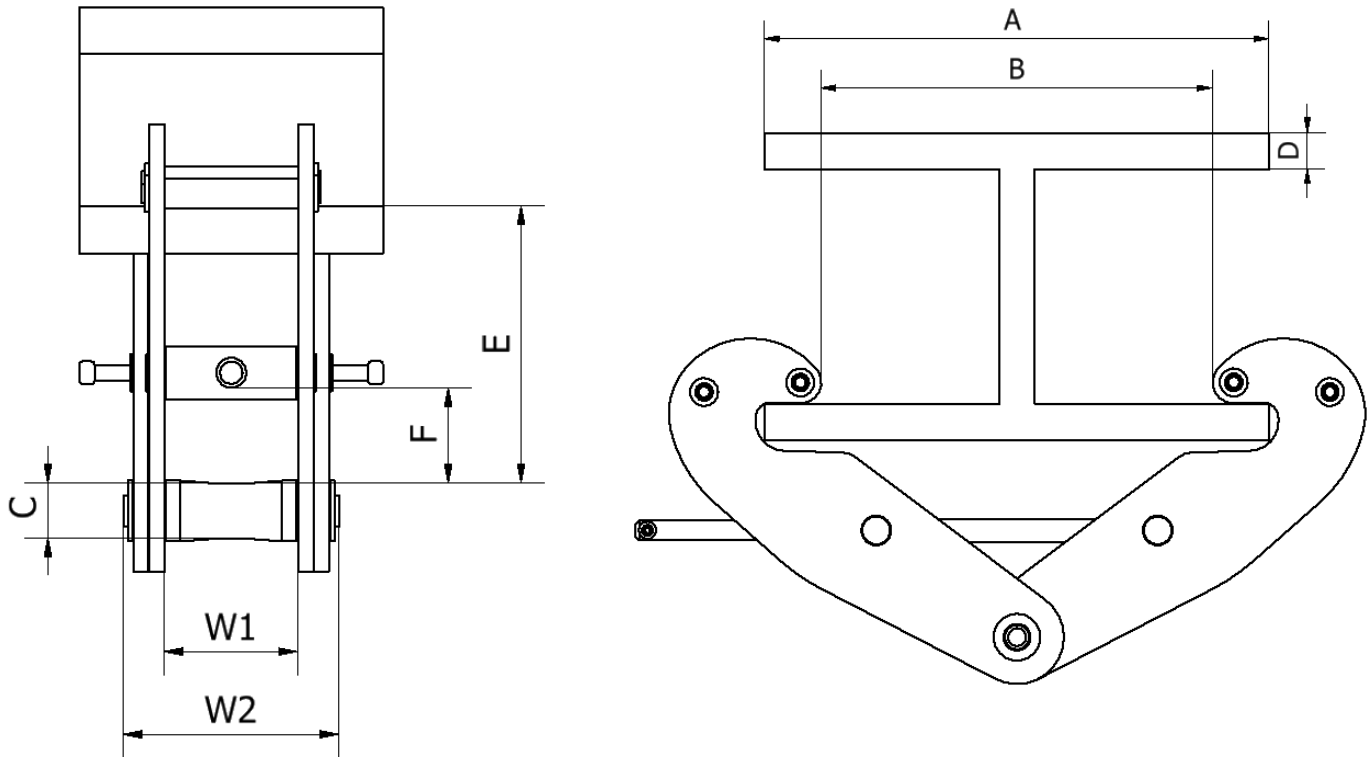

MODEL	S.W.L (kg)	S.W.L (lbs)	APERATURE (in)		WIDTH (in)		"C" (in)	WEIGHT (lbs)	"D" Beam Aperature (in)	"E" (in)	"F" (in)
			"A"	"B" MAX	W1	W2					
GS-2	2000	4400	2.9-9.8	9.8	2.5	3.9	0.87	10	0.7	4.02-5.56	1.20-2.38
GS-3	3000	6600	3.3-11.8	11.8	2.8	4.7	1	17.5	0.9	4.99-6.81	1.62-3.03
GS-5	5000	11000	4.7-16.9	16.9	3.3	5.6	1.3	36	1.2	7.24-9.79	2.63-4.62
GS-5-SS	5000	11000	4.7-16.10	16.9	3.4	5.6	1.4	37	1.2	7.12-9.75	2.47-4.53
GS-10	10000	22000	7.8-17.7	17.7	4.1	7.3	1.8	73	2.3	8.17-10.57	2.59-4.31
GS-20	20000	44000	7.8-18.9	18.9	4.7	9.3	2.4	141	2.7	9.16-11.42	3.40-5.24
GS-32	32000	70500	9.0-30.0	30	9	14.4	3.4	313	3.1	13.4-17.77	6.13-10.4



Elephant Lifting Products, LLC

Distributed by Ergonomic Partners  
Sales@ErgonomicPartners.com  
www.ErgonomicPartners.com  
Tel: 314-884-8884