

MRX Wiring Diagram

PUSH BUTTON 1~2

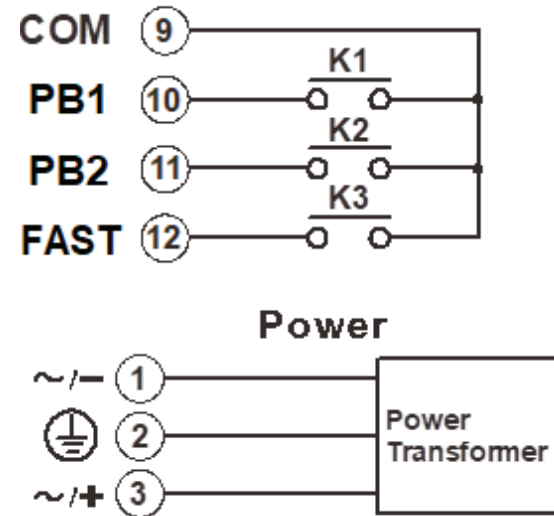

MAIN / FUNC

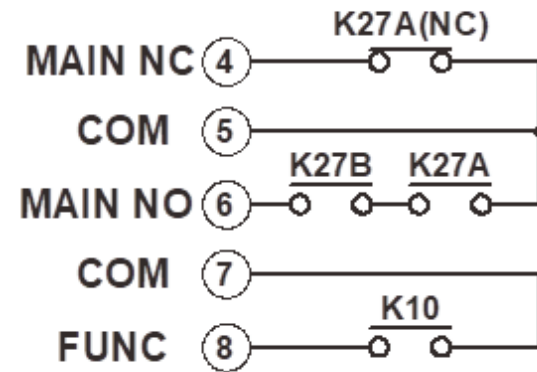

- In the single speed model, relay K1 is for PB1 and relay K2 is for PB2.
- Relay K3 is not used in the single speed model.
- In the dual speed model, relay K1 is first speed for PB1, relay K2 is first speed for PB2, and relay K3 is shared as a second speed for PB1 and PB2.

Relay	PB1 2 ND Speed	PB1 1 ST Speed	OFF	PB2 1 ST Speed	PB2 2 ND Speed
K1	X	X			
K2				X	X
K3	X				X

- MAIN Relays K27A(NC), K27A and K27B change state when the system is turned on and remain latched while the system is turned on. When the system is turned off, these relays revert to their normal state.
- FUNC Relay K10 is an auxiliary relay that closes during the START / ON sequence and opens when PB1 and PB2 are released.
- For 9-36VDC power supply, wire #1 corresponds to the negative charge (-), wire #3 corresponds to the positive charge (+), and wire #2 is for GROUND.
- The circled numbers in the output diagrams above correspond to the wire numbers in the harness.
- Suppressors are recommended on contactors being driven by Flex relays due to the possibility of voltage spikes.



Flex Duo™ Radio Control Equipment Quick Reference Manual

NOTE: The full Flex Duo Instruction Manual can be found at www.columbusmckinnon.com/magnetek. Consult the Instruction Manual for any desired feature not included in this quick reference manual.



MAGNETEK

191-32000-M001 R00
September 2020
© Copyright 2020 Magnetek

General Operating Procedures

The Flex Duo system consists of the transmitter(s) and receiver containing all of the required settings to work upon quick installation.

The default operation of the Flex Duo system has the two pushbuttons configured as an interlocked pair to perform as motion control with the corresponding output relays setup for momentary contact closure. Pressing both buttons at the same time after start-up will result in no output because the buttons are configured as interlocked.

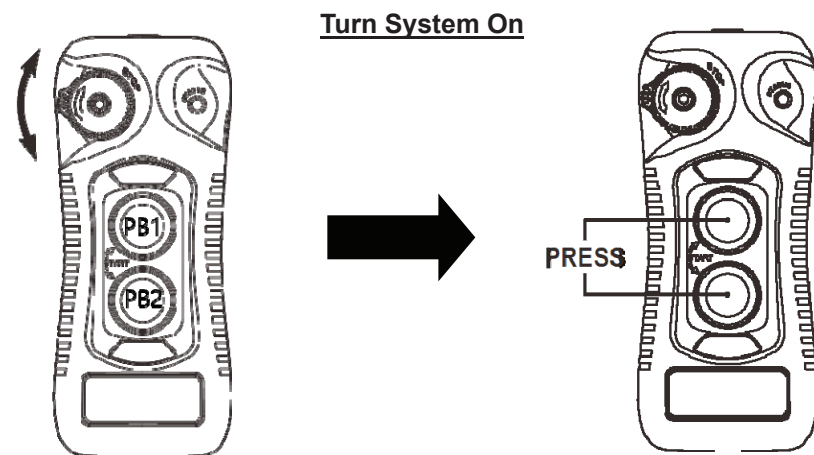

1. Install the provided batteries in the transmitter and power on the receiver.
2. Elevate the STOP button to power on the transmitter.
3. Perform the START command by pressing and holding both PB1 and PB2 at the same time for 1 second to activate the receiver MAIN relays and to establish a communication link with the receiver.

When the receiver MAIN relays are activated, the Status LED will change from constant green to constant orange (system on). Press any pushbutton on the transmitter to begin operation. Pressing any pushbutton prior to executing the START command at startup will result in no signals transmitted (Status LED blinks orange).

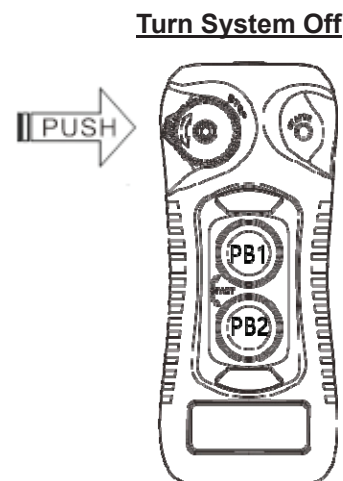

Press the STOP button down to power off the transmitter, disconnect the receiver MAIN relays, and to disconnect the communication link with the receiver.

After 5 minutes of inactivity (pushbutton not pressed), the receiver MAIN relays are temporarily disconnected. The Status LED blinks 3 reds and then shuts off. Press any pushbutton to resume operation.

Receiver Installation

The Flex Duo factory setting uses an internal antenna. If an external antenna kit is required, ensure the MCX antenna cable located on the RF/decoder board inside the receiver is connected and the jumper is moved from the INT to the EXT position.

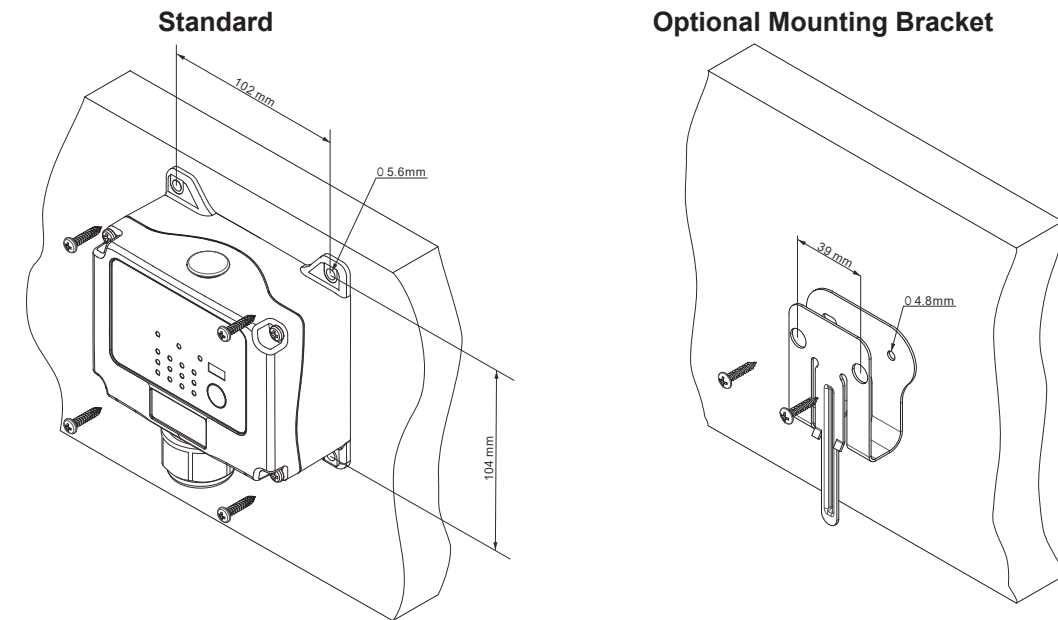
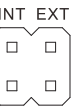

For best reception, the receiver and/or external antenna should always be mounted in a location with a clear line of sight to the transmitter. Ensure the mounting location of the receiver is not exposed to high levels of electric noise. Mounting the receiver next to a variable frequency drive or an EMI / RFI generator may cause radio interference.

Once the proper mounting location is identified, drill four holes (standard) or two holes (optional mounting bracket) on the control panel, wall, or location where the receiver is to be installed.

If a mounting bracket is used, leave enough slack in the harness to accommodate sliding the receiver on and off the bracket.

