

120VAC – 240VAC STEP-UP CONFIGURATION

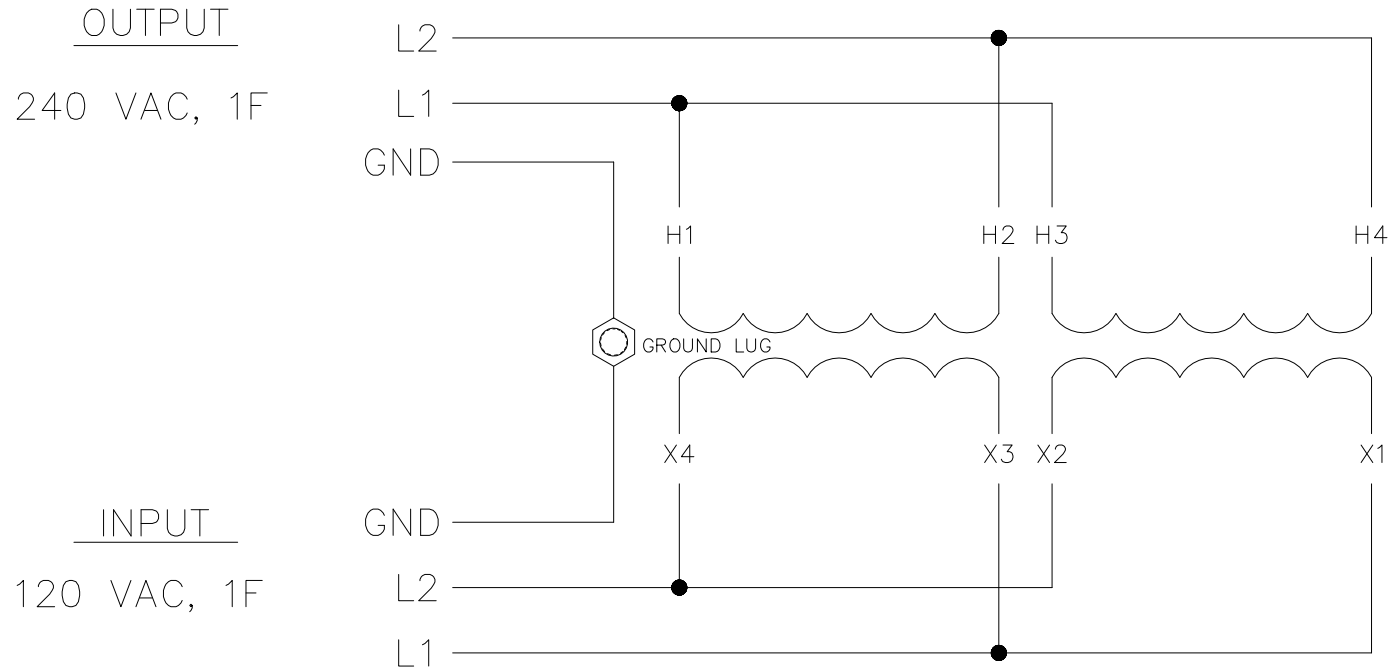

NOTE 1: THE ABOVE WIRING REFLECTS THE PROPER CONFIGURATION FOR 120-240 STEP-UP ONLY.

NOTE 2: THE ABOVE ASSUMES THE USE OF ACME #T-2-53011-S.

THIS DRAWING EMBODIES A CONFIDENTIAL PROPRIETARY DESIGN ORIGINATED BY GORBEL INC. AND ALL DESIGN, MANUFACTURING, REPRODUCTION, USE, AND SALES RIGHTS REGARDING THE SAME ARE EXPRESSLY RESERVED. IT IS SUBMITTED UNDER A CONFIDENTIAL RELATIONSHIP FOR A SPECIFIC PURPOSE, AND THE RECIPIENT AGREES BY ACCEPTING THIS DRAWING NOT TO SUPPLY OR DISCLOSE ANY INFORMATION REGARDING IT TO ANY UNAUTHORIZED PERSON, OR TO INCORPORATE IN OTHER PROJECTS ANY SPECIAL FEATURES PECULIAR TO THIS DESIGN. ALL PATENT RIGHTS HERETO ARE EXPRESSLY RESERVED BY GORBEL INC., FISHERS, NY.

UNLESS OTHERWISE SPECIFIED
ALL DIMENSIONS ARE IN INCHES
BREAK ALL SHARP EDGES .010 MAXIMUM
CONFORMANCE TO STANDARDS: ASME Y14.5M ANSI/AWS D14.1
<u>TOLERANCE</u>
1/X ± 1/16
.XX ± .010
.XXX ± .005
X° ± 1°

GORBEL

600 FISHERS RUN
P.O. BOX 593
FISHERS, N.Y. 14453-0593

TITLE: TRANSFORMER WIRING
MAT'L: STEP-UP CONFIGURATION

DWN. BY: BBL DATE: 3/7/01

W.O.# P/N: 78100.WIRING.UP

QTY.

480VAC – 240VAC STEP-DOWN CONFIGURATION

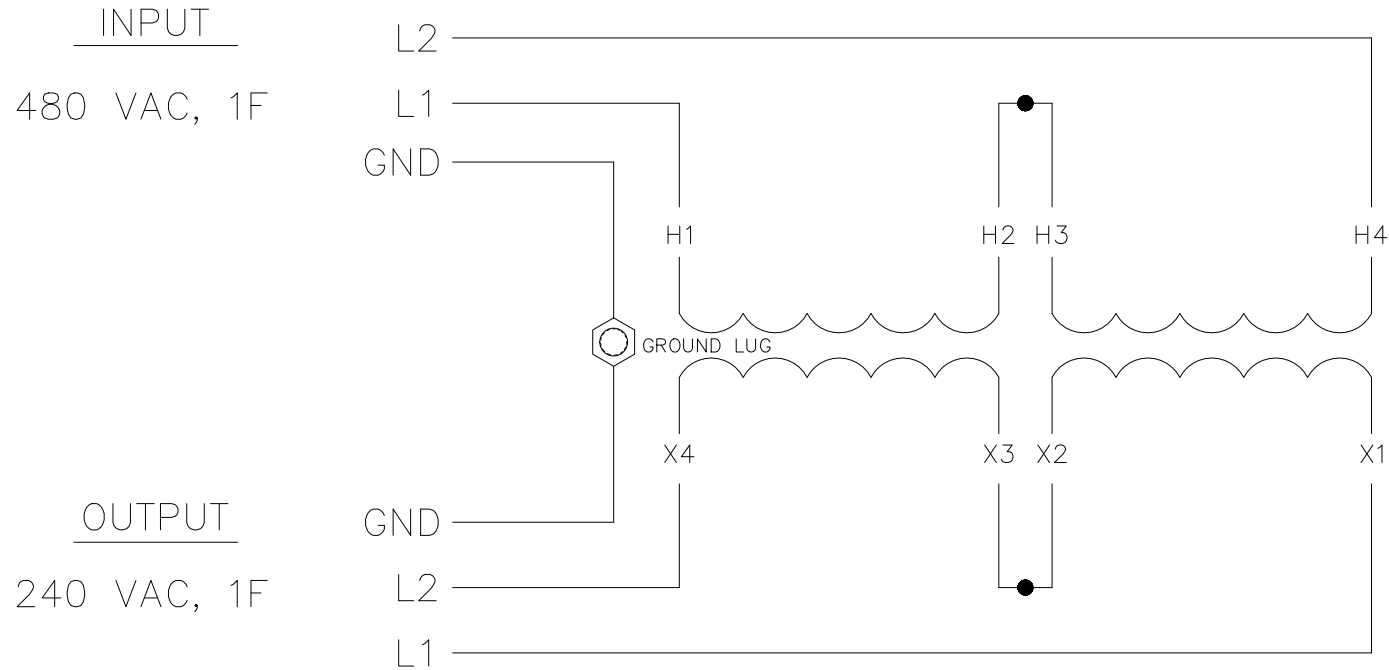

NOTE 1: THE ABOVE WIRING REFLECTS THE PROPER CONFIGURATION FOR 480-240 STEP-DOWN ONLY.

NOTE 2: THE ABOVE ASSUMES THE USE OF ACME #T-2-53011-S.

THIS DRAWING EMBODIES A CONFIDENTIAL PROPRIETARY DESIGN ORIGINATED BY GORBEL INC. AND ALL DESIGN, MANUFACTURING, REPRODUCTION, USE, AND SALES RIGHTS REGARDING THE SAME ARE EXPRESSLY RESERVED. IT IS SUBMITTED UNDER A CONFIDENTIAL RELATIONSHIP FOR A SPECIFIC PURPOSE, AND THE RECIPIENT AGREES BY ACCEPTING THIS DRAWING NOT TO SUPPLY OR DISCLOSE ANY INFORMATION REGARDING IT TO ANY UNAUTHORIZED PERSON, OR TO INCORPORATE IN OTHER PROJECTS ANY SPECIAL FEATURES PECULIAR TO THIS DESIGN. ALL PATENT RIGHTS HERETO ARE EXPRESSLY RESERVED BY GORBEL INC., FISHERS, NY.

UNLESS OTHERWISE SPECIFIED
ALL DIMENSIONS ARE IN INCHES
BREAK ALL SHARP EDGES .010 MAXIMUM
CONFORMANCE TO STANDARDS: ASME Y14.5M ANSI/AWS D14.1
<u>TOLERANCE</u>
1/X ± 1/16
.XX ± .010
.XXX ± .005
X° ± 1°

GORBEL

600 FISHERS RUN
P.O. BOX 593
FISHERS, N.Y. 14453-0593

TITLE: TRANSFORMER WIRING
MAT'L: STEP-DOWN CONFIGURATION

DWN. BY: BBL DATE: 3/7/01

QTY. W.O.# P/N: 78100.WIRING.DOWN