

INSTRUCTIONS AND PARTS LIST
CRANE BRIDGE KITS
CATALOG NUMBERS 904535, 904536 & 904538
PUSH, HAND GEARED AND MOTOR DRIVEN

TO BUILD TOP RUNNING CRANE BRIDGES

THE INFORMATION CONTAINED IN THIS MANUAL IS FOR INFORMATIONAL PURPOSES ONLY AND COLUMBUS MCKINNON CORPORATION DOES NOT WARRANT OR OTHERWISE GUARANTEE (IMPLIEDLY OR EXPRESSLY) ANYTHING OTHER THAN THE COMPONENTS THAT COLUMBUS MCKINNON CORPORATION MANUFACTURES AND ASSUMES NO LEGAL RESPONSIBILITY (INCLUDING, BUT NOT LIMITED TO CONSEQUENTIAL DAMAGES) FOR INFORMATION CONTAINED IN THIS MANUAL.

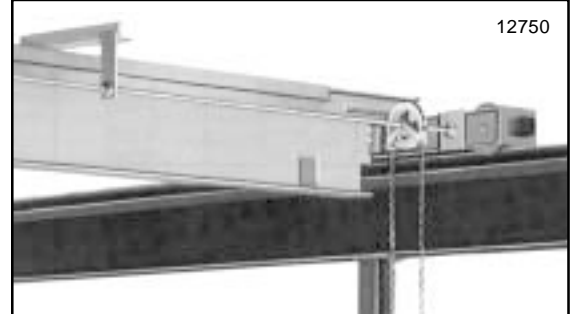

Figure 1.

GENERAL

These crane bridge kits contain all parts needed, except the bridge beam, cross shaft (when required), and the trolley stop angles to build top running, single girder crane bridges in rated loads and spans (center-to-center distance between runway beams) charted below.

GIRDER SELECTION TABLE - S BEAMS

(**) BEAM SIZES FOR VARIOUS SPANS									
Spans To	(*) RATED LOAD IN TONS OF 2000#								Spans To
	1/4	1/2	1	1-1/2	2	3	4	5	
Push or Hand Geared Crane - 54" Wheelbase									
10 ft.	S 6x12.5	S 6x12.5	S 6x12.5	S 8x18.4	S 10x25.4	S 12x40.8	S 12x40.8	S 12x40.8	10 ft.
12 ft.	S 6x12.5	S 6x12.5	S 7x15.3	S 10x25.4	S 10x25.4	S 12x40.8	S 12x40.8	S 18x54.7	12 ft.
14 ft.	S 6x12.5	S 6x12.5	S 7x15.3	S 10x25.4	S 12x31.8	S 12x40.8	S 12x40.8	S 18x54.7	14 ft.
16 ft.	S 6x12.5	S 7x15.3	S 8x18.4	S 10x25.4	S 12x31.8	S 12x40.8	S 12x40.8	S 18x54.7	16 ft.
18 ft.	S 7x15.3	S 7x15.3	S 10x25.4	S 10x25.4	S 12x31.8	S 12x40.8	S 15x42.9	S 18x54.7	18 ft.
20 ft.	S 7x15.3	S 8x18.4	S 10x25.4	S 12x31.8	S 12x31.8	S 12x40.8	S 18x54.7	S 18x54.7	20 ft.
22 ft.	S 8x18.4	S 10x25.4	S 10x25.4	S 12x31.8	S 12x40.8	S 18x54.7	S 18x54.7	S 20x66	22 ft.
24 ft.	S 8x18.4	S 10x25.4	S 12x31.8	S 12x40.8	S 12x40.8	S 18x54.7	S 18x54.7	S 20x66	24 ft.
26 ft.	S 10x25.4	S 10x25.4	S 12x31.8	S 12x40.8	S 15x42.9	S 18x54.7	S 20x66	S 24x80	26 ft.
28 ft.	S 10x25.4	S 10x25.4	S 12x40.8	S 12x40.8	S 18x54.7	S 20x66	S 20x66	S 24x80	28 ft.
30 ft.	S 10x25.4	S 12x31.8	S 12x40.8	S 18x54.7	S 18x54.7	S 20x66	S 18x54.7 w/C 9x13.4	S 24x80	30 ft.
32 ft.	S 10x25.4	S 12x31.8	S 12x40.8	S 18x54.7	S 15x42.9 w/C 8x11.5	S 18x54.7 w/C 9x13.4	S 18x54.7 w/C 9x13.4	S 20x66 w/C 9x13.4	32 ft.
34 ft.	S 12x31.8	S 12x40.8	S 15x42.9	S 18x54.7	S 15x42.9 w/C 8x11.5	S 18x54.7 w/C 9x13.4	S 18x54.7 w/C 9x13.4	S 20x66 w/C 9x13.4	34 ft.
36 ft.	S 12x31.8	S 12x40.8	S 18x54.7	S 15x42.9 w/C 8x11.5	S 15x42.9 w/C 8x11.5	S 18x54.7 w/C 9x13.4	S 20x66 w/C 9x13.4	S 20x66 w/C 9x13.4	36 ft.
Motor Driven Crane - 54" Wheelbase									
10 ft.	S 6x12.5	S 6x12.5	S 6x12.5	S 10x25.4	S 10x25.4	S 12x40.8	S 12x40.8	S 12x40.8	10 ft.
12 ft.	S 6x12.5	S 6x12.5	S 7x15.3	S 10x25.4	S 12x31.8	S 12x40.8	S 12x40.8	S 18x54.7	12 ft.
14 ft.	S 6x12.5	S 6x12.5	S 7x15.3	S 10x25.4	S 12x31.8	S 12x40.8	S 12x40.8	S 18x54.7	14 ft.
16 ft.	S 6x12.5	S 7x15.3	S 8x18.4	S 10x25.4	S 12x31.8	S 12x40.8	S 18x54.7	S 18x54.7	16 ft.
18 ft.	S 7x15.3	S 8x18.4	S 10x25.4	S 12x31.8	S 12x31.8	S 18x54.7	S 18x54.7	S 20x66	18 ft.
20 ft.	S 7x15.3	S 8x18.4	S 10x25.4	S 12x31.8	S 12x40.8	S 18x54.7	S 18x54.7	S 20x66	20 ft.
22 ft.	S 8x18.4	S 10x25.4	S 12x31.8	S 12x40.8	S 12x40.8	S 18x54.7	S 20x66	S 20x66	22 ft.
24 ft.	S 10x25.4	S 10x25.4	S 12x31.8	S 12x40.8	S 18x54.7	S 20x66	S 20x66	S 24x80	24 ft.
26 ft.	S 10x25.4	S 10x25.4	S 12x40.8	S 18x54.7	S 18x54.7	S 20x66	S 18x54.7 w/C 9x13.4	S 24x80	26 ft.
28 ft.	S 10x25.4	S 12x31.8	S 12x40.8	S 18x54.7	S 12x40.8 w/C 8x11.5	S 18x54.7 w/C 9x13.4	S 18x54.7 w/C 9x13.4	S 20x66 w/C 9x13.4	28 ft.
30 ft.	S 10x25.4	S 12x31.8	S 12x40.8	S 18x54.7	S 12x40.8 w/C 8x11.5	S 18x54.7 w/C 9x13.4	S 18x54.7 w/C 9x13.4	S 20x66 w/C 9x13.4	30 ft.
32 ft.	S 12x31.8	S 12x40.8	S 18x54.7	S 12x40.8 w/C 8x11.5	S 15x42.9 w/C 8x11.5	S 18x54.7 w/C 9x13.4	S 18x54.7 w/C 10x15.3	S 20x66 w/C 9x13.4	32 ft.
34 ft.	S 12x40.8	S 12x40.8	S 18x54.7	S 15x42.9 w/C 8x11.5	S 15x42.9 w/C 8x11.5	S 18x54.7 w/C 9x13.4	S 20x66 w/C 9x13.4	S 20x66 w/C 9x13.4	34 ft.
36 ft.	S 12x40.8	S 12x40.8	S 12x31.8 w/C 9x13.4	S 15x42.9 w/C 8x11.5	S 15x42.9 w/C 8x11.5	S 18x54.7 w/C 20x20.7	S 20x66 w/C 9x13.4	S 20x66 w/C 12x20.7	36 ft.

* Rated load is based on maximum combined hoist and trolley weights of: 500 pounds for 1/4, 1/2 and 1 ton hoists; 1100 pounds for 1 1/2 and 2 ton hoists; 1600 pounds for 3 and 4 ton hoists; 2000 pounds for 5 ton hoists. Bridge designed in accordance with latest edition of CMAA Specification No. 74, using Lift-Tech trolleys.

** Beam sizes listed are American Standard I-Beam and Channel sections. Use ASTM A36 grade steel, first quality, free of rust and excessive mill scale.

GIRDER SELECTION TABLE - WIDE FLANGE BEAMS

(**) BEAM SIZES FOR VARIOUS SPANS									
Spans To	(*) RATED LOAD IN TONS OF 2000#							Spans To	
	1/4	1/2	1	1-1/2	2	3	4		5
Push or Hand Geared Crane - 54" Wheelbase									
10 ft.	W 6x12	W 6x12	W 8x15	W 10x19	W 12x22	W 10x30	W 14x38	W 18x46	10 ft.
12 ft.	W 6x12	W 6x12	W 8x15	W 10x19	W 12x22	W 12x35	W 18x40	W 18x46	12 ft.
14 ft.	W 6x12	W 6x12	W 8x15	W 10x19	W 10x26	W 12x35	W 18x40	W 18x46	14 ft.
16 ft.	W 6x12	W 8x15	W 8x18	W 10x26	W 14x26	W 14x38	W 16x45	W 16x50	16 ft.
18 ft.	W 8x15	W 8x18	W 8x18	W 10x26	W 10x30	W 18x40	W 16x45	W 18x55	18 ft.
20 ft.	W 8x15	W 8x18	W 8x21	W 10x26	W 10x30	W 18x40	W 18x46	W 16x57	20 ft.
22 ft.	W 8x18	W 8x18	W 10x26	W 10x30	W 14x34	W 12x45	W 16x50	W 16x57	22 ft.
24 ft.	W 8x18	W 8x21	W 10x26	W 10x30	W 12x35	W 16x45	W 16x50	W 16x57	24 ft.
26 ft.	W 8x21	W 10x22	W 10x30	W 12x35	W 14x38	W 14x48	W 14x53	W 18x60	26 ft.
28 ft.	W 10x22	W 10x26	W 10x30	W 14x38	W 12x40	W 14x48	W 16x57	W 18x65	28 ft.
30 ft.	W 10x22	W 10x26	W 14x34	W 12x40	W 14x43	W 14x53	W 18x65	W 18x71	30 ft.
32 ft.	W 10x26	W 10x30	W 12x35	W 14x43	W 14x48	W 18x60	W 16x67	W 16x77	32 ft.
34 ft.	W 10x26	W 12x30	W 14x38	W 14x48	W 14x48	W 18x65	W 16x67	W 16x77	34 ft.
36 ft.	W 10x30	W 14x34	W 12x40	W 14x48	W 14x53	W 16x67	W 16x77	W 16x89	36 ft.
Motor Driven Crane - Single Drive - 36" and 54" Wheelbase									
10 ft.	W 6x12	W 6x12	W 8x15	W 10x19	W 12x22	W 12x35	W 18x40	W 18x46	10 ft.
12 ft.	W 6x12	W 6x12	W 8x15	W 10x19	W 10x26	W 12x35	W 18x40	W 18x46	12 ft.
14 ft.	W 6x12	W 6x12	W 8x18	W 10x26	W 14x26	W 14x38	W 10x45	W 16x50	14 ft.
16 ft.	W 6x12	W 8x15	W 8x18	W 10x26	W 10x30	W 18x40	W 16x45	W 14x53	16 ft.
18 ft.	W 8x15	W 8x18	W 8x21	W 10x26	W 10x30	W 18x40	W 18x46	W 16x57	18 ft.
20 ft.	W 8x18	W 8x18	W 8x21	W 10x30	W 10x30	W 10x45	W 12x50	W 16x57	20 ft.
22 ft.	W 8x18	W 8x21	W 10x26	W 10x30	W 12x35	W 16x45	W 16x50	W 16x57	22 ft.
24 ft.	W 8x18	W 8x21	W 10x26	W 14x34	W 14x38	W 14x48	W 14x53	W 18x65	24 ft.
26 ft.	W 8x21	W 10x26	W 10x30	W 12x35	W 12x40	W 12x50	W 16x57	W 18x65	26 ft.
28 ft.	W 10x22	W 10x26	W 10x33	W 12x40	W 12x40	W 14x53	W 18x65	W 18x71	28 ft.
30 ft.	W 10x26	W 10x30	W 12x35	W 12x40	W 12x45	W 14x53	W 16x67	W 14x74	30 ft.
32 ft.	W 10x26	W 10x30	W 14x38	W 12x45	W 14x48	W 14x61	W 16x67	W 16x77	32 ft.
34 ft.	W 10x30	W 14x34	W 12x40	W 14x48	W 14x53	W 16x67	W 16x67	W 16x89	34 ft.
36 ft.	W 10x30	W 12x35	W 12x40	W 14x53	W 14x61	W 16x67	W 16x77	W 16x89	36 ft.
Motor Driven Crane - Dual Drive - 72" Wheelbase									
38 ft.	W12x35	W12x40	W14x48	W14x61	W16x67	W16x77	W16x89	W18x97	38 ft.
40 ft.	W12x40	W12x45	W14x53	W16x67	W16x67	W16x89	W18x86	W21x101	40 ft.
42 ft.	W12x40	W14x48	W14x61	W16x67	W16x67	W18x86	W18x97	W21x101	42 ft.
44 ft.	W14x43	W14x48	W14x61	W16x67	W16x77	W18x86	W21x101	W21x111	44 ft.
46 ft.	W14x48	W14x53	W16x67	W16x77	W18x76	W18x97	W21x101	W21x111	46 ft.
48 ft.	W14x53	W14x61	W16x67	W18x76	W18x86	W21x101	W21x111	W21x122	48 ft.

* Rated load is based on maximum combined hoist and trolley weights of: 500 pounds for 1/4, 1/2 and 1 ton hoists; 1100 pounds for 1½ and 2 ton hoists; 1600 pounds for 3 and 4 ton hoists; 2000 pounds for 5 ton hoists. Bridge designed in accordance with latest edition of CMAA Specification No. 74, using Lift-Tech trolleys.

** Beam sizes listed are American Standard Wide Flange Beam sections. Use ASTM A36 grade steel, first quality, free of rust and excessive mill scale.

Catalog Number Required to Build a Push Crane Bridge

For Spans Thru (ft)	Rated Load Range (tons)	1 Pair of End Trucks (Catalog Number)
36	1/4 thru 5	904535

Catalog Numbers Required to Build a Hand Geared Crane Bridge

For Spans Thru (ft)	Rated Load Range (tons)	1 Pair of End Trucks (Cat. No. 904536)	Chain Wheel & Guide* (Cat. No. 904539)	Hand Chain** (Cat No. 8282)	Cross Shaft Support		Cross Shaft Coupling	
		Catalog Number			Number Req'd	Catalog Number	Number Req'd	Catalog Number
8	1/4 thru 5	904538			0	904540	0	905374
15					0		0	
22					1		0	
29					2		1	
36					3		1	

* Includes one Cross Shaft Support and two Cross Shaft Couplings.

** 36 feet of Hand Chain.

Catalog Numbers Required to Build a Motor Driven Single Drive Crane Bridge

For Spans Thru (ft)	Rated Load Range (tons)	1 Pair of End Trucks (Catalog Number)	Cross Shaft Support		Cross Shaft Coupling		Gear Reducer			Motor		Control			Fused Disconnect Switch	
			Number Req'd	Catalog Number	Number Req'd	Catalog Number	10:1 Ratio (101 fpm)	15:1 Ratio (67 fpm)	20:1 Ratio (51 fpm)	208-230/460V	575V	208-230V	460V	575V	208-230V	460-575V
8	1/4 thru 5	904536	0	904540	2	905374	905376	905377	905378	905381	905382	904541	904542	904543	905388	905389
15			1		2											
22			2		2											
29			3		3											
36			4		3											

Catalog Numbers Required for Optional Equipment

Two Speed Motors and Controls

Motor			115V Control		
208-230V	460V	575V	208-230V	460V	575V
905394	905395	905396	904546	904547	904548

Single Phase Motors and Controls

Motor	115V Control	
120-240V	120V	240V
905363	904544	904545

Ballast Resistors		
208-230V	460V	575V
905391	905392	905393

Electronic Acceleration Control (208-230-460/3/60)	
Single Speed	904596
Two Speed	904598

Voltage	Switch
208-230/3/60	905338
460-575/3/60	905389
120/1/60	905366
240/1/60	905367

Bridge Brake

Voltage	Brake
120-240/1/60	905554
230-460/1/60	905555
575/3/60	905556

Bridge Bumpers	932000
----------------	--------

Air Motor Drive Package	904558
-------------------------	--------

Girder Connection Kits

Bolted Uncoped Girder - 54" WB	912099
Bolted Uncoped Girder - 72" WB	912102
Coped Girder	912101

Catalog Numbers Required to Build a Motor Driven Dual Drive Crane Bridge

Max. Capacity (tons)	Max. Span (ft)	Speed (fpm)	Rail Size (# / yd)	Kit Consists of				Approximate Shipping Weight (lbs)	
				Kit Code Number	End Truck Code Number	Gear Reducer (Qty. 2)	Controls & Motor	1 Speed	2 Speed
5	36	50	25 to 40	B05/36TD*50	904536 4' - 6" WB	905378	1 each Control 2 each 1/2 hp Motor 1 each Disconnect (See Below)	575	615
		70		B05/36TD*70		905377			
		100		B05/36TD*100		905376			
	48	50	40	Not Available					
		70		B05/48TD*70	904549	905377	1 each Control 2 each 3/4 hp Motor 1 each Disconnect (See Below)	675	715
		100		B05/48TD*100	6' - 0" WB	905376			

* Insert 1 for Single Speed or 2 for Two Speed

Motors and Controls - Motor Driven - Dual Drive Top Running Cranes

Max. Span (ft)	Travel Speed (fpm)	No. of Speeds	200 - 208 Volt Power			230 Volt Power		
			Motor 2 Req'd	Control 1 Req'd	Disconnect Switch 1 Req'd	Motor 2 Req'd	Control 1 Req'd	Disconnect Switch 1 Req'd
36	50, 70 and 100	Single	1/2 hp 905381	44600326	905388	1/2 hp 905381	44600326	905388
		Two	1/2 hp 32879624	44600336	905388	1/2 hp 905394	44600336	905388
48	50	-	Not Available			Not Available		
	70	Single	1/2 hp 905381	44600326	905388	1/2 hp 905381	44600326	905388
		Two	1/2 hp 32879624	44600336	905388	1/2 hp 905394	44600336	905388
	100	Single	3/4 hp 32879542	44600329	905388	3/4 hp 32879542	44600329	905388
		Two	3/4 hp 32879643	44600339	905388	3/4 hp 32879635	44600339	905388

Max. Span (ft)	Travel Speed (fpm)	No. of Speeds	460 Volt Power			575 Volt Power		
			Motor 2 Req'd	Control 1 Req'd	Disconnect Switch 1 Req'd	Motor 2 Req'd	Control 1 Req'd	Disconnect Switch 1 Req'd
36	50, 70 and 100	Single	1/2 hp 905381	44600383	905389	1/2 hp 905382	44600384	905389
		Two	1/2 hp 905395	44600393	905389	1/2 hp 905396	44600394	905389
48	50	-	Not Available			Not Available		
	70	Single	1/2 hp 905381	44600383	905389	1/2 hp 905382	44600384	905389
		Two	1/2 hp 905395	44600393	905389	1/2 hp 905396	44600394	905389
	100	Single	3/4 hp 32879542	44600327	905389	3/4 hp 32879543	44600328	905389
Two		3/4 hp 32879636	44600337	905389	3/4 hp 32879637	44600338	905389	

The proper catalog numbers must be ordered to build the crane required. For a push crane only one catalog number is required. Three are required for a hand geared crane, seven are required for a single motor driven crane and five are required for a dual drive motor driven crane. Options are also available. Catalog numbers are shown on pages 2 and 3.

End trucks have 8" diameter wheels. Minimum recommended runway rail is ASCE 20#. Maximum size runway rail for minimum CMAA Specification No. 74 float of 3/4" is ASCE 45#. Maximum permissible rail size is ASCE 60# with a reduced float of 3/8". Width between wheel flanges is 2-3/4".

NOTICE

When installing crane on existing runways, make sure rails are straight and parallel within tolerances shown below. Reposition rail if necessary.

Runway beams must be properly designed to support bridge, hoist, trolley and rated load. Runway rails must be level and parallel within ± 1/8". Maximum slope of runway must not be more than 1/16" in 1 foot. Rail separation at joints should not exceed 1/32". Runway stops must be positioned to contact both ends of the crane simultaneously.

Maximum allowable wheel load determined in accordance with CMAA Specification No. 74 is 6500 pounds. Weight of one 54" wheelbase end truck is 225 pounds and of one 72" wheelbase truck is 300 lbs.

MATERIAL TO BE PURCHASED LOCALLY TO COMPLETE A CRANE BRIDGE

1. Bridge Beam. Obtain one length of American Standard I-Beam Section at the size recommended (see chart on page 1) or American Standard Wide Flange Beam Section at the size recommended (see chart on page 2) for the required capacity and span of bridge. The beam selected should be reviewed by a structural engineer for the application. The beam that you order must be a minimum length of the span plus 9-1/4". The beam selected must be straight with flanges parallel to each other and flanges at 90 degrees to the web. See Figure 2. For long spans with the larger rated loads, a channel is also required. The channel must be a minimum length of the span minus 4'-0".

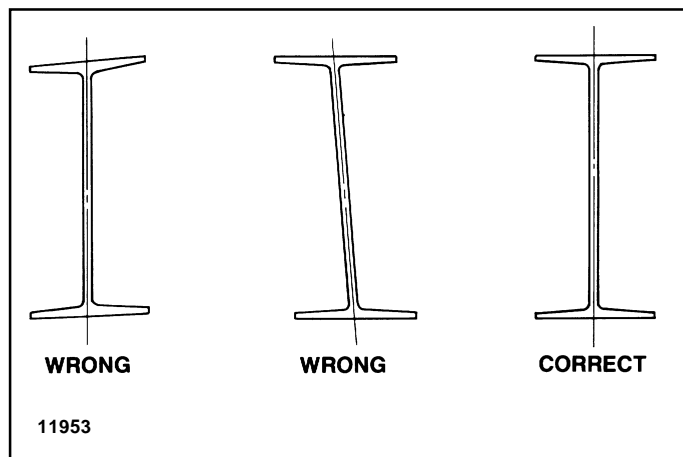

Figure 2. Correct Beam Selection.

2. Trolley Stops. Four (4) angles must be cut to size and installed at the ends of the bridge girder per Figure 7.

▲WARNING

Trolley stops (clip angles) must be installed on both ends of bridge beam (see Figure 7) to prevent hoist trolley from running off end of beam, which could result in injury to operator and others and damage to load and other property.

3. Cross Shaft. For hand geared and motor driven single drive cranes, cross shafts are also required. The cross shafts are to be 1" diameter AISI 1018 cold drawn steel with a standard mill tolerance of + .000", - .002". For spans thru 22'-0", only one length of cross shaft is required and the length required is the span minus 2'-2-1/2". For spans over 22'-0", two lengths of cross shaft are required. One length is to be 14'-9" and the other is to be the span minus 16'-11-5/8". Shaft lengths may be equalized if care is taken to clear supports.

NOTICE

A. All of the tables used in selection of structural steel beams have been produced by our engineering department using well established design guides for this type of crane bridge. IT IS IMPORTANT THAT ALL INSTRUCTIONS BE FOLLOWED AND THAT RECOMMENDED COMPONENT APPLICATION LIMITS NOT BE EXCEEDED.

B. Assembly of beam and channel requires welding. IT IS EXTREMELY IMPORTANT TO THE SAFETY OF THIS BRIDGE THAT THIS WELDING BE DONE BY A COMPETENT WELL TRAINED WELDER. It is our strong recommendation that the welder used in this construction be qualified as prescribed by the American Welding Society (AWS) Specification for Welding Industrial and Mill Cranes D14.1 - latest issue.

FABRICATION OF GIRDER FOR BRIDGE BEAM WITH CAPPING CHANNEL

Refer to Figure 3. Place channel on supports as shown in Step I. The I-beam is sighted for camber and placed with camber in direction shown in Step II. Weld one end of channel to the I-beam. Clamp, with "C" clamps, the channel to the I-beam flange - provide sufficient "C" clamps so as to hold channel in contact with the I-beam. Weld in accordance with the weld information given, starting at one end, staggering weld from side-to-side, proceeding to the opposite end without interruption. It is important to stagger weld from side-to-side in order to retain beam straightness. After welding, draw a taut string from end to end of beam as shown. Beam should either be parallel to string or have some camber. Camber should not exceed 1/800 of span.

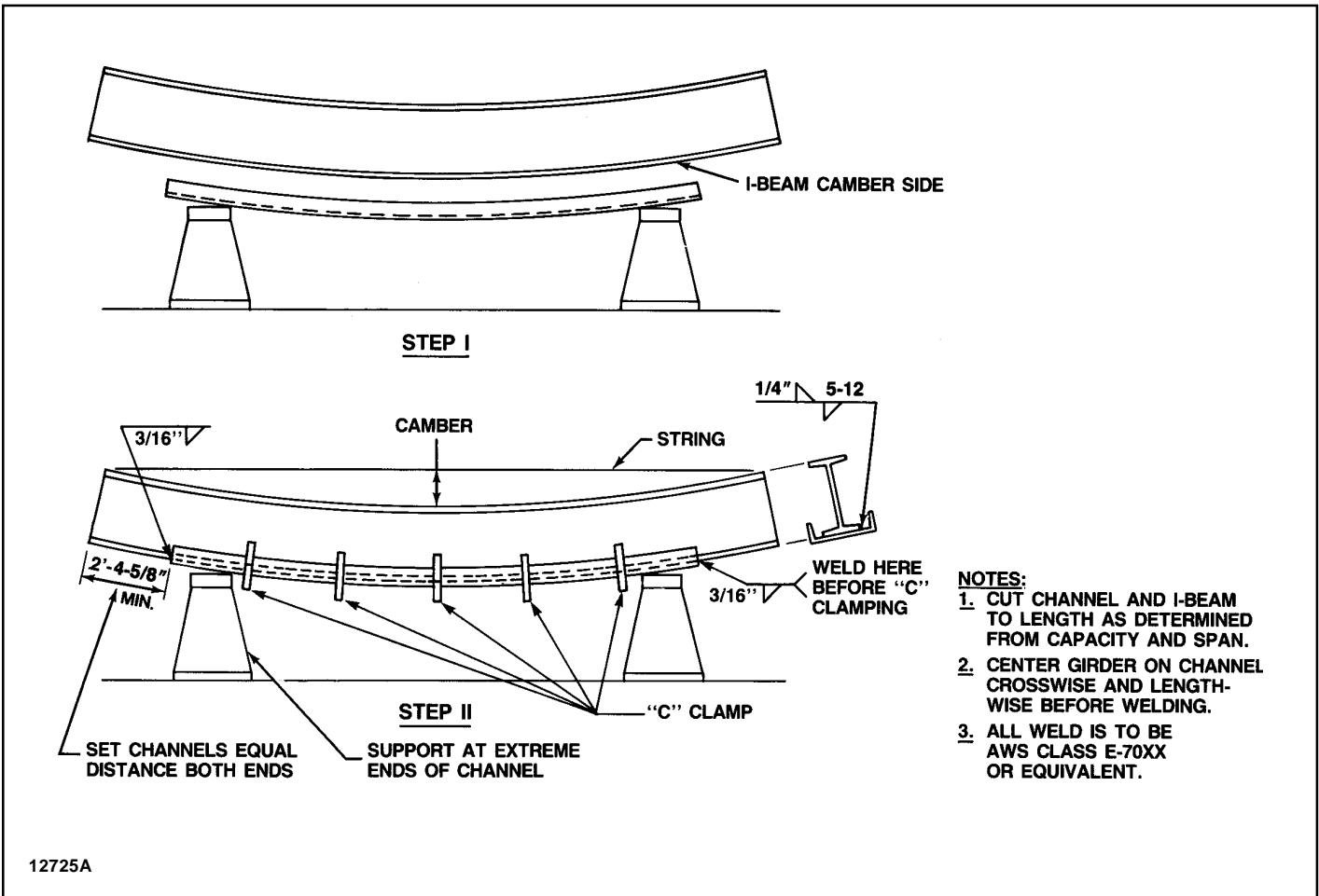

Figure 3.

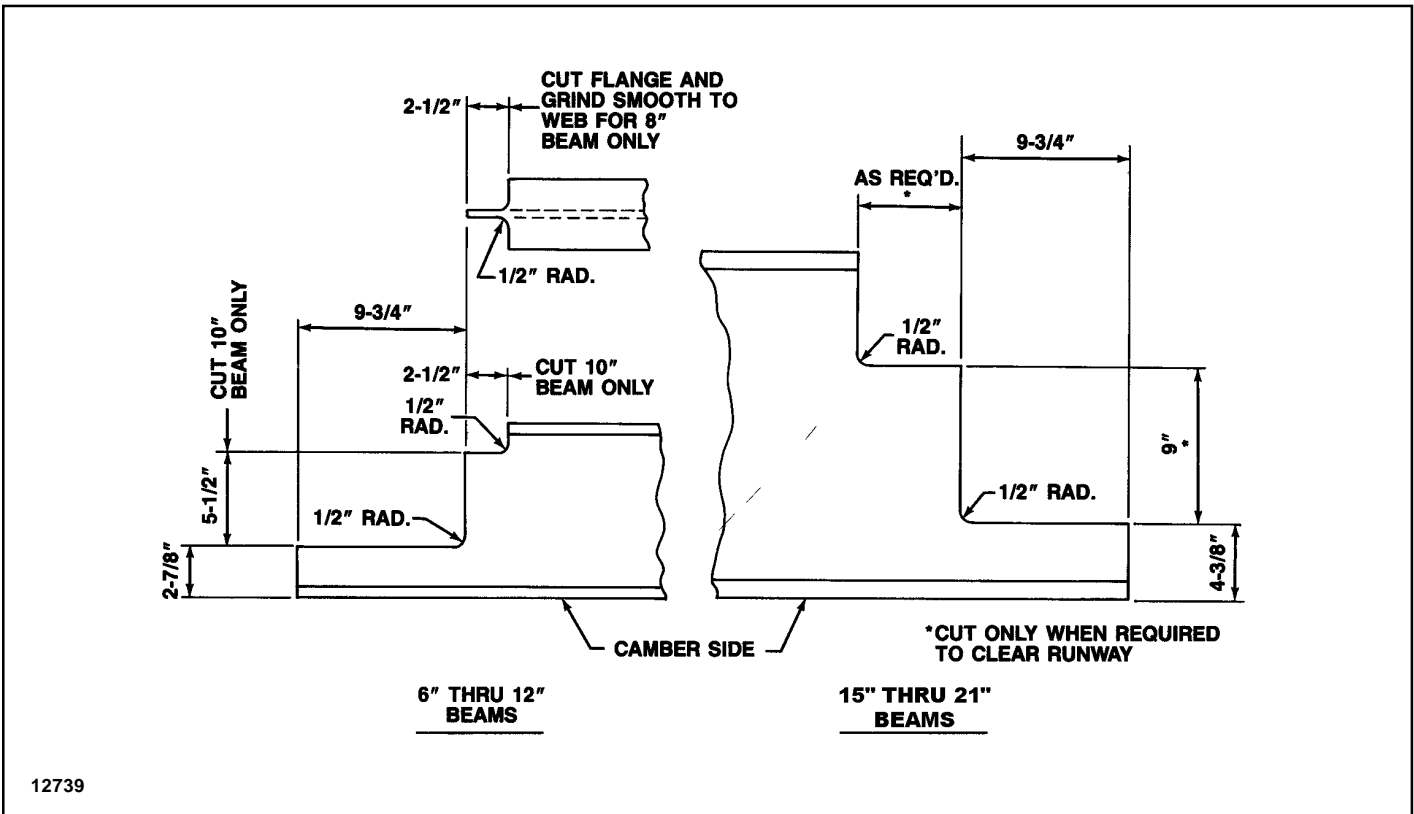

Figure 4. Cutting Diagram.

NOTCHING OF BRIDGE BEAM TO FIT END TRUCKS

Note the bridge beam end connections shown in Figure 6. If adequate headroom is available above the truck, there is an optional end connection shown for push cranes for 6", 7" and 8" beams only that does not require notching of the beam.

If notching is required, set beam on supports as shown in Step 1 of Figure 3. If a channel has been welded to the beam, the beam is already in the proper position. Cut notches in both ends of the beam using cutting diagram of Figure 4 and the proper dimensions for the required beam size. Notch is made by cutting torch with the burned area smoothed by grinding.

INSTRUCTIONS FOR ASSEMBLING PUSH BRIDGE WITH COPED GIRDER

1. Turn beam over on supports with camber side up. When setting up beam on supports, make certain that the bottom flange is level as shown in Figure 5. The larger wheel flange goes inside the span.
2. Position long angles from kit as shown in Figure 6 and securely clamp into place.
3. Set up, square, block and securely clamp trucks into position as shown in Figure 6. Make certain trucks are level with each other and are level with bottom flange of bridge beam as shown in Figure 5 (it is possible that top flange of beam may not be level even though bottom flange is). When leveling trucks, use either the centerline of the wheel axles or the diameter of the wheels. **DO NOT LEVEL FROM TRUCK STRUCTURE.** Correct operation of hoist-trolley unit requires that the bottom flange be level.
4. For beams over 7" deep; when leveling the bottom flange of the

bridge beam, clamp the short angle in position shown in Figure 6 to secure the position of the beam. Discard short angles for 6" and 7" beams.

5. Square end truck to end of bridge beam at one end of beam. Make sure trucks are parallel by measuring outside of wheel flanges across span at both ends of truck with end play for all wheels taken up in one direction.
6. Check center to center of trucks. This may be done by measuring from the inside edge of the truck at one end of the bridge to the outside corresponding edge of the truck at the other end of the bridge. This should equal the span length.
7. When all dimensions are confirmed, bottom flange of bridge beam is parallel to wheels of truck and truck is securely clamped to bridge beam, weld the two long angles at each end of the bridge beam to the web as shown in Figure 6.
8. Drill 4 holes 41/64" diameter thru truck flanges using holes in angles as a template at both ends of bridge.
9. For beams over 7" deep, weld the short angle at each end of the bridge beam to the web as shown in Figure 6.
10. Drill 2 holes 41/64" diameter thru bridge beam web using holes in angle as a template in locations shown in Figure 6, at both ends of bridge.
11. Assemble long angles to truck flange using eight (four at each end of bridge) 5/8" diameter bolts furnished with kit. Put one flat washer under bolt head and one under the self-locking nut.

Tighten all bolts and nuts using the turn-of-nut method. This is done by alternately bringing bolts and nuts to a "snug-tight" condition to ensure that mating surfaces are brought into full contact with each other. Then, make a final 1/2 turn on all bolts and nuts.

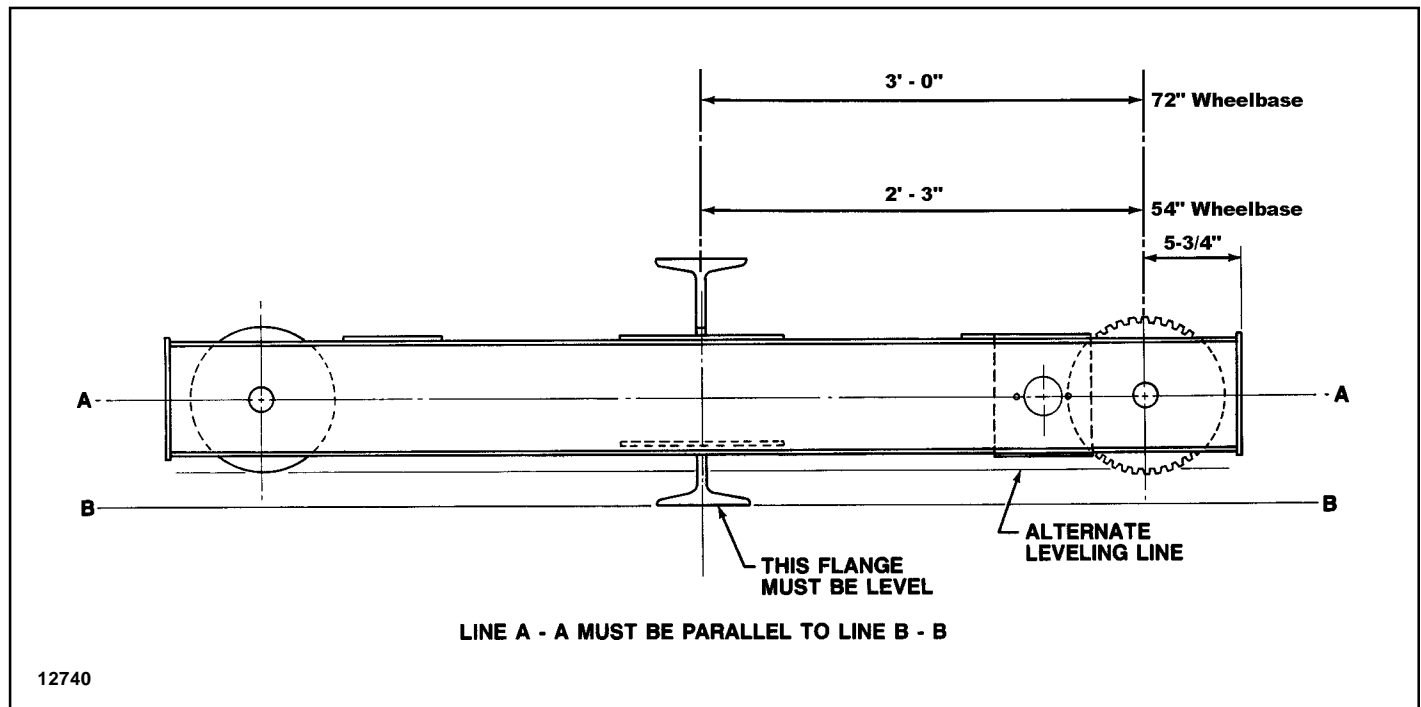
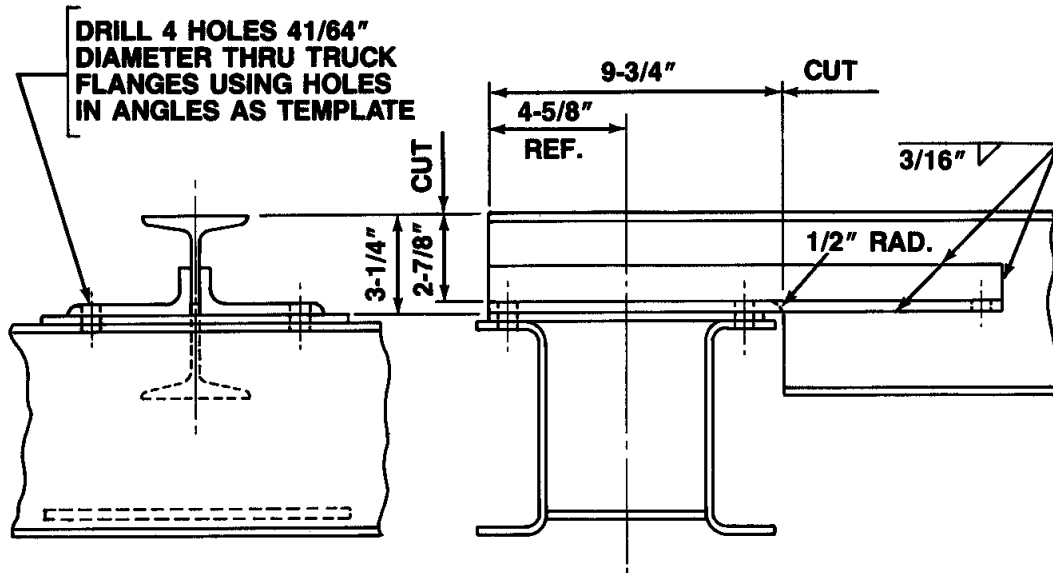

Figure 5. Method of Setting End Truck to Girder.

6" AND 7" BEAMS



12741A

8" BEAMS

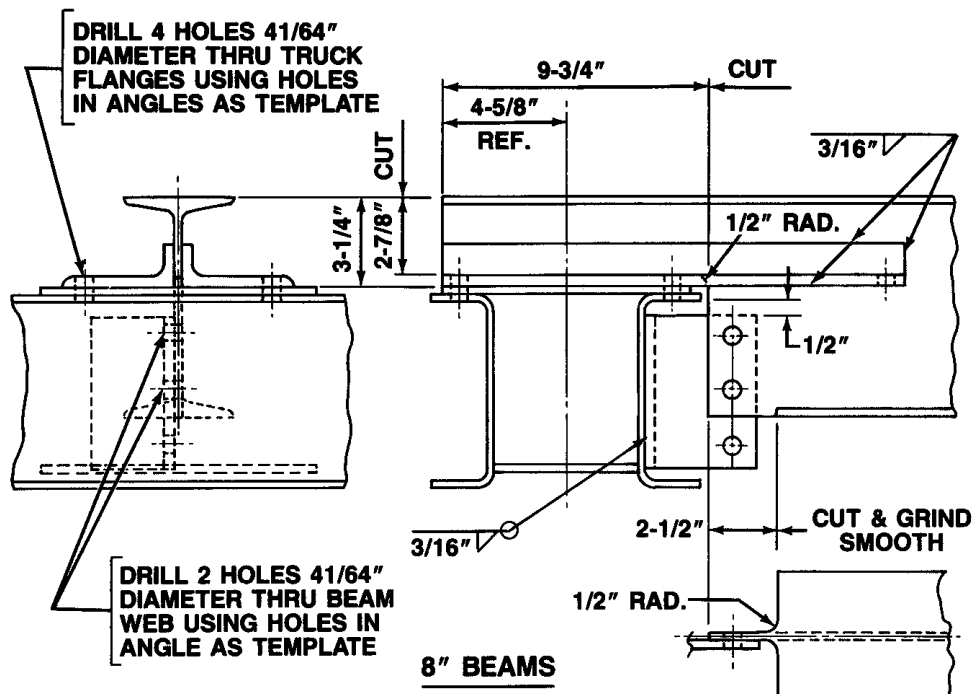

12741B

10" BEAMS

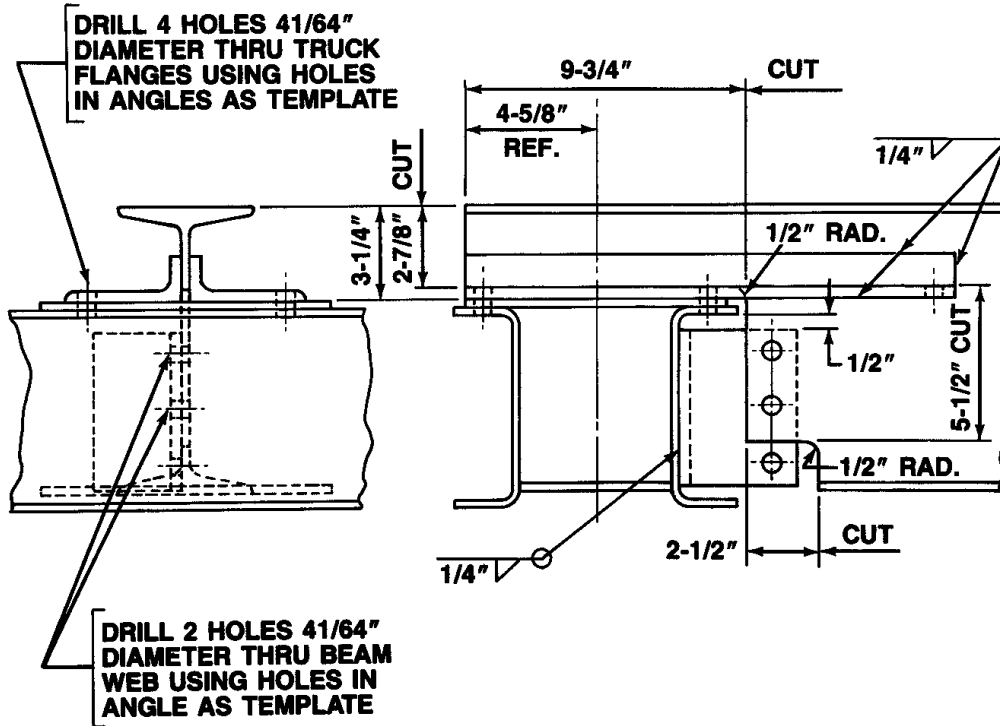

12741C

12" BEAMS

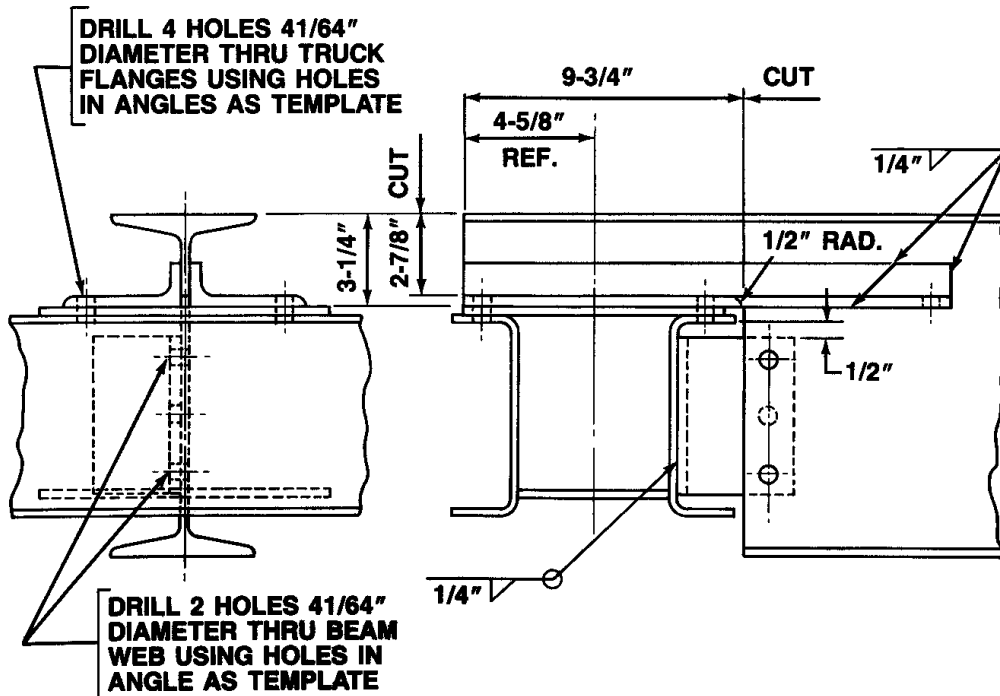

12741D

15", 18" & 20" BEAMS

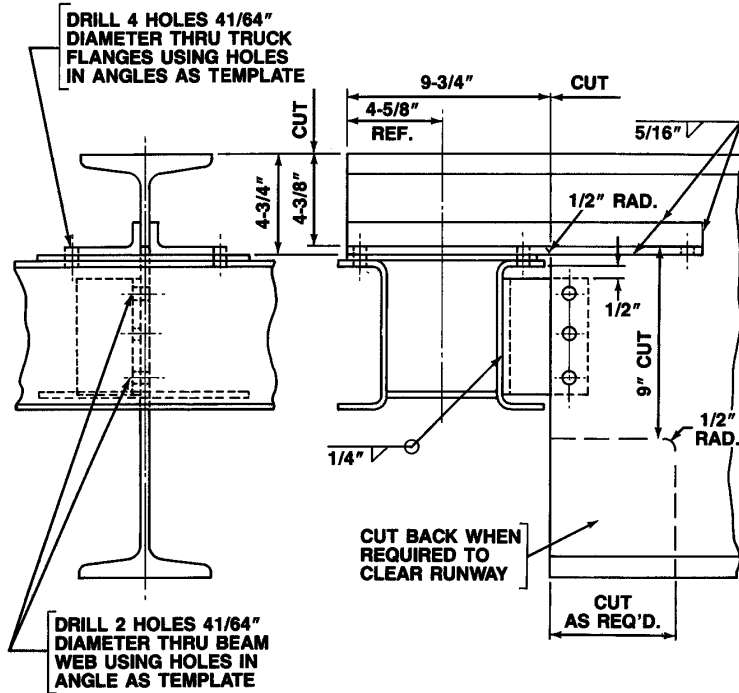

12741E

OPTIONAL END CONNECTION
FOR 6", 7" & 8" BEAMS

(OPTIONAL END CONNECTION FOR PUSH CRANES ONLY. DO NOT USE FOR GEARED MODELS)

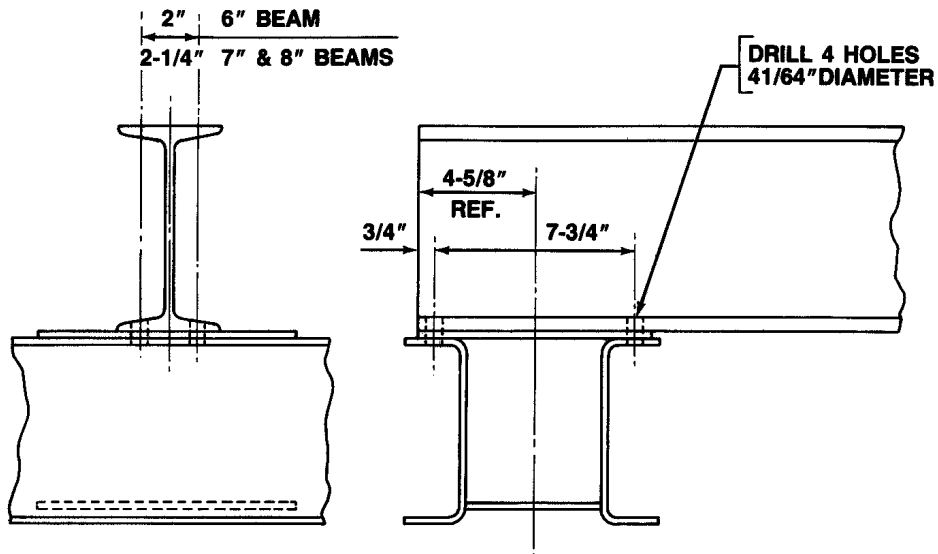

12741F

Figure 6. Bridge Beam End Connections.
All weld is to be AWS Class E-70XX or equivalent.

UNCOPEL GIRDER END CONNECTION

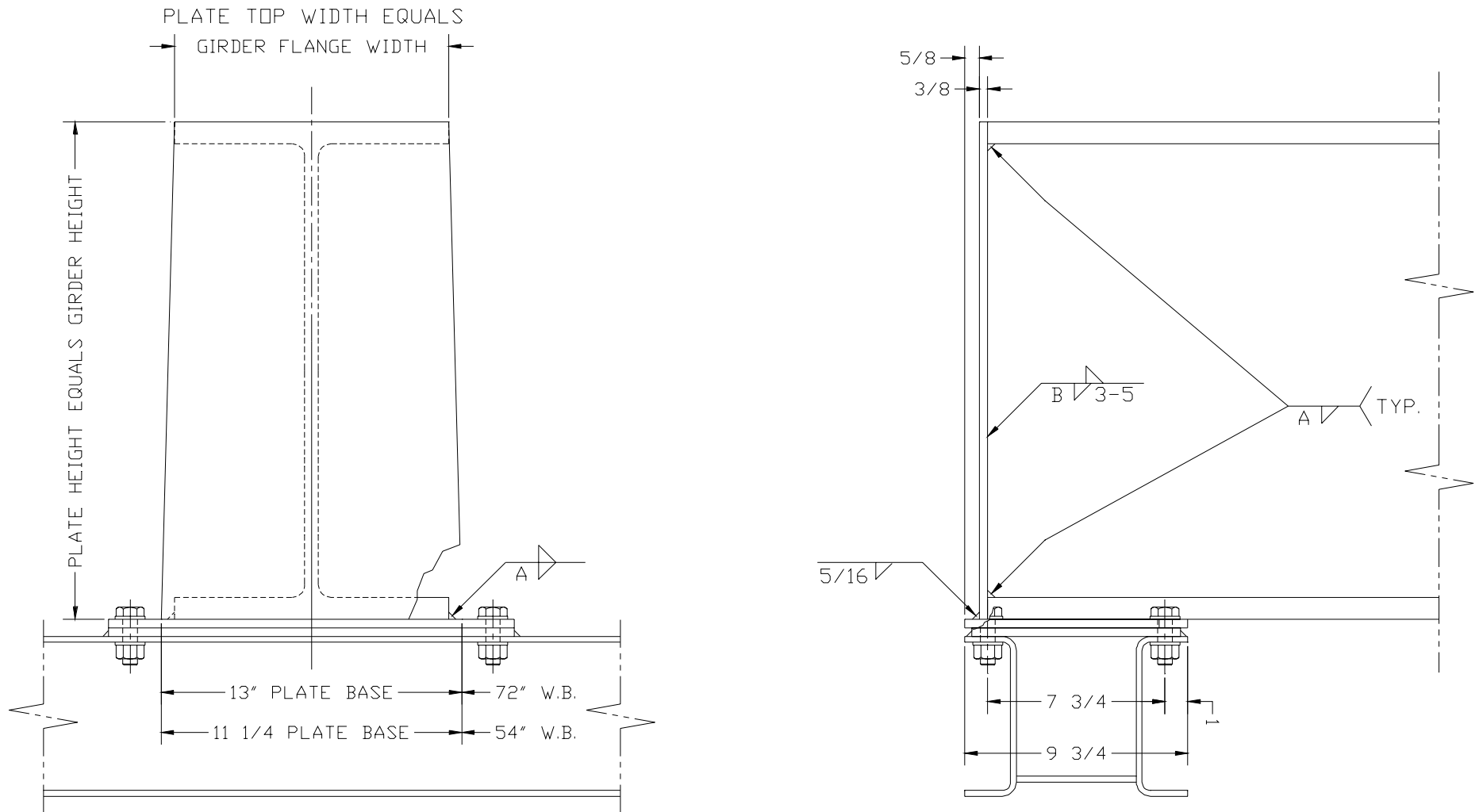

Weld Size 'A' - Girder Flange Thickness Minus 1/16" But not greater than 5/16"
 Weld Size 'B' - Girder Web Thickness Minus 1/16" But not greater than 5/16"

Figure 6a. Bridge Beam End Connections.
 All weld is to be AWS Class E-70XX or equivalent.

BRIDGE BEAM LENGTH = SPAN + (9-1/4")

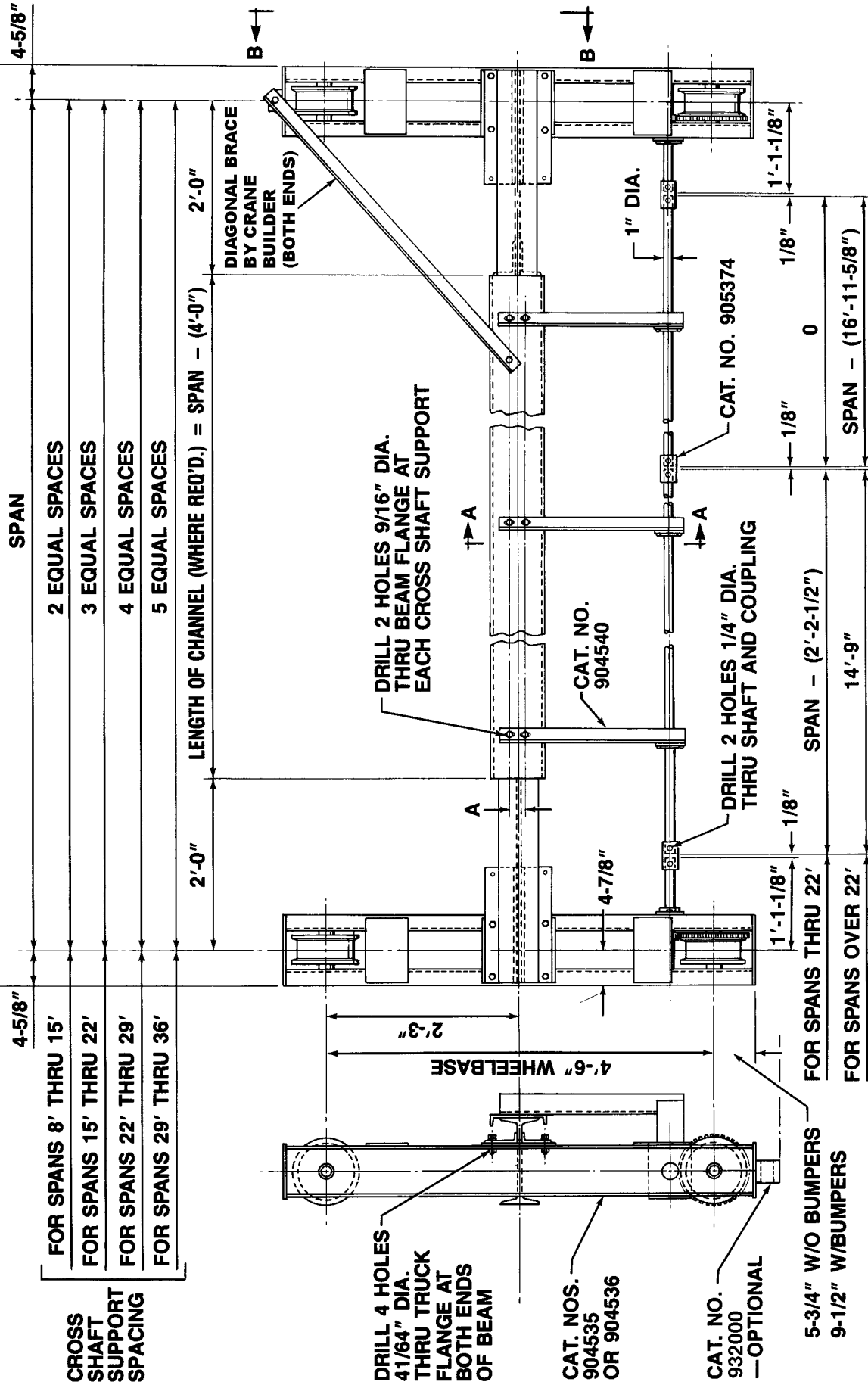

PLAN VIEW

12742A

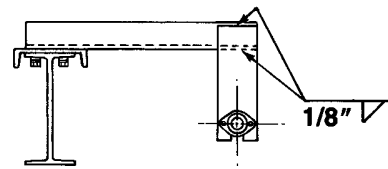
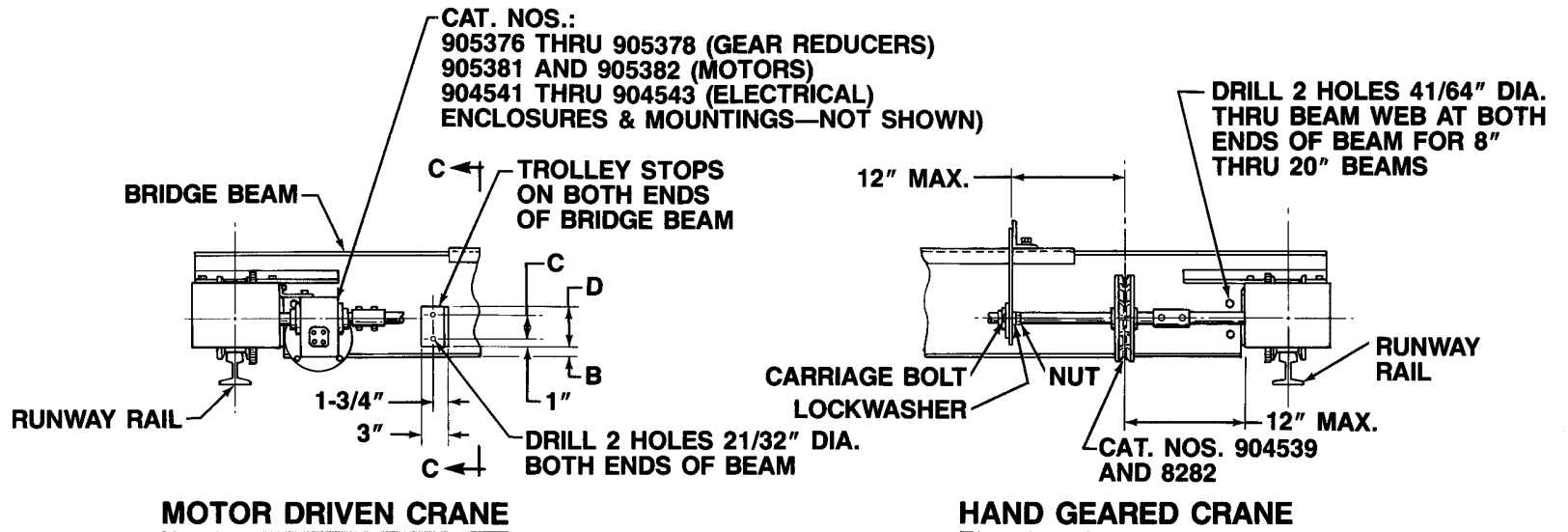

SECTION A-A

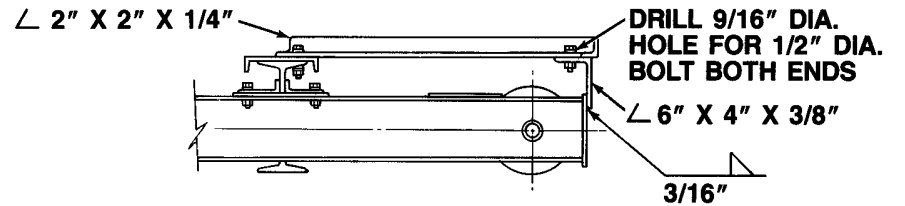

SECTION B-B

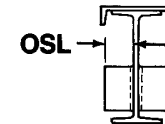

SECTION C-C

*Trolley frame or bumpers should contact trolley stops. If not, cut out standing leg (OSL) back to dimension shown.

Size of Bridge Beam	A	Trolley Stop Angle Size* (4 Req'd.)	B	C	D	OSL
6" x 12.5	2"	3 x 3 x 3/8	1"	2"	4"	1-1/2"
7" x 15.3	2-1/4"	3 x 3 x 3/8	1"	3"	5"	1-5/8"
8" x 18.4	2-1/4"	3 x 3 x 3/8	1"	3"	5"	1-3/4"
10" x 25.4	2-3/4"	3-1/2 x 3 x 3/8	1-1/4"	3"	5"	2-1/8"
12" x 31.8	3"	3-1/2 x 3 x 3/8	1-1/4"	3"	5"	2-1/4"
15" x 42.9	3-1/2"	4 x 3 x 3/8	1-1/2"	3"	5"	2-1/2"
18" x 54.7	3-1/2"	4 x 3 x 3/8	1-1/2"	3"	5"	2-3/4"
20" x 66	3-1/2"	5 x 3 x 3/8	1-3/4"	3"	5"	2-3/4"

Figure 7.

TYPICAL REQUIRED UNCOPED GIRDER END BRACING PROVIDED AND INSTALLED BY CRANE BUILDER

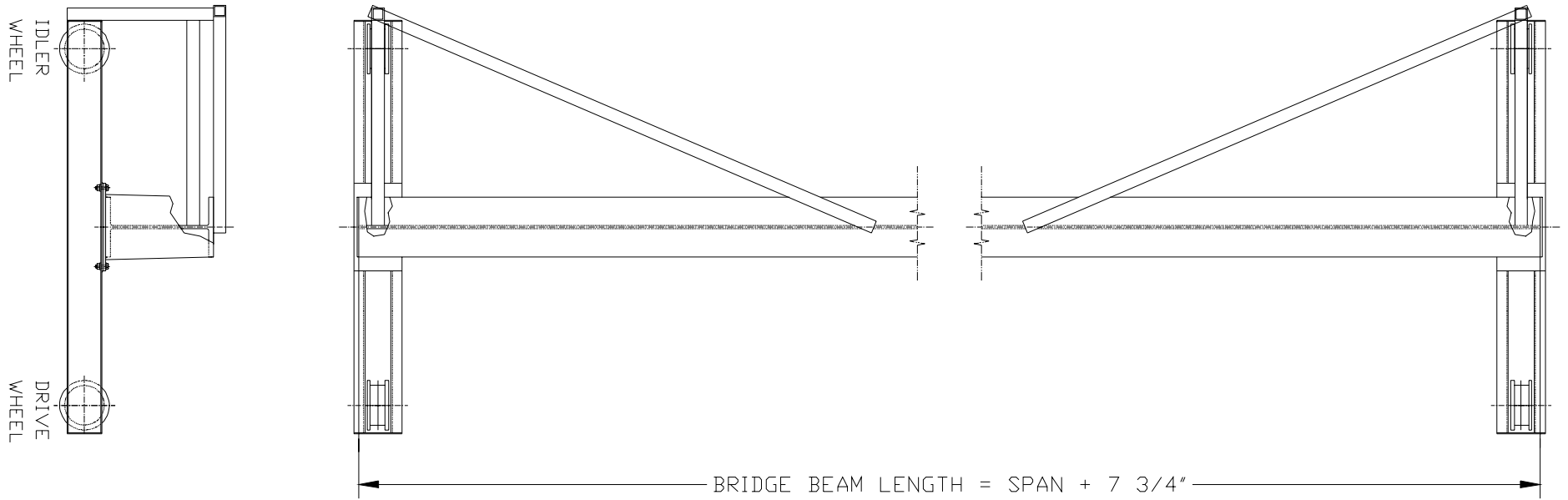

Figure 7a.

CAUTION

Do not substitute standard bolts and nuts for the special truck connecting bolts and nuts furnished with kit. Only high-strength bolts (S.A.E., grade 5) and elastic collared self-locking nuts, as furnished, are acceptable for attaching truck frames to bridge beam. High strength bolts are identified on the top of the head by three radial lines, equally spaced at 120 degrees. Self-locking nuts must have two threads, minimum extending thru nut. If necessary, discard flat washer to get two threads.

12. For bridge beams over 7", bolt short angle welded at truck to bridge beam web with four (two at each end of bridge) 5/8" diameter bolts furnished with kit. Tighten using turn-of-nut method.
13. Optional End Connection for 6", 7" and 8" Beams Only.
 - a. Drill 4 holes 41/64" diameter thru bridge beam lower flange and truck flanges in locations shown in Figure 6 at both ends of bridge.
 - b. Assemble beam to truck using eight (four at each end of bridge) 5/8" diameter bolts furnished with kit. Put beveled washer under bolt head and against I-beam flange. Use self-locking nut (no flat washer) and tighten using turn-of-nut method.
14. Mount trolley stops to I-beam web in position shown in Figure 7. Stops may be welded or bolted in place. If bolted, drill holes using 21/32" diameter drill as indicated in Figure 7. 5/8" diameter bolts with self-locking nuts should be used to secure stops.
15. If it is desired to increase the rigidity of the bridge, four angles (one to each corner) may be added in the position shown as "Optional" (at 45° to the bridge I-beam) in Figure 7. On a motor driven crane it may be necessary to move the electrical enclosure for clearance reasons.

INSTRUCTIONS FOR ASSEMBLING PUSH BRIDGE WITH UNCOPIED GIRDER

1. Turn Beam over on supports with camber side up. When setting up beam on supports, make certain that the bottom flange is level as shown in Figure 5. The larger wheel flange goes inside the span.
 2. Position girder mounting plates on top of each truck center plate and clamp securely. Drill 4 holes 41/64" diameter through truck center plate and flanges of truck channels using holes in girder mounting plate as template.
 3. Assemble girder mounting plate to top plate of each truck using eight (four at each end of bridge) 5/8" diameter high strength grade 5 bolts furnished with end connection kit. Put one flat washer under bolt head and one under the self locking nut.
- Tighten all bolts and nuts using the turn-of-nut method. This is done by alternately bringing bolts and nuts to a "snug-tight" condition to ensure that mating surfaces are brought into full contact with each other. Then, make a final ½ turn on all bolts and nuts.
4. Set up, square, block and securely clamp trucks into position as shown in Figure 6. Make certain trucks are level with each other and are level with bottom flange of bridge beam as shown in Figure 5 (it is possible that top flange of beam may not be level even though bottom flange is). When leveling trucks use either the centerline of the wheel axles or the diameter of the wheels.

DO NOT LEVEL FROM TRUCK STRUCTURE. Correct operation of hoist-trolley requires that the bottom flange be level.

5. Square end truck to end of bridge beam at one end of beam. Make sure trucks are parallel by measuring outside of wheel flanges across span at both ends of truck with end play for all wheels taken up in one direction.
6. Check center to center of trucks. This may be done by measuring from the inside edge of the truck at one end of the bridge to the outside corresponding edge of the truck at the other end of the bridge. This should equal the span length.
7. When all dimensions are confirmed, bottom flange of bridge beam is parallel to wheels of truck and truck is securely clamped to bridge beam, weld the girder bottom flange to the girder mounting plate as shown in Figure 6.
8. Cut 3/8" girder end cap plate and weld to end of girder and girder mounting plate as shown in Figure 6.
9. To provide rigidity to the bridge, four braces (one to each corner and one to girder web parallel to truck) may be added in the position shown in Figure 7a. On a motor driven crane it may be necessary to move the electrical enclosure for clearance.
10. Mount trolley stops to beam girder web in position shown in Figure 7. Stops may be welded or bolted in place. If bolted, drill holes using 21/32" diameter drill as indicated in Figure 7. 5/8" diameter bolts with self-locking nuts should be used to secure stops. Stop material by customer.

INSTRUCTIONS FOR ASSEMBLING HAND GEARED CRANE BRIDGE

1. Follow instructions for assembling the appropriate push crane bridge.
2. Locate and drill holes for cross shaft supports.
3. Bolt the cross shaft support angles to the bridge beam. The flat washer goes under the bolt head and the beveled washer goes between the beam flange and the lockwasher and nut.
4. Attach a flange bearing to each cross shaft support plate with two carriage bolts, lockwashers and hex nuts. The carriage bolt head locks in the bearing (see Figure 13).
5. Place the proper number of bearings and couplings on the cross shaft, set the unit in place and clamp the cross shaft support plates to the cross shaft support angles. The hand chain wheel and chain guide must also be placed on the cross shaft before placing. They may be positioned anywhere across the span, but must be within 12" of a cross shaft support or truck.
6. Check horizontal alignment of the cross shaft by using a taut line. Weld plates to angles when alignment is complete. Weld as shown in Section A-A of Figure 7.
7. Check the space between ends of cross shafts; it should be 1/8". Position the couplings and drill 1/4" diameter holes through the shaft and coupling using the holes in one side of the coupling as a guide. Shaft and coupling is secured by socket head cap screws with flat washers and self-locking hex nuts (see Figure 14). Tighten set screws in flange bearings.
8. Set position of hand chain wheel and chain guide (within 12" of cross shaft bracket or truck) with set screw on hand chain wheel. Determine length of operating hand chain (chain should hang about 2 feet 6 inches above floor), cut chain and make it endless by installing and closing open link furnished with chain.

INSTRUCTIONS FOR ASSEMBLING MOTOR DRIVEN SINGLE DRIVE CRANE BRIDGE

INSTRUCTIONS FOR ASSEMBLING MOTOR DRIVEN DUAL DRIVE CRANE BRIDGE

1. Follow instructions for assembling push crane bridge.
2. Locate and drill holes for cross shaft supports.
3. Bolt the cross shaft support angles to the bridge beam. The flat washer goes under the bolt head and the beveled washer goes between the beam flange and the lockwasher and nut.
4. Bolt the motor to the gear reducer with four hex head bolts and lockwashers and bolt the support plate to the gear reducer with two hex socket head cap screws and lockwashers. The drive may go on either end of the bridge. Optional motor-gear reducer locations are shown in Figure 8. The vent (Ref. No. 15 in Figure 16) must be placed in the highest location.
5. Place key in truck drive shaft, slide gear reducer into place over shaft and bolt support plate to side of truck with two hex socket head cap screws and lockwashers. Maximum allowable torque is 10 pound feet. Tighten six set screws in gear reducer hollow shaft (Ref. No. 18 in Figure 16).
6. Using the 9/32" diameter hole in the support plate as a guide, drill a 5/16" diameter hole through the support plate and truck side and drive the groove pin, furnished, into the hole (Ref. No. 4 in Figure 16).
7. Attach a flange bearing to each cross shaft support plate with two carriage bolts, lockwashers and hex nuts. The carriage bolt head locks in the bearing (see Figure 13).
8. Place the proper number of bearings and couplings on the cross shaft, set the unit in place and clamp the cross shaft support plates to the cross shaft support angles.
9. Check horizontal alignment of the cross shaft by using a taut line. Weld plates to angles when alignment is complete. Weld as shown in Section A-A of Figure 7.
10. Check the space between cross shafts; it should be 1/8". Position the couplings and drill 1/4" diameter holes through the shaft and coupling using the holes in one side of the coupling as a guide. Shaft and coupling is secured by socket head cap screws with flat washers and self-locking hex nuts (see Figure 14). Tighten set screws in flange bearings.
11. The electrical enclosure is shown mounted on the inside of the truck over the gear reducer in Figure 17. The connecting bracket may be mounted in any of 3 vertical locations on the enclosure bracket when oriented as shown. It may also be rotated 180° (out standing leg at top) giving 3 additional positions. The enclosure bracket may also be adjusted horizontally on the enclosure. The connecting bracket may be welded to a truck or to the girder. If the bracket rests on the supporting member, a 1" minimum overlap is required. Weld as shown in Figure 9. If the bracket is to be supported by weld at the toe only, a stiffener plate must be furnished by the crane fabricator. Weld as shown in the alternate view in Figure 9.
12. Mount fused disconnect switch in any safe, convenient location.

1. Follow instructions for assembling push crane bridge.
2. Bolt the motors to the gear reducers with four hex head bolts and lockwashers orienting the motor junction boxes appropriately after selecting the motor-gear reducer location from the options illustrated in Figure 8. Bolt the support plate to the gear reducer with two hex socket head cap screws and lockwashers. The highest oil plug in the gear reducer must be removed and the vent be installed. The hardware, vent and support plate are provided with the gear reducer.
3. Place the key in the truck drive shaft and slide the gear reducer hollow shaft onto the drive shaft over the key. Bolt the support plate to the side of the truck with two hex socket head cap screws and lockwashers. Maximum allowable bolt torque is 10 pound feet.
4. Repeat instruction 3 at the opposite end truck.
5. The electrical enclosure is shown mounted on the inside of the truck over the gear reducer in Figure 17. The connecting bracket may be mounted in any of 3 vertical locations on the enclosure bracket when oriented as shown. It may also be rotated 180° (outstanding leg at top) giving 3 additional positions. The enclosure bracket may also be adjusted horizontally on the enclosure. The connecting bracket may be welded to a truck or to the girder. If the bracket rests on the supporting member, a 1" minimum overlap is required. Weld as shown in Figure 9. If the bracket is to be supported by weld at the toe only, a stiffener plate must be furnished by the crane bridge fabricator. Weld as shown in the alternate view in Figure 9.
6. Mount fused disconnect switch in any safe convenient location.

PAINTING

After assembly, all plain steel surfaces should be painted. Thoroughly clean surfaces of oily spots and rust using a suitable solvent. It is recommended that a national brand zinc-chromate primer be applied before a finish coat of high gloss enamel especially suited for steel surfaces.

MARKING

Codes require that the capacity of the bridge be shown on both sides of crane bridge, legible from the floor. Normal practice for marking is to use capacity in tons, for example: 1 TON, 2 TON, etc. Stencil forms are readily available that may be used with brush-on or pressurized spray-can paint.

NOTICE

The crane builder and user are responsible for marking crane and also to check for compliance with all local, state and national codes.

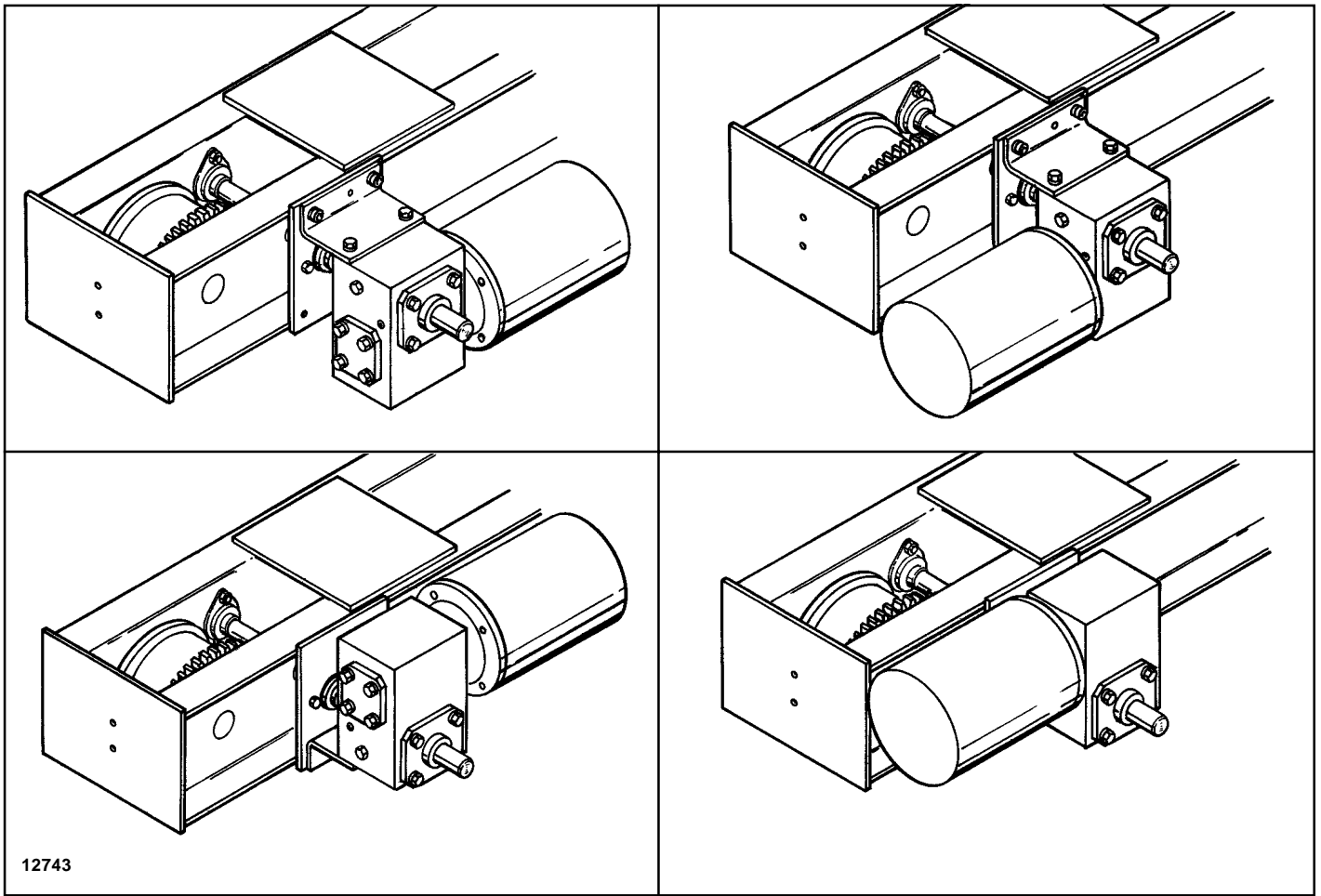

Figure 8.

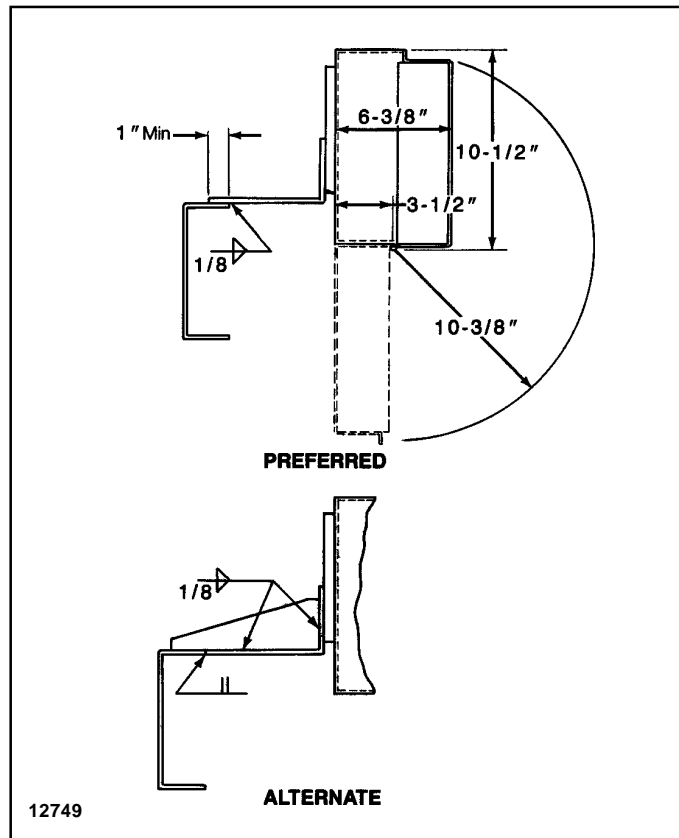

Figure 9.

INSTALLATION OF CRANE BRIDGE

WARNING

Be certain that electrical power supply to runway current conductors (if used) is “off” and locked in the open position.

1. Assure lifting equipment is adequate to lift total weight of crane.
2. Carefully set crane bridge onto runway. Check to see that runway stops have been installed and that they engage the ends of the end trucks simultaneously.

WARNING

Runway stops must be installed to prevent crane bridge from running off the end of the runway rail resulting in injury to the operator and others and damages to load and other property.

3. After crane is placed on runway rail, check wheel flange clearances to rail. Clearance between side of rail head and inside flange of wheel will vary from 1-3/8" for an ASCE 20# runway rail (minimum recommended rail size) to 3/8" for an ASCE 60# runway rail (maximum recommended rail size).
4. When applicable follow National, State and Local electrical codes when providing electrical service to crane bridge. Make electrical connections according to the wiring diagrams furnished with the crane bridge.

CAUTION

Power supply must be same voltage, phase and frequency as specified on crane bridge motor nameplate.

CAUTION

Do not attempt to operate crane bridge before completing tests and adjustments.

WARNING

This equipment must be effectively grounded according to the National Electrical Code, or other applicable codes. Certain environments may prevent proper grounding by this means and in this case a separate grounding conductor should be provided.

FUSE AND MAINLINE DISCONNECT PANELS

Mainline disconnect panels and fused bridge control panels are provided as options to assist users in complying with OSHA and NEC codes. When ordered with crane bridge kits, they will be completely installed inside of electrical enclosures.

Electrical service shall be connected to crane equipped with fuse panels and mainline disconnect panels as shown in wiring diagram.

OPERATING PRECAUTIONS

DO NOT load bridge beyond rated capacity.

DO NOT subject bridge to side loads. Always center trolley over load when hoisting.

DO NOT stand on and **DO NOT** cause or allow others to stand on or get under any load the bridge is supporting. **DO** keep clear, and make sure others keep clear, of any load the bridge is supporting.

DO NOT ram bridge into runway stops, another bridge, or any obstruction on runway rails. Improper and careless operation can result in a hazardous condition for operator and load.

ALWAYS be sure load is clear of obstruction before traversing load.

WARNING

These crane bridges are not designed nor intended to be used for support or transport of people or for transporting loads over people.

If crane bridge is mounted on an open-end runway rail, then runway stops must be installed to prevent crane bridge from running off the end of the runway rail resulting in injury to the operator and others and damages to load and other property.

Refer to hoist and trolley instruction manuals for safety warnings on hoists and trolleys.

Read and comply with ANSI B30.16 Overhead Hoists (Underhung) and ANSI B30.17 Overhead and Gantry Cranes (Top running bridge, Single Girder, Underhung Hoist), latest editions.

MAINTENANCE AND LUBRICATION

1. Inspect the bridge on a regular maintenance schedule. Check to make sure wheel axle bolts and all connections are tight. Check wheel tread surfaces for wear or damage. Check truck sides for any evidence of overload or damage. Replace any worn or damaged parts using only factory approved replacement parts.

2. Lubrication requirements:

a. Wheel bearings are permanently lubricated and require no additional lubricant.

b. Drive wheel gears are to be lubricated with an open type gear grease which is heavy, plastic, extreme pressure and tacky; such as MOBILTAC 275 or equal.

c. The hollow shaft worm gear reducer lubricant should be changed every year or 2000 hours of service for moderate usage. The lubricant should be changed more frequently if the service is more severe. Use one pint of AGMA lubricant number 7, compounded, if the ambient temperature is 15° to 60° F or AGMA lubricant number 8, compounded, if the ambient temperature is 50° to 125° F.

d. It is recommended that the areas of the cross shaft covered by gear reducers, bearings and couplings be coated with FEL-PRO C5-A, or equal, anti-seize lubricant.

Before crane operation the gear reducer(s) vent plug must be in the proper location in the gear reducer. The vent plug replaces the pipe plug in the highest location on the end of the gear reducer (see Figure 16).

3. If it becomes necessary to remove the cross shaft (Ref. No. 22 in Figure 12) from the geared truck, proceed as follows:

a. Remove gear reducer support plate screws (Ref. No. 3 in Figure 16).

b. Loosen hollow shaft screws (Ref. No. 18 in Figure 16) and slide gear reducer off cross shaft.

c. Loosen set screw in outer flange bearing (Ref. No. 19 in Figure 12) (mounted on truck channel).

d. Remove bolts (Ref. Nos. 18, 20 and 21 in Figure 12) holding inner flange bearing (mounted on vertical plate on truck).

e. Remove outer (nearest truck center) pinion retaining ring (Ref. No. 16 in Figure 12).

f. Slide cross shaft out of outer flange bearing (sliding toward center of crane) and remove retaining ring (Ref. No. 15 in Figure 12) by sliding ring over end of cross shaft.

g. Slide cross shaft out of pinion (Ref. No. 17 in Figure 12) and out of truck.

h. Clean and inspect all parts before reassembly. Replace all parts that are worn or damaged.

i. Reassemble following a reverse procedure of the disassembly steps listed above.

j. Lubricate drive wheel gears per paragraph 2.b. above.

4. After 3 months of initial crane operation, re-torque beam to truck bolts as called for in the assembly instructions and tighten all other bolts.

REPLACEMENT PARTS

The following parts list and illustrations cover standard model crane bridges. Typical units are used as the basis for the exploded parts illustrations; therefore, certain variations may occur from the parts information given. For this reason always give the catalog number, model number, motor horsepower, voltage, phase and frequency when ordering replacement parts. For motors, gearboxes, and electrical components, give complete nameplate data.

The factory recommends complete replacement of the motor or gearbox.

The numbers assigned to the parts of our various assemblies in our parts list are not the part numbers used in manufacturing the part. They are identification numbers, that when given with the catalog number, permit us to identify, select or manufacture and ship the correct part needed.

INDEX OF PARTS ILLUSTRATIONS

Title	Figure No.
Push Truck - Catalog Number 904535	11
Geared Truck - Catalog Number 904536	12
Cross Shaft Support - Catalog Number 904540	13
Coupling - Catalog Number 905374	14
Hand Chain Drive - Catalog Numbers 904539 and 8282	15
Gear Reducer (Catalog Numbers 905376 thru 905378) and Motor (Catalog Numbers 905381 and 905382)	16
Bolted Uncoped Girder Connection	17
Electrical Enclosure and Mounting - Catalog Numbers 904541 thru 904543	18

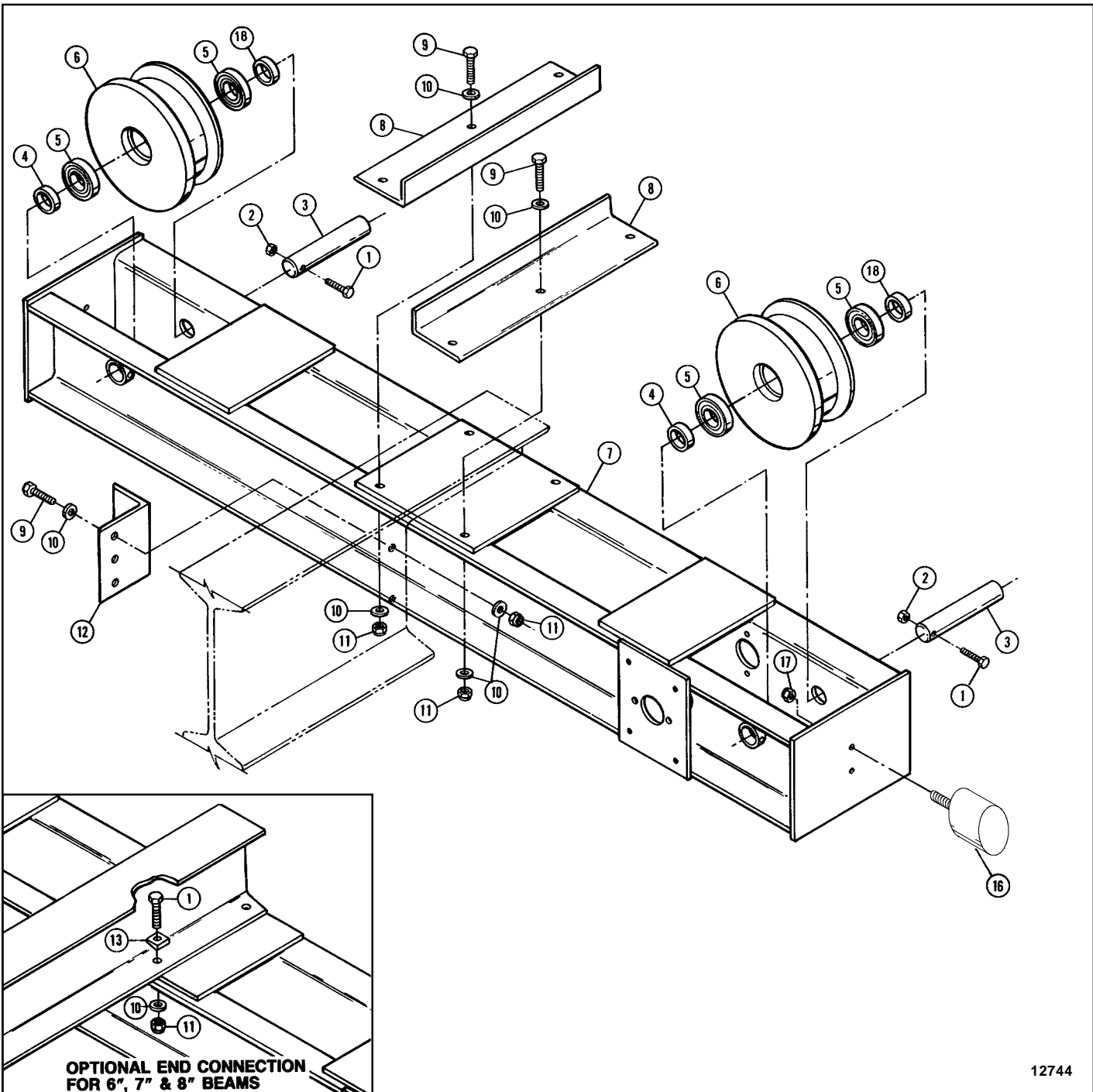

Figure 11. Push Truck. Catalog Number 904535. (Only 1 Truck Shown)
(Bumper is Optional. Catalog Number 932000.)

Figure 11. Push Truck. Catalog Number 904535. (Continued).
 (Bumper is Optional. Catalog Number 932000.)

Ref. No.	Part Number	Description	Qty. Req'd
1	BTK-2000	Hex Head Bolt - High Strength	2
2	BTK-2001	Self-Locking Nut	2
3	BTK-2002	Axle	2
4	BTK-2003	Bearing Retainer (Long)	2
5	BTK-2004	Bearing	4
6	BTK-2005	Wheel	2
7	BTK-2006	Truck Weldment	1
		Optional Coped Girder Connection Kit - Catalog Number 912101 Consists of Ref. Nos. 8 thru 12	
8	BTK-2007	Angle Connector	2
9	BTK-2008	Hex Head Bolt - High Strength	6
10	BTK-2009	Flat Washer	12
11	BTK-2010	Self-Locking Nut	6
12	BTK-2011	Angle Connector	1
		Optional Bumper - Catalog Number 904537 Consists of Ref. Nos. 14 thru 17	
14	BTK-2013	Hex Head Bolt	4
15	BTK-2014	Flat Washer	4
16	BTK-2015	Bumper	2
17	BTK-2016	Self-Locking Nut	4
18	BTK-2017	Bearing Retainer (Short)	2

NOTES

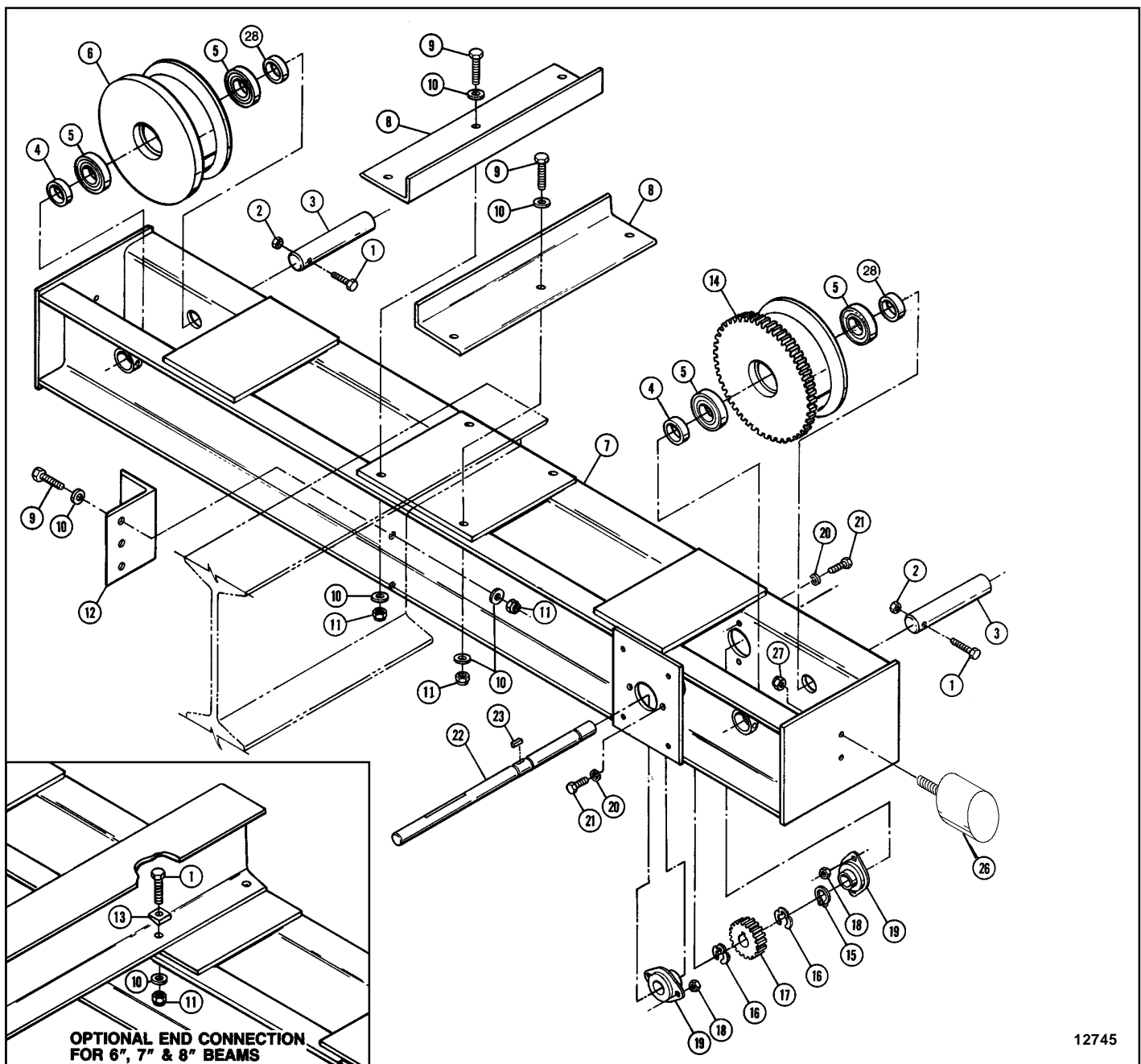

Figure 12. Geared Truck. Catalog Number 904536. (Only 1 Truck Shown)
 (Bumper is Optional. Catalog Number 932000.)

Ref. No.	Part Number	Description	Qty. Req'd
1	BTK-2100	Hex Head Bolt - High Strength	2
2	BTK-2101	Self-Locking Nut	2
3	BTK-2102	Axle	2
4	BTK-2103	Bearing Retainer (Long)	2
5	BTK-2104	Bearing	4
6	BTK-2105	Plain Wheel	1
7	BTK-2106	Truck Weldment	1
	BTK-2107	As Shown (Right Hand)	
	BTK-2107	Opposite Hand (Left Hand)	
		Optional Coped Girder Connection Kit - Catalog Number 912101	
		Consists of Ref. Nos. 8 thru 12	
8	BTK-2108	Angle Connector	2
9	BTK-2109	Hex Head Bolt - High Strength	6

Figure 12. Geared Truck. Catalog Number 904536. (Continued).
 (Bumper is Optional. Catalog Number 932000.)

Ref. No.	Part Number	Description	Qty. Req'd
10	BTK-2110	Flat Washer	12
11	BTK-2111	Self-Locking Nut	6
12	BTK-2112	Angle Connector	1
14	BTK-2114	Geared Wheel	1
15	BTK-2115	Retaining Ring	1
16	BTK-2116	Retaining Ring	2
17	BTK-2117	Pinion	1
18	BTK-2118	Hex Nut	4
19	BTK-2119	Flange Bearing	2
20	BTK-2120	Lockwasher	4
21	BTK-2121	Hex Head	4
22	BTK-2122	Cross Shaft	1
23	BTK-2123	Key	1
		Optional Bumper - Catalog Number 904537 Consists of Ref. Nos. 24 thru 27:	
24	BTK-2124	Hex Head Bolt	4
25	BTK-2125	Flat Washer	4
26	BTK-2126	Bumper	2
27	BTK-2127	Self-Locking Nut	4
28	BTK-2128	Bearing Retainer (Short)	2

NOTES

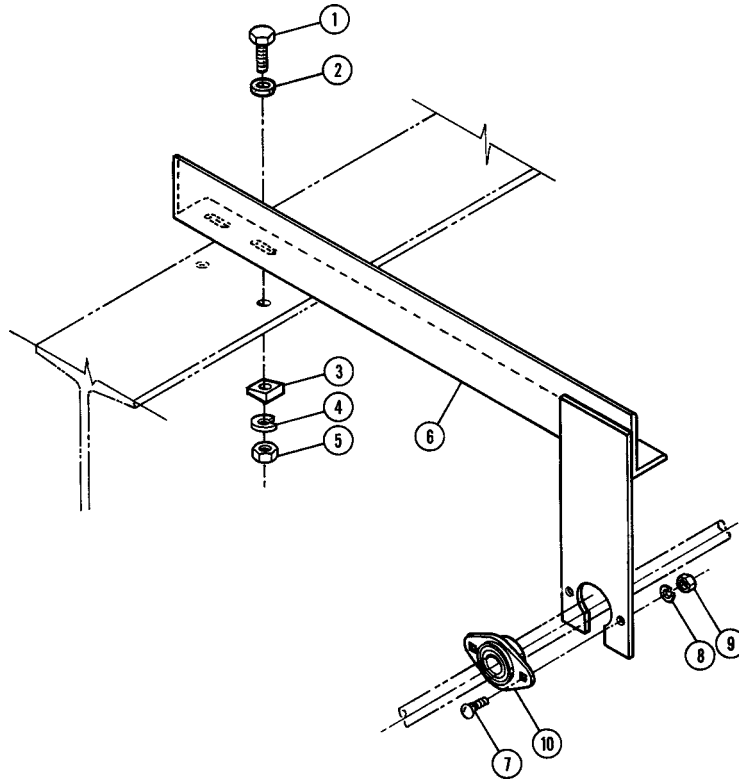

12746

Figure 13. Cross Shaft Support. Catalog Number 904540.

Ref. No.	Part Number	Description	Qty. Req'd
1	BTK-2200	Hex Head Bolt	2
2	BTK-2201	Flat Washer	2
3	BTK-2202	Beveled Washer	2
4	BTK-2203	Lockwasher	2
5	BTK-2204	Hex Nut	2
6	BTK-2205	Cross Shaft Support	1
7	BTK-2206	Carriage Bolt	2
8	BTK-2207	Lockwasher	2
9	BTK-2208	Hex Nut	2
10	BTK-2209	Flange Bearing	1

NOTES

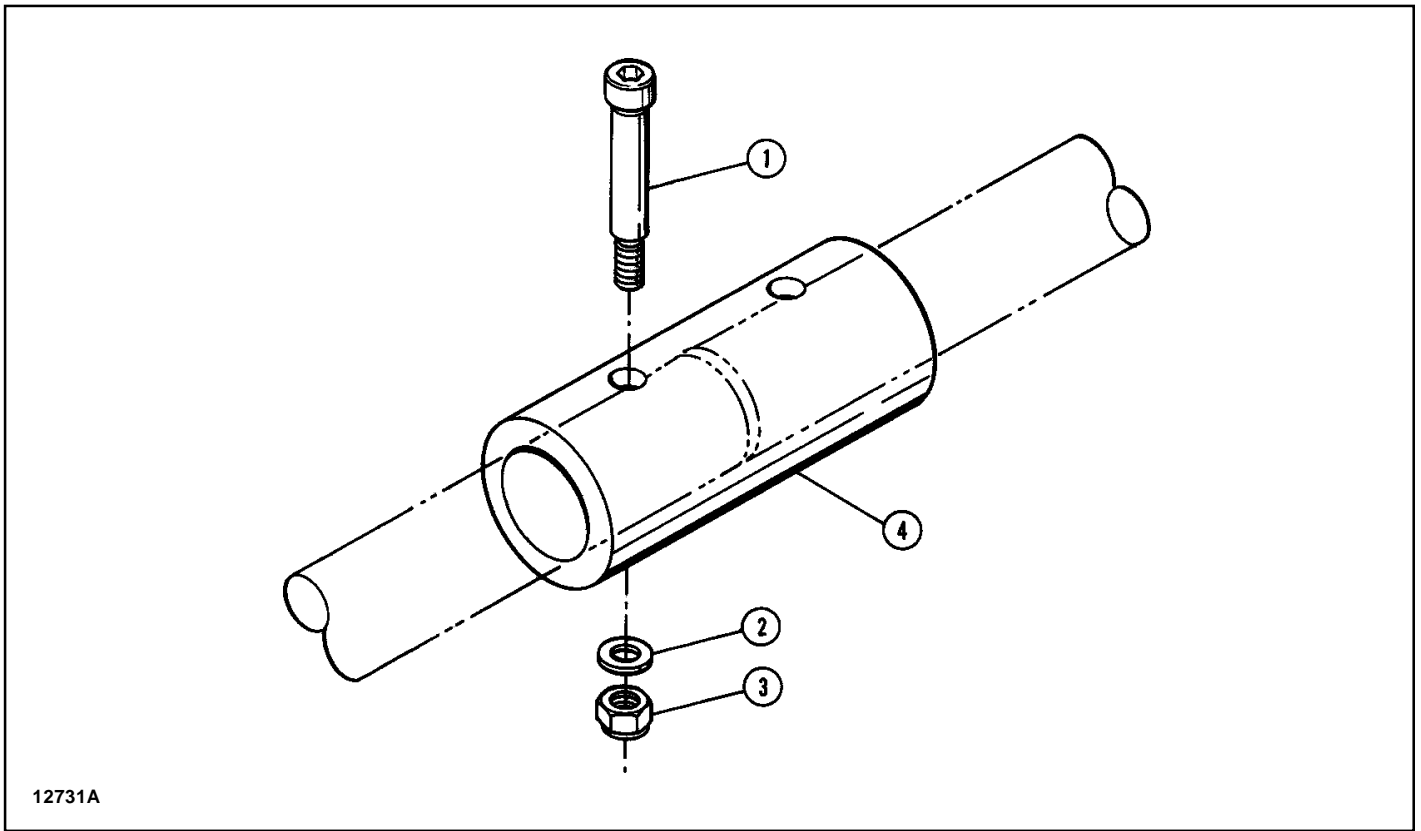
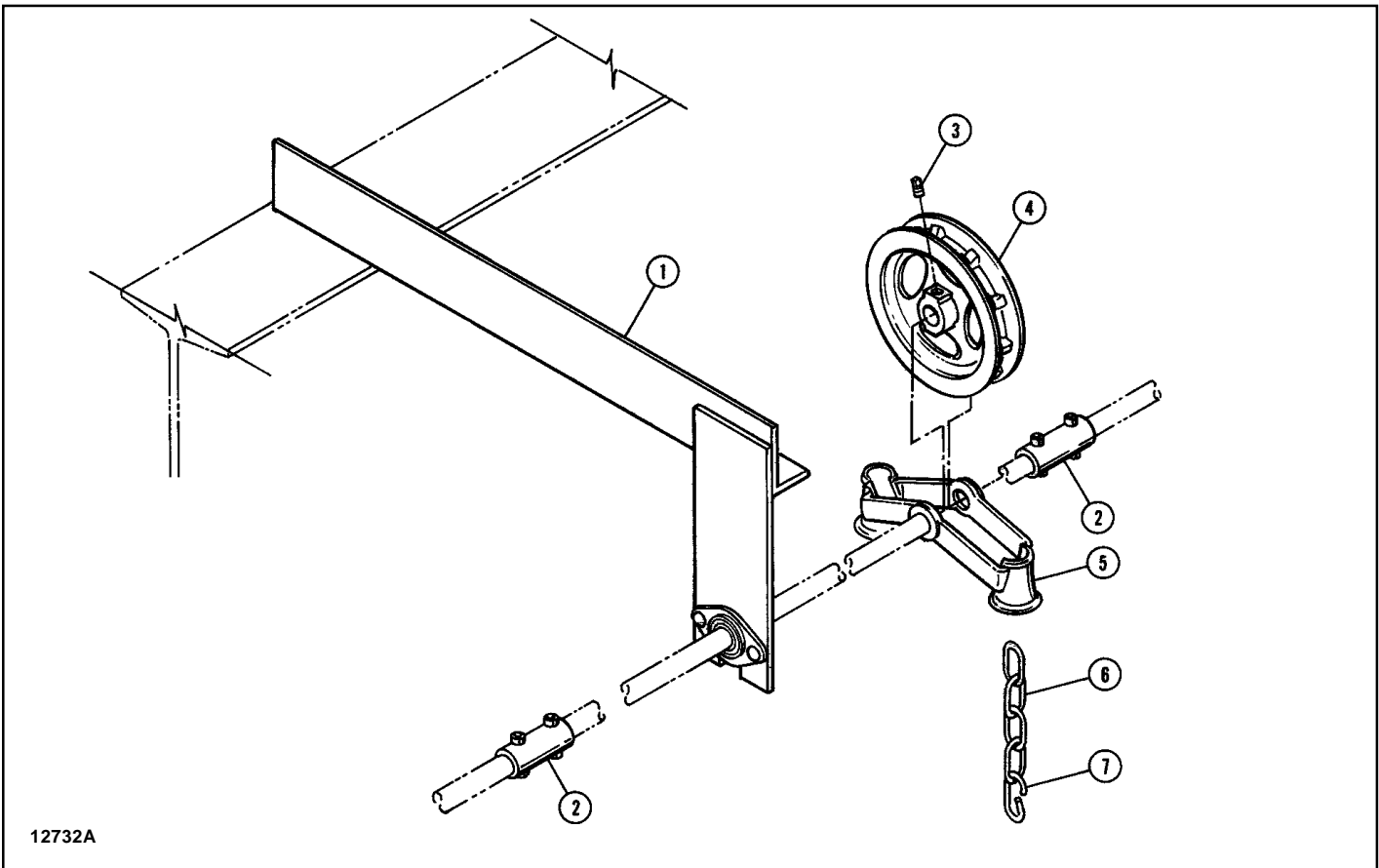

Figure 14. Coupling. Catalog Number 905374.

Ref. No.	Part Number	Description	Qty. Req'd
1	BTK-1001	Socket Head Shoulder Screw	2
2	BTK-1002	Flat Washer	2
3	BTK-1003	Self-Locking Nut	2
4	BTK-1004	Coupling	1

NOTES



12732A

Figure 15. Hand Chain Drive. Catalog Numbers 904539 and 8282.

Ref. No.	Part Number	Description	Qty. Req'd
1		Catalog Number 904539 Consists of Ref. Nos. 1 thru 5:	
2		Catalog Number 904540	1
3	BTK-1101	Catalog Number 905374	2
4	BTK-1102	Square Head Set Screw	1
5	BTK-1103	Hand Chain Wheel	1
		Chain Wheel Guide	1
6	BTK-1104	Catalog Number 8282 Consists of Ref. Nos. 6 and 7:	
7	BTK-1105	Hand Chain	36 ft.
		Connecting Link	1

NOTES

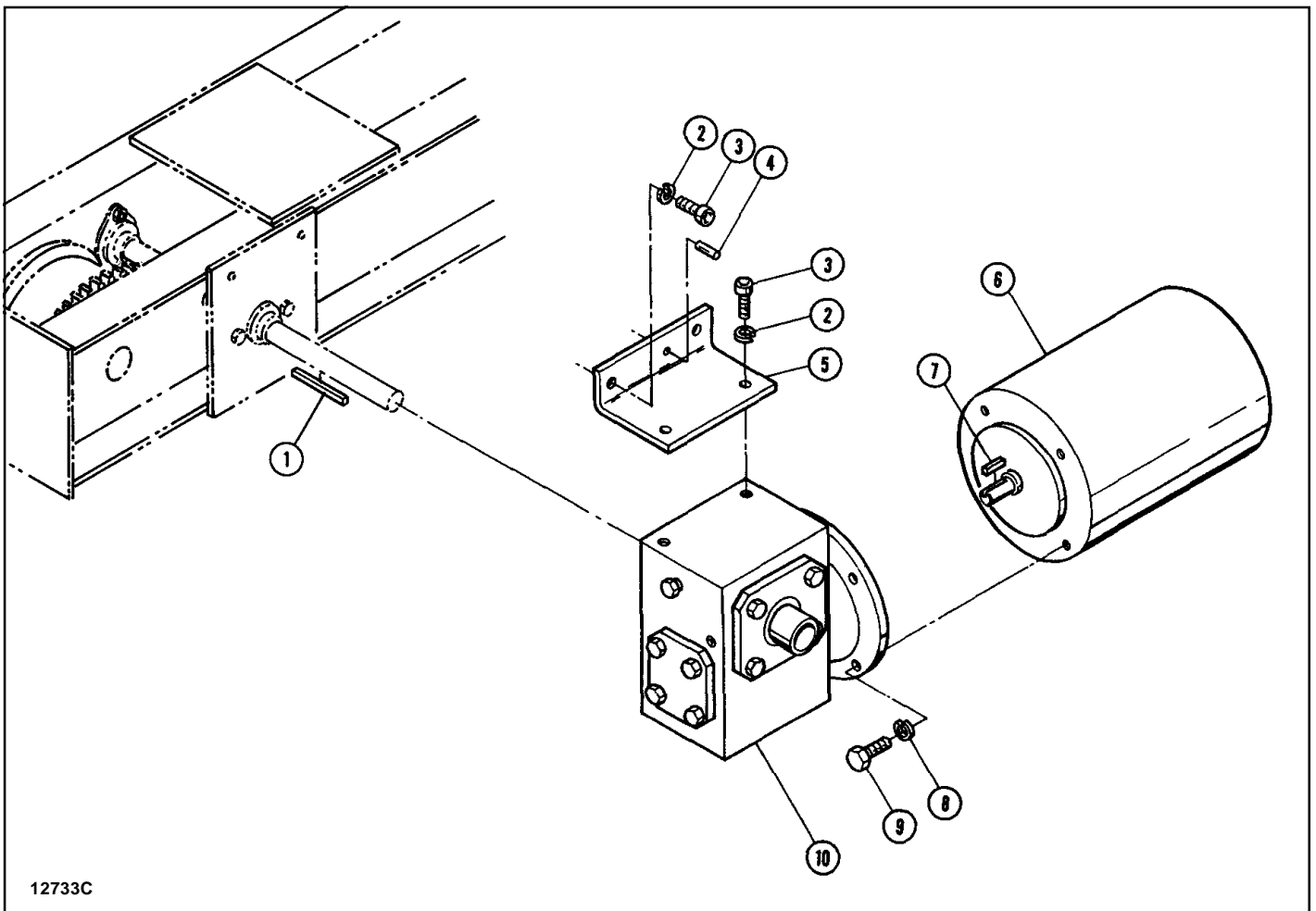

12733C

Figure 16. Gear Reducer (Catalog Numbers 905376 thru 905378) and Motor (Catalog Numbers 905381 and 905382).

Ref. No.	Part Number	Description	Qty. Req'd
1	BTK-1201	Key	1
2	BTK-1202	Spring Lock Washer (5/16)	4
3	BTK-1203	Hex Socket Head Self-Locking Cap Screw (5/16-18 x 1)	4
4	BTK-1204	Grooved Pin (Type A 5/16 x 5/8 Pltd.)	1
5	BTK-1205	Support Plate	1
6		Motor	
		Single Speed	1
	BTK-1241	115/230V - 1 Phase - 60 Hz	
	BTK-1238	200-230/460V - 3 Phase - 60 Hz	
	BTK-1239	575V - 3 Phase - 60 Hz	
		Two Speed	
	BTK-1242	208/230V - 3 Phase - 60 Hz	
	BTK-1243	460V - 3 Phase - 60 Hz	
	BTK-1244	575V - 3 Phase - 60 Hz	
7	BTK-1237	Key	1
8	BTK-1240	Spring Lock Washer (3/8)	4
9	BTK-1245	Hex Head Bolt (3/8-16 x 1)	4
10		Gear Reducer	1
	BTK-1207	10:1 Gear Ratio	
	BTK-1208	15:1 Gear Ratio	
	BTK-1209	20:1 Gear Ratio	

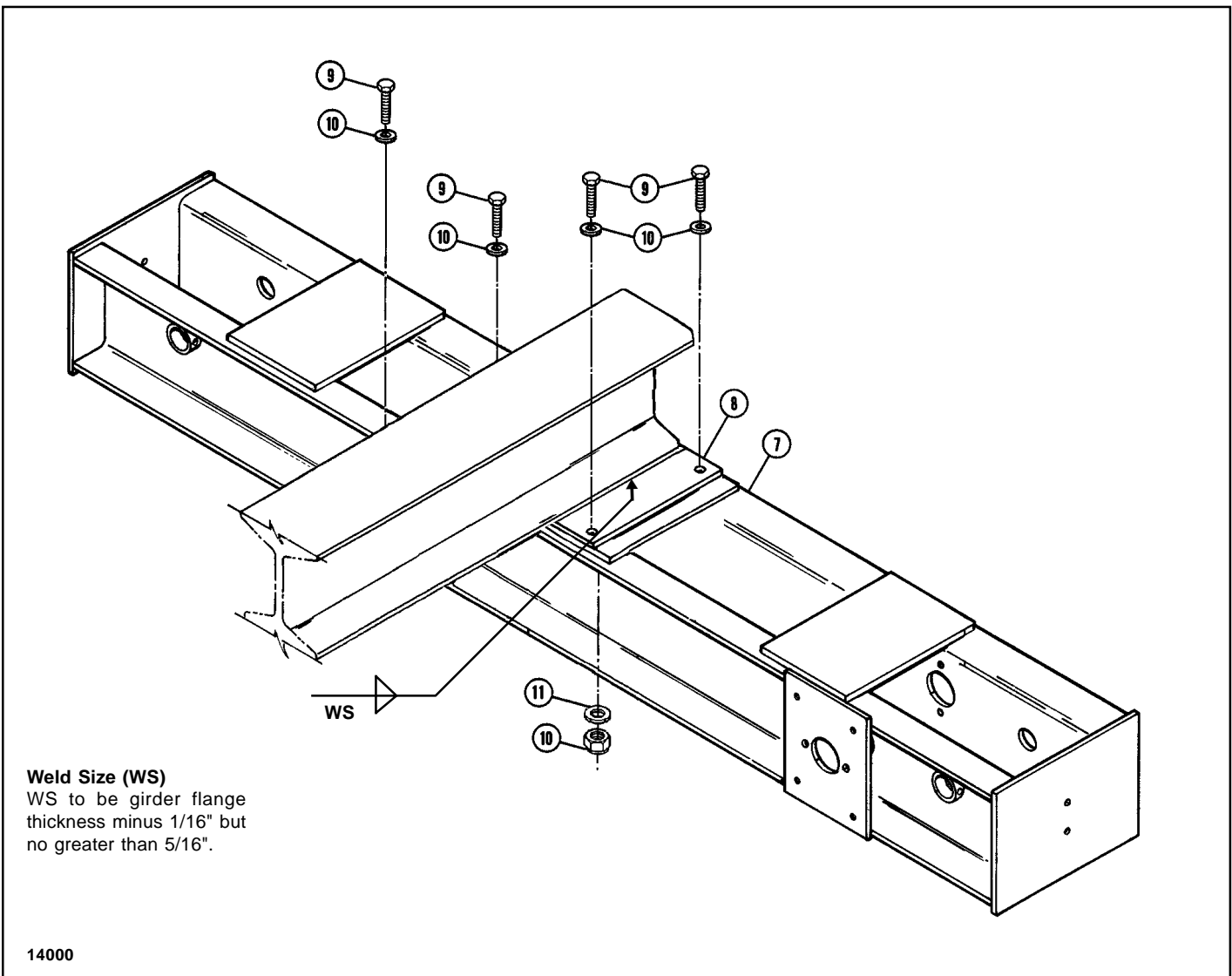

Figure 17. Bolted Uncoped Girder Connection (only 1 connection shown).

Ref. No.	Part Number	Description	Qty. Req'd
7	BTK-2306 BTK-2307	Truck Weldment - 54" or 72" Wheelbase As Shown (Right Hand) Opposite Hand (Left Hand)	1
8	BTK-2308 BTK-2309	Mounting Plate 54" Wheelbase 72" Wheelbase	1
9	BTK-2310	Hex Head Bolt - High Strength	4
10	BTK-2311	Flat Washer	8
11	BTK-2312	Self Locking Nut	4

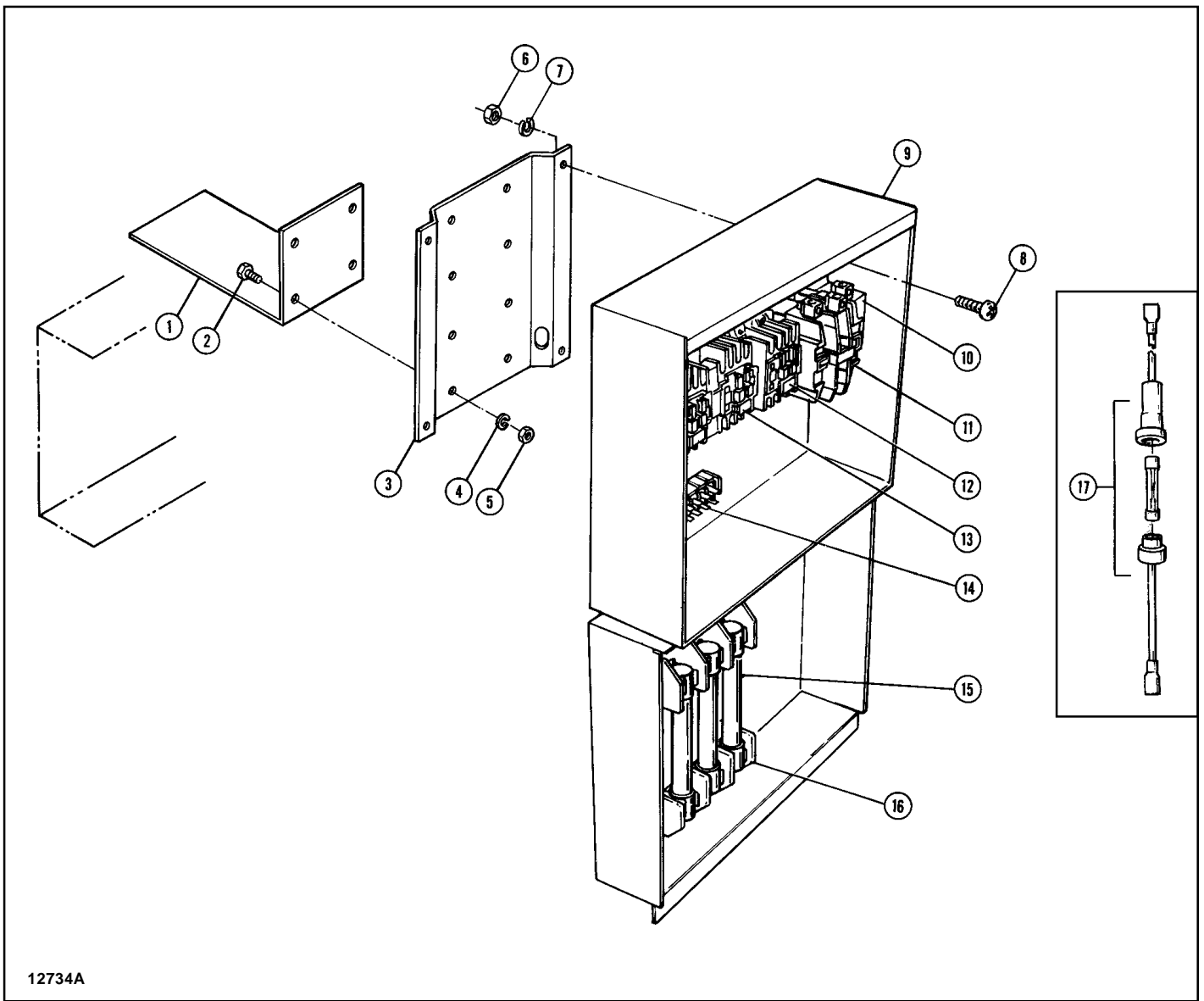

Figure 18. Electrical Enclosure and Mounting. Catalog Numbers 904541 thru 904543.

Ref. No.	Part Number	Description	Qty. Req'd
1	BTK-1351	Connecting Bracket	1
2	BTK-1352	Hex Head Bolt	4
3	BTK-1353	Enclosure Bracket	1
4	BTK-1354	Lockwasher	4
5	BTK-1355	Hex Nut	4
6	BTK-1306	Hex Nut	4
7	BTK-1307	Lockwasher	4
8	BTK-1308	Phillips Screw	4
9	BTK-1309	Electrical Enclosure	1
10	BTK-1310	Transformer 208/24V or 230/24V	1
	BTK-1311	460/24V	
	BTK-1312	575/24V	
	BTK-1313	208/115V or 230/115V	
	BTK-1314	460/115V	
	BTK-1315	575/115V	
11	BTK-1316	Mainline Contactor 24V Control	1
	BTK-1317	115V Control	

Figure 18. Electrical Enclosure and Mounting (Continued).

Ref. No.	Part Number	Description	Qty. Req'd
12		Accelerating Contactor (For 2 Speed Cranes Only)	1
	BTK-1318	24V Control	
	BTK-1319	115V Control	
13		Reversing Contactor	1
	BTK-1320	24V Control	
	BTK-1321	115V Control	
14	BTK-1322	Terminal Board	1
15		Fuses	3
	BTK-1323	3A, 250V	
	BTK-1324	3A, 600V	
16		Fuse Base	1
	BTK-1325	30A, 250V	
	BTK-1326	30A, 600V	
17		Fuse, Fuse Holder and Wire Assembly (Control Circuit)	1
	BTK-1327	3A, 24V	
	BTK-1328	1/2A, 115V	
	*	Fuse Only (Control Circuit)	1
	BTK-1329	3A, 250V Rating	
	BTK-1330	1/2A, 250V Rating	

*Replacement fuses are standard automotive type and may be purchased locally.

NOTES

Recommended Spare Parts for Your Crane Kit

Certain parts of your crane will, in time, require replacement under normal wear conditions. It is suggested that the following parts be purchased for your crane as spares for future use.

1 Set of Wheels
1 Set of Wheel Bearings
1 Set of Fuses

Note: When ordering parts always furnish Model Number of crane kit.

Parts for your crane are available from your authorized repair station.
For the location of your nearest repair station, write:

IN USA

Yale•Lift-Tech
P.O. Box 769
Muskegon, MI 49443-0769

Columbus McKinnon Corporation
140 John James Audubon Parkway
Amherst, NY 14228

Coffing Hoists
P.O. Box 779
Wadesboro, NC 28170

Distributed by Ergonomic Partners
Sales@ErgonomicPartners.com
www.ErgonomicPartners.com
Tel: (314) 884-8884

WARRANTY

WARRANTY AND LIMITATION OF REMEDY AND LIABILITY

A. Seller warrants that its products and parts, when shipped, and its work (including installation, construction and start-up), when performed, will meet applicable specifications, will be of good quality and will be free from defects in material and workmanship. All claims for defective products or parts under this warranty must be made in writing immediately upon discovery and in any event, within one (1) year from shipment of the applicable item unless Seller specifically assumes installation, construction or start-up responsibility. All claims for defective products or parts when Seller specifically assumes installation, construction or start-up responsibility and all claims for defective work must be made in writing immediately upon discovery and in any event, within one (1) year from completion of the applicable work by Seller, provided; however, all claims for defective products and parts made in writing no later than eighteen (18) months after shipment. Defective items must be held for Seller's inspection and returned to the original f.o.b. point upon request. **THE FOREGOING IS EXPRESSLY IN LIEU OF ALL OTHER WARRANTIES WHATSOEVER, EXPRESS, IMPLIED AND STATUTORY, INCLUDING, WITHOUT LIMITATION, THE IMPLIED WARRANTIES OF MERCHANTABILITY AND FITNESS.**

B. Upon Buyer's submission of a claim as provided above and its substantiation, Seller shall at its option either (i) repair or replace its product, part or work at either the original f.o.b. point of delivery or at Seller's authorized service station nearest Buyer or (ii) refund an equitable portion of the purchase price.

C. This warranty is contingent upon Buyer's proper maintenance and care of Seller's products, and does not extend to normal wear and tear. Seller reserves the right to void warranty in event of Buyer's use of inappropriate materials in the course of repair or maintenance, or if Seller's products have been dismantled prior to submission to Seller for warranty inspection.

D. The foregoing is Seller's only obligation and Buyer's exclusive remedy for breach of warranty and is Buyer's exclusive remedy hereunder by way of breach of contract, tort, strict liability or otherwise. In no event shall Buyer be entitled to or Seller liable for incidental or consequential damages. Any action for breach of this agreement must be commenced within one (1) year after the cause of action has accrued.

COLUMBUS MCKINNON CORPORATION